

A
B
C

EXL

SECTION EXL

EXTERIOR LIGHTING SYSTEM

D
E

CONTENTS

XENON TYPE		
BASIC INSPECTION	6	
DIAGNOSIS AND REPAIR WORKFLOW	6	
Work Flow	6	
FUNCTION DIAGNOSIS	9	
HEADLAMP	9	
System Diagram	9	
System Description	9	
Component Parts Location	9	
Component Description	10	
DAYTIME RUNNING LIGHT SYSTEM	11	
System Diagram	11	
System Description	11	
Component Parts Location	11	
Component Description	12	
AUTO LIGHT SYSTEM	13	
System Diagram	13	
System Description	13	
Component Parts Location	14	
Component Description	14	
FRONT FOG LAMP	15	
System Diagram	15	
System Description	15	
Component Parts Location	15	
Component Description	16	
TURN SIGNAL AND HAZARD WARNING LAMPS	17	
System Diagram	17	
System Description	17	
Component Parts Location	17	
Component Description	18	
PARKING, LICENSE PLATE AND TAIL LAMPS	19	
	System Diagram	19
	System Description	19
	Component Parts Location	19
	Component Description	20
	COMBINATION SWITCH READING SYSTEM	21
	System Diagram	21
	System Description	21
	DIAGNOSIS SYSTEM (BCM)	25
	HEADLAMP	25
	HEADLAMP : CONSULT-III Function (BCM-HEAD LAMP)	25
	FLASHER	26
	FLASHER : CONSULT-III Function (BCM-FLASHER)	26
	COMB SW	27
	COMB SW : CONSULT-III Function (BCM-COMB SW)	27
	DIAGNOSIS SYSTEM (IPDM E/R)	29
	Diagnosis Description	29
	CONSULT - III Function (IPDM E/R)	31
	COMPONENT DIAGNOSIS	34
	POWER SUPPLY AND GROUND CIRCUIT	34
	BCM (BODY CONTROL MODULE)	34
	BCM (BODY CONTROL MODULE) : Diagnosis Procedure	34
	BCM (BODY CONTROL MODULE) : Special Repair Requirement	35
	IPDM E/R (INTELLIGENT POWER DISTRIBUTION MODULE ENGINE ROOM)	35
	IPDM E/R (INTELLIGENT POWER DISTRIBUTION MODULE ENGINE ROOM) : Diagnosis Procedure	35

A
B
C
D
E
F
G
H
I
J
K
EXL

HEADLAMP (HI) CIRCUIT	37	Wiring Diagram	122
Description	37	Fail Safe	130
Component Function Check	37	DTC Inspection Priority Chart	132
Diagnosis Procedure	37	DTC Index	134
HEADLAMP (LO) CIRCUIT	39	IPDM E/R (INTELLIGENT POWER DISTRI- BUTION MODULE ENGINE ROOM)	136
Description	39	Reference Value	136
Component Function Check	39	Wiring Diagram	144
Diagnosis Procedure	39	Fail Safe	149
FRONT FOG LAMP CIRCUIT	41	DTC Index	151
Description	41	SYMPTOM DIAGNOSIS	152
Component Function Check	41	EXTERIOR LIGHTING SYSTEM SYMPTOMS	152
Diagnosis Procedure	41	Symptom Table	152
PARKING LAMP CIRCUIT	43	NORMAL OPERATING CONDITION	154
Description	43	Description	154
Component Function Check	43	BOTH SIDE HEADLAMPS DO NOT SWITCH TO HIGH BEAM	155
Diagnosis Procedure	43	Description	155
TURN SIGNAL LAMP CIRCUIT	47	Diagnosis Procedure	155
Description	47	BOTH SIDE HEADLAMPS (LO) ARE NOT TURNED ON	156
Component Function Check	47	Description	156
Diagnosis Procedure	47	Diagnosis Procedure	156
OPTICAL SENSOR	50	PARKING, LICENSE PLATE AND TAIL LAMPS ARE NOT TURNED ON	157
Description	50	Description	157
Component Function Check	50	Diagnosis Procedure	157
Diagnosis Procedure	50	BOTH SIDE FRONT FOG LAMPS ARE NOT TURNED ON	158
HEADLAMP	53	Description	158
Wiring Diagram	53	Diagnosis Procedure	158
DAYTIME RUNNING LIGHT SYSTEM	58	PRECAUTION	159
Wiring Diagram	58	PRECAUTIONS	159
AUTO LIGHT SYSTEM	65	Precaution for Supplemental Restraint System (SRS) "AIR BAG" and "SEAT BELT PRE-TEN- SIONER"	159
Wiring Diagram	65	Precautions For Xenon Headlamp Service	159
FRONT FOG LAMP SYSTEM	71	Precautions Necessary for Steering Wheel Rota- tion after Battery Disconnect (Early Production, With Electronic Steering Column Lock)	160
Wiring Diagram	71	General precautions for service operations	160
TURN SIGNAL AND HAZARD WARNING LAMP SYSTEM	75	ON-VEHICLE MAINTENANCE	161
Wiring Diagram	75	HEADLAMP AIMING ADJUSTMENT	161
PARKING, LICENSE PLATE AND TAIL LAMPS SYSTEM	83	Description	161
Wiring Diagram	83	Aiming Adjustment Procedure	162
STOP LAMP	91	FRONT FOG LAMP AIMING ADJUSTMENT	164
Wiring Diagram	91	Description	164
BACK-UP LAMP	95	Aiming Adjustment Procedure	164
Wiring Diagram	95		
ECU DIAGNOSIS	99		
BCM (BODY CONTROL MODULE)	99		
Reference Value	99		
Terminal Layout	104		
Physical Values	104		

ON-VEHICLE REPAIR	165	Component Parts Location	185	
		Component Description	186	A
FRONT COMBINATION LAMP	165	AUTO LIGHT SYSTEM	187	
Exploded View	165	System Diagram	187	B
Removal and Installation	165	System Description	187	
Replacement	166	Component Parts Location	188	C
Disassembly and Assembly	166	Component Description	188	
FRONT FOG LAMP	168	FRONT FOG LAMP	189	
Exploded View	168	System Diagram	189	D
Removal and Installation	168	System Description	189	
Replacement	168	Component Parts Location	189	E
OPTICAL SENSOR	170	Component Description	190	
Exploded View	170	TURN SIGNAL AND HAZARD WARNING		
Removal and Installation	170	LAMPS	191	
LIGHTING & TURN SIGNAL SWITCH	171	System Diagram	191	F
Removal and Installation	171	System Description	191	
HAZARD SWITCH	172	Component Parts Location	191	G
Exploded View	172	Component Description	192	
Removal and Installation	172	PARKING, LICENSE PLATE AND TAIL		
REAR COMBINATION LAMP	173	LAMPS	193	
Exploded View	173	System Diagram	193	H
Removal and Installation	173	System Description	193	
Replacement	174	Component Parts Location	193	I
HIGH-MOUNTED STOP LAMP	175	Component Description	194	
Exploded View	175	COMBINATION SWITCH READING SYSTEM		
Removal and Installation	175		195	
LICENSE PLATE LAMP	177	System Diagram	195	J
Exploded View	177	System Description	195	
Removal and Installation	177	DIAGNOSIS SYSTEM (BCM)	199	
Replacement	177	HEADLAMP	199	K
SERVICE DATA AND SPECIFICATIONS		HEADLAMP : CONSULT-III Function (BCM-		
(SDS)	179	HEAD LAMP)	199	
SERVICE DATA AND SPECIFICATIONS		FLASHER	200	EXL
(SDS)	179	FLASHER : CONSULT-III Function (BCM-		
Bulb Specifications	179	FLASHER)	200	M
HALOGEN TYPE		COMB SW	201	
BASIC INSPECTION	180	COMB SW : CONSULT-III Function (BCM-COMB		
DIAGNOSIS AND REPAIR WORKFLOW	180	SW)	201	N
Work Flow	180	DIAGNOSIS SYSTEM (IPDM E/R)	203	
FUNCTION DIAGNOSIS	183	Diagnosis Description	203	O
HEADLAMP	183	CONSULT - III Function (IPDM E/R)	205	
System Diagram	183	COMPONENT DIAGNOSIS	208	
System Description	183	POWER SUPPLY AND GROUND CIRCUIT ..	208	P
Component Parts Location	183	BCM (BODY CONTROL MODULE)	208	
Component Description	184	BCM (BODY CONTROL MODULE) : Diagnosis		
DAYTIME RUNNING LIGHT SYSTEM	185	Procedure	208	
System Diagram	185	BCM (BODY CONTROL MODULE) : Special Re-		
System Description	185	pair Requirement	209	

IPDM E/R (INTELLIGENT POWER DISTRIBUTION MODULE ENGINE ROOM)	209	ECU DIAGNOSIS	273
IPDM E/R (INTELLIGENT POWER DISTRIBUTION MODULE ENGINE ROOM) : Diagnosis Procedure	209	BCM (BODY CONTROL MODULE)	273
HEADLAMP (HI) CIRCUIT	211	Reference Value	273
Description	211	Terminal Layout	278
Component Function Check	211	Physical Values	278
Diagnosis Procedure	211	Wiring Diagram	296
HEADLAMP (LO) CIRCUIT	213	Fail Safe	304
Description	213	DTC Inspection Priority Chart	306
Component Function Check	213	DTC Index	308
Diagnosis Procedure	213	IPDM E/R (INTELLIGENT POWER DISTRIBUTION MODULE ENGINE ROOM)	310
FRONT FOG LAMP CIRCUIT	215	Reference Value	310
Description	215	Wiring Diagram	318
Component Function Check	215	Fail Safe	323
Diagnosis Procedure	215	DTC Index	325
PARKING LAMP CIRCUIT	217	SYMPTOM DIAGNOSIS	326
Description	217	EXTERIOR LIGHTING SYSTEM SYMPTOMS	326
Component Function Check	217	Symptom Table	326
Diagnosis Procedure	217	NORMAL OPERATING CONDITION	328
TURN SIGNAL LAMP CIRCUIT	221	Description	328
Description	221	BOTH SIDE HEADLAMPS DO NOT SWITCH TO HIGH BEAM	329
Component Function Check	221	Description	329
Diagnosis Procedure	221	Diagnosis Procedure	329
OPTICAL SENSOR	224	BOTH SIDE HEADLAMPS (LO) ARE NOT TURNED ON	330
Description	224	Description	330
Component Function Check	224	Diagnosis Procedure	330
Diagnosis Procedure	224	PARKING, LICENSE PLATE AND TAIL LAMPS ARE NOT TURNED ON	331
HEADLAMP	227	Description	331
Wiring Diagram	227	Diagnosis Procedure	331
DAYTIME RUNNING LIGHT SYSTEM	232	BOTH SIDE FRONT FOG LAMPS ARE NOT TURNED ON	332
Wiring Diagram	232	Description	332
AUTO LIGHT SYSTEM	239	Diagnosis Procedure	332
Wiring Diagram	239	PRECAUTION	333
FRONT FOG LAMP SYSTEM	245	PRECAUTIONS	333
Wiring Diagram	245	Precaution for Supplemental Restraint System (SRS) "AIR BAG" and "SEAT BELT PRE-TENSIONER"	333
TURN SIGNAL AND HAZARD WARNING LAMP SYSTEM	249	Precautions Necessary for Steering Wheel Rotation after Battery Disconnect (Early Production, With Electronic Steering Column Lock)	333
Wiring Diagram	249	General precautions for service operations	334
PARKING, LICENSE PLATE AND TAIL LAMPS SYSTEM	257	ON-VEHICLE MAINTENANCE	335
Wiring Diagram	257	HEADLAMP AIMING ADJUSTMENT	335
STOP LAMP	265	Description	335
Wiring Diagram	265		
BACK-UP LAMP	269		
Wiring Diagram	269		

Aiming Adjustment Procedure	336	HAZARD SWITCH	345	
FRONT FOG LAMP AIMING ADJUSTMENT ..	338	Exploded View	345	A
Description	338	Removal and Installation	345	
Aiming Adjustment Procedure	338	REAR COMBINATION LAMP	346	B
ON-VEHICLE REPAIR	339	Exploded View	346	
FRONT COMBINATION LAMP	339	Removal and Installation	346	C
Exploded View	339	Replacement	347	
Removal and Installation	339	HIGH-MOUNTED STOP LAMP	348	D
Replacement	340	Exploded View	348	
Disassembly and Assembly	340	Removal and Installation	348	E
FRONT FOG LAMP	341	LICENSE PLATE LAMP	350	
Exploded View	341	Exploded View	350	F
Removal and Installation	341	Removal and Installation	350	
Replacement	341	Replacement	350	G
OPTICAL SENSOR	343	SERVICE DATA AND SPECIFICATIONS		
Exploded View	343	(SDS)	352	
Removal and Installation	343	SERVICE DATA AND SPECIFICATIONS		
LIGHTING & TURN SIGNAL SWITCH	344	(SDS)	352	
Removal and Installation	344	Bulb Specifications	352	H
				I
				J
				K
				EXL
				M
				N
				O
				P

BASIC INSPECTION

DIAGNOSIS AND REPAIR WORKFLOW

Work Flow

INFOID:000000005460818

OVERALL SEQUENCE

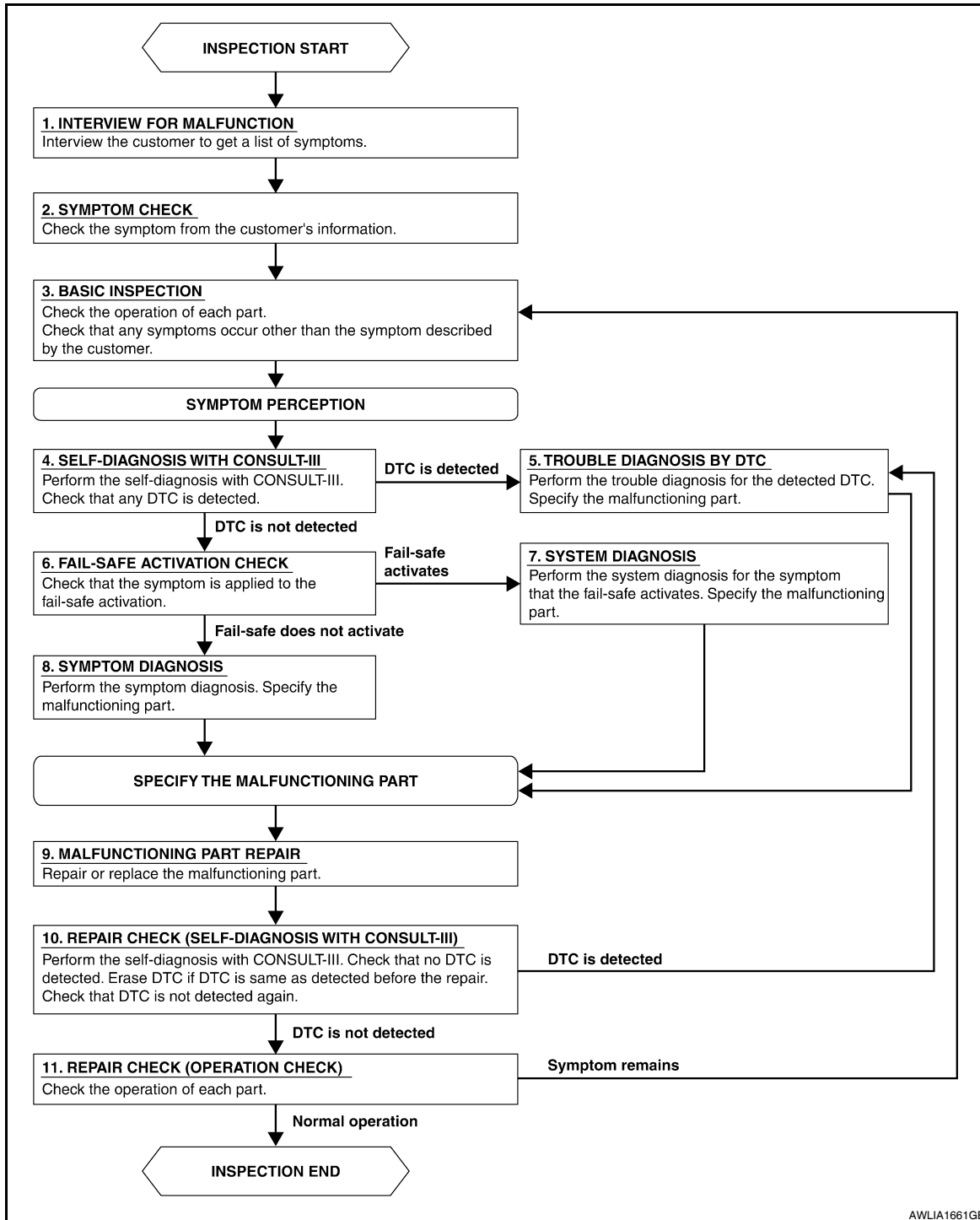

DETAILED FLOW

1. INTERVIEW FOR MALFUNCTION

Find out what the customer's concerns are.

DIAGNOSIS AND REPAIR WORKFLOW

[XENON TYPE]

< BASIC INSPECTION >

>> GO TO 2.

2. SYMPTOM CHECK

Verify the symptom from the customer's information.

>> GO TO 3.

3. BASIC INSPECTION

Check the operation of each part. Check if any concerns occur other than those mentioned in the customer interview.

>> GO TO 4.

4. SELF-DIAGNOSIS WITH CONSULT-III

Perform the self diagnosis with CONSULT-III. Check if any DTC is detected.

Is any DTC detected?

YES >> GO TO 5.

NO >> GO TO 6.

5. TROUBLE DIAGNOSIS BY DTC

Perform the trouble diagnosis for the detected DTC. Specify the malfunctioning part.

>> GO TO 9.

6. FAIL-SAFE ACTIVATION CHECK

Determine if the customer's concern is related to fail-safe activation.

Does the fail-safe activate?

YES >> GO TO 7.

NO >> GO TO 8.

7. SYSTEM DIAGNOSIS

Perform the system diagnosis for the system in which the fail-safe activates. Specify the malfunctioning part.

>> GO TO 9.

8. SYMPTOM DIAGNOSIS

Perform the symptom diagnosis. Specify the malfunctioning part.

>> GO TO 9.

9. MALFUNCTION PART REPAIR

Repair or replace the malfunctioning part.

>> GO TO 10.

10. REPAIR CHECK (SELF-DIAGNOSIS WITH CONSULT-III)

Perform the self diagnosis with CONSULT-III. Verify that no DTCs are detected. Erase all DTCs which were detected prior to the repair. Perform the self diagnosis with CONSULT-III again. Verify that DTC is not detected again.

Is any DTC detected?

YES >> GO TO 5.

NO >> GO TO 11.

11. REPAIR CHECK (OPERATION CHECK)

Check the operation of each part.

A

B

C

D

E

F

G

H

I

J

K

EXL

M

N

O

P

DIAGNOSIS AND REPAIR WORKFLOW

< BASIC INSPECTION >

[XENON TYPE]

Does it operate normally?

YES >> Inspection End.

NO >> GO TO 3.

FUNCTION DIAGNOSIS

HEADLAMP

System Diagram

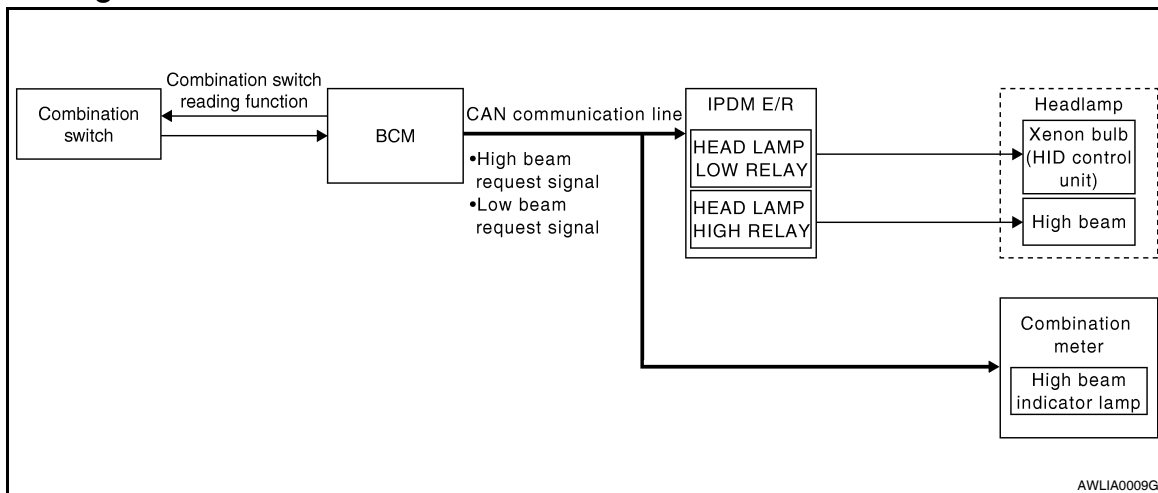

System Description

INFOID:000000005460820

Control of the headlamp system is dependent upon the position of the lighting switch (combination switch). When the lighting switch is placed in the 2nd position, the BCM (body control module) receives input requesting the headlamps and park lamps to illuminate. This input is communicated to the IPDM E/R (intelligent power distribution module engine room) across the CAN communication lines. The CPU (central processing unit) of the IPDM E/R controls the headlamp high and headlamp low relay coils. When energized, these relays direct power to the respective headlamps, which then illuminate.

Component Parts Location

INFOID:000000005460821

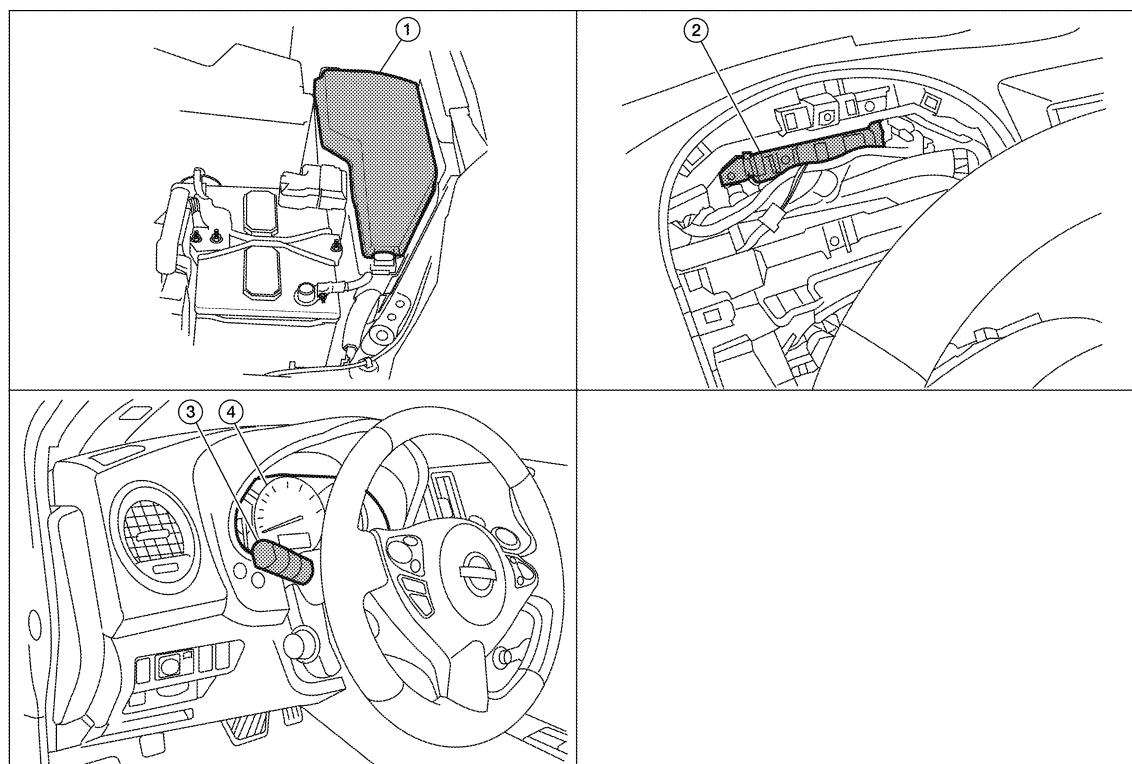

AWLIA1631ZZ

EXL

HEADLAMP

< FUNCTION DIAGNOSIS >

[XENON TYPE]

1. IPDM E/R E17, E18, E200
2. BCM M16, M17, M18, M19 (view with combination meter removed)
3. Combination Switch (lighting and turn signal switch) M28
4. Combination Meter M24

Component Description

INFOID:000000005460822

XENON HEADLAMP

A Xenon type headlamp is adapted to the low beam headlamps. Xenon bulbs do not use a filament. Instead, they produce light when a high voltage current is passed between two tungsten electrodes through a mixture of Xenon (an inert gas) and certain other metal halides. In addition to added lighting power, electronic control of the power supply gives the headlamps stable quality and tone color.

Following are some of the many advantages of the Xenon-type headlamp.

- The light produced by the headlamps is a white color comparable to sunlight that is easy on the eyes.
- Light output is nearly double that of halogen headlamps, affording increased area of illumination.
- The light features a high relative spectral distribution at wavelengths to which the human eye is most sensitive. This means that even in the rain, more light is reflected back from the road surface toward the vehicle for added visibility.
- Power consumption is approximately 25 percent less than halogen headlamps, reducing battery load.

HIGH BEAM OPERATION/FLASH-TO-PASS OPERATION

With the lighting switch in the 2ND position and placed in HIGH position, the BCM receives input requesting the headlamp high beams to illuminate. The flash-to-pass feature can be used any time and also sends a signal to the BCM. This input is communicated to the IPDM E/R across the CAN communication lines. The CPU of the combination meter controls the ON/OFF status of the HIGH BEAM indicator. The CPU of the IPDM E/R controls the headlamp high relay coil which directs power to the high beam headlamps.

EXTERIOR LAMP BATTERY SAVER CONTROL

With the lighting switch (combination switch) in the 2nd position and the ignition switch is turned from ON or ACC to OFF, the battery saver feature is activated.

Under this condition, the headlamps remain illuminated for 5 minutes unless the lighting switch position is changed. If the lighting switch position is changed, then the headlamps are turned off.

This setting can be changed by CONSULT-III. Refer to [EXL-25. "HEADLAMP : CONSULT-III Function \(BCM-HEAD LAMP\)".](#)

DAYTIME RUNNING LIGHT SYSTEM

< FUNCTION DIAGNOSIS >

[XENON TYPE]

DAYTIME RUNNING LIGHT SYSTEM

System Diagram

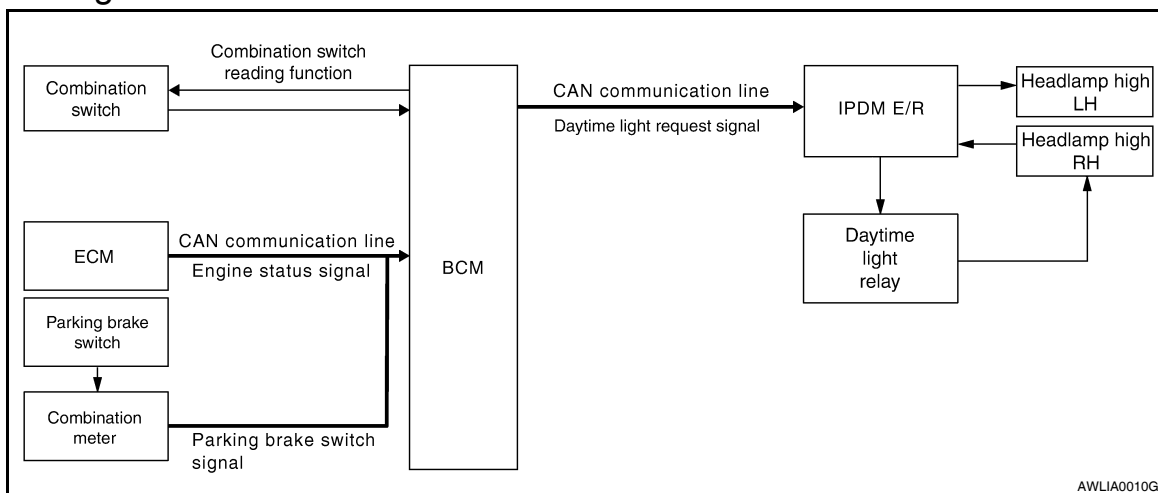

System Description

INFOID:000000005460824

The headlamp system for Canada vehicles is equipped with a daytime light relay that activates the high beam headlamps at approximately half illumination whenever the engine is running. If the parking brake is depressed before the engine is started, the daytime lights will not be illuminated. The daytime lights will illuminate once the parking brake is released. Thereafter, the daytime lights will continue to operate when the parking brake is depressed.

Component Parts Location

INFOID:000000005460825

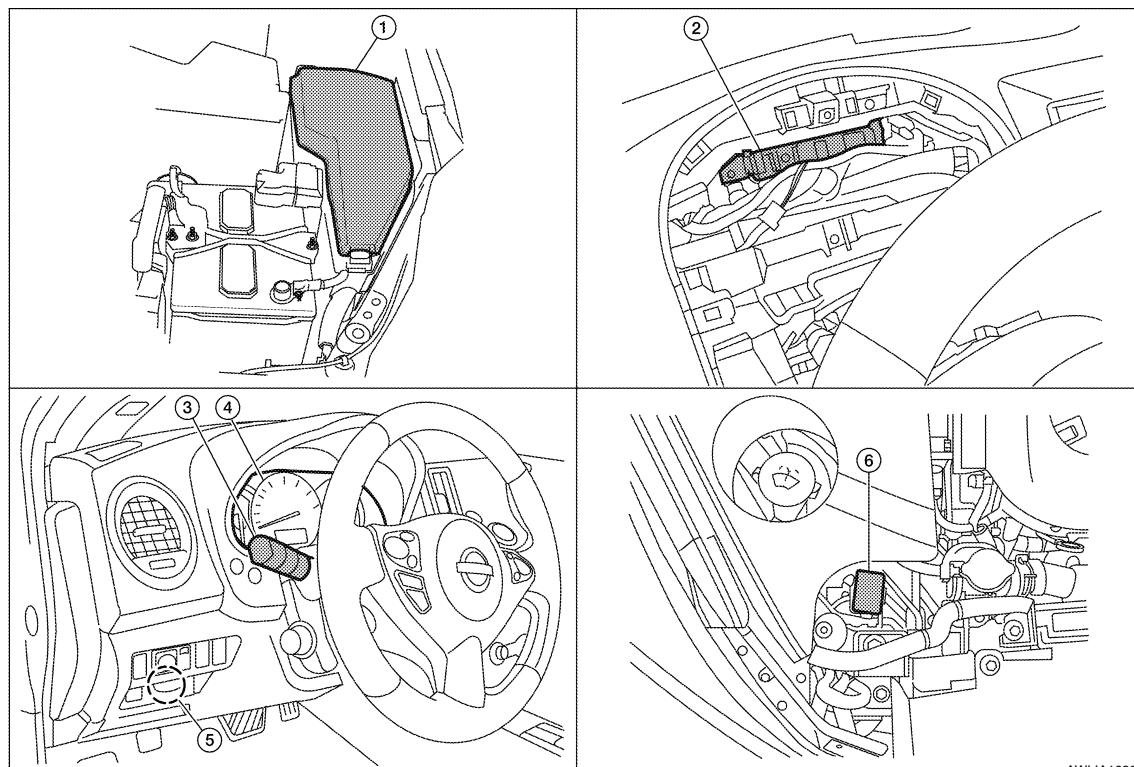

- | | | |
|----------------------------------|---|---|
| 1. IPDM E/R E17, E18, E200, E201 | 2. BCM M16, M17, M18, M19 (view with combination meter removed) | 3. Combination switch (lighting and turn signal switch) M28 |
| 4. Combination meter M24 | 5. Parking brake switch E35 | 6. Daytime light relay E228 |

DAYTIME RUNNING LIGHT SYSTEM

< FUNCTION DIAGNOSIS >

[XENON TYPE]

Component Description

INFOID:000000005460826

After starting the engine with the parking brake released and the lighting switch in the OFF or 1ST position, the headlamp high beam automatically turns on. With the lighting switch in the 2nd position or with autolamps ON, the headlamps function the same as conventional light systems.

OPERATION

The BCM monitors inputs from the parking brake switch and the combination switch to determine when to activate the daytime light system. The BCM sends a daytime light request to the IPDM E/R via the CAN communication lines. The IPDM E/R grounds the daytime light relay which in turn, provides power to the ground side of the RH high beam lamp. Power flows backward through the RH high beam lamp to the IPDM E/R, through the high beam fuses, through the LH high beam lamp circuit to the LH high beam lamp and on to ground. The high beam lamps are wired in series which causes them to illuminate at a reduced intensity.

Engine		With engine stopped									With engine running								
Lighting switch		OFF			1ST			2ND			OFF			1ST			2ND		
		Hi	Lo	P	Hi	Lo	P	Hi	Lo	P	Hi	Lo	P	Hi	Lo	P	Hi	Lo	P
Headlamp	High beam	-	-	-	-	-	×	×	-	×	●*	●*	×	●*	●*	×	×	-	×
	Low beam	-	-	-	-	-	×	×	×	×	-	-	×	-	-	×	×	×	×
Tail lamp		-	-	-	×	×	×	×	×	×	-	-	-	×	×	×	×	×	×
License and instrument illumination lamp		-	-	-	×	×	×	×	×	×	-	-	-	×	×	×	×	×	×

- Hi: "HIGH BEAM" position
- Lo: "LOW BEAM" position
- P: "FLASH TO PASS" position
- ×: Lamp "ON"
- -: Lamp "OFF"
- ●: Lamp dims. (Added functions)
- *: When starting the engine with the parking brake released, the daytime lights will operate.
When starting the engine with the parking brake depressed, the daytime lights will not operate.

AUTO LIGHT SYSTEM

System Diagram

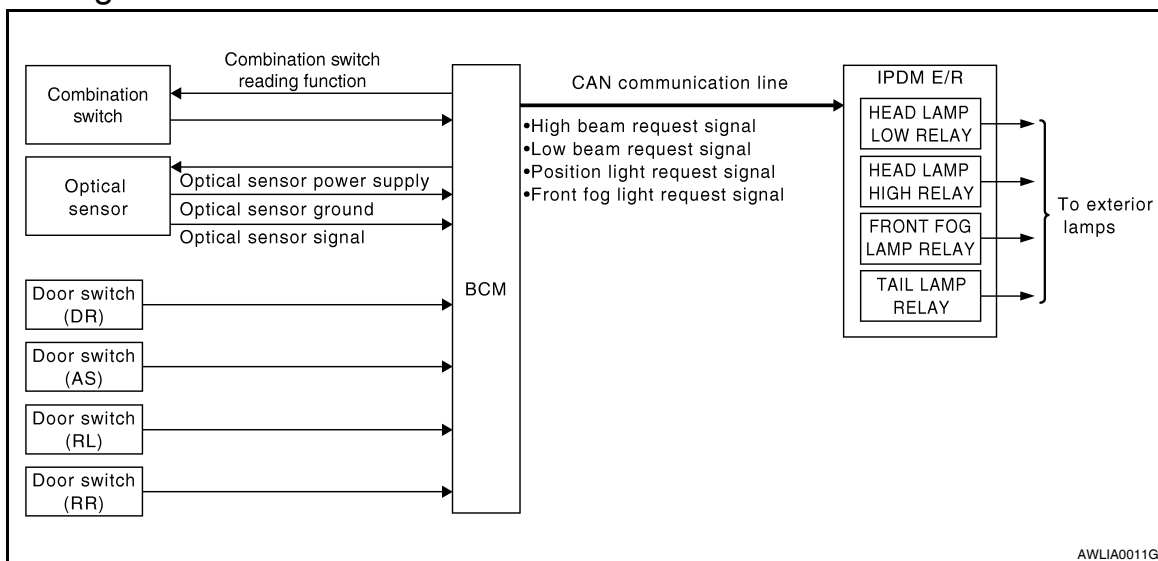

System Description

INFOID:000000005460828

- BCM (Body Control Module) controls auto light operation according to signals from optical sensor, lighting switch and ignition switch.
- IPDM E/R (Intelligent Power Distribution Module Engine Room) operates parking, license plate, tail, front fog lamps and headlamps according to CAN communication signals from BCM.
- Optical sensor detects ambient brightness of 800 to 2,500 lux, converts light (lux) to voltage, and then sends the optical sensor signal to BCM.

OUTLINE

The auto light control system has an optical sensor that detects outside brightness. When the lighting switch is in AUTO position, it automatically turns ON/OFF the parking, license plate, tail, front fog lamps and headlamps in accordance with the ambient light. Sensitivity can be adjusted in four steps. For the details of the setting, refer to [EXL-25, "HEADLAMP : CONSULT-III Function \(BCM-HEAD LAMP\)"](#).

EXL

AUTO LIGHT SYSTEM

< FUNCTION DIAGNOSIS >

[XENON TYPE]

Component Parts Location

INFOID:000000005460829

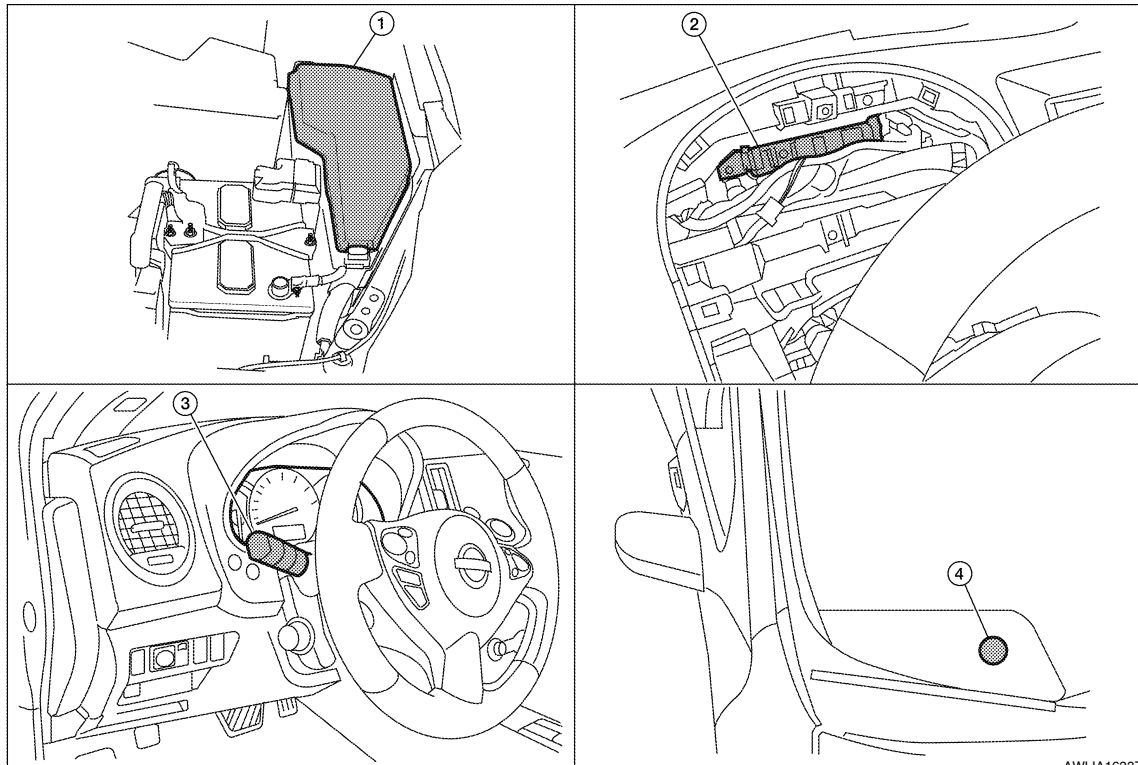

1. IPDM E/R E17, E18, E20
2. BCM M16, M17, M18, M19, M21 (view with combination meter removed)
3. Combination switch (lighting and turn signal switch) M28
4. Optical sensor M66

Component Description

INFOID:000000005460830

AUTO LIGHT OPERATION

Applicable lamps

- Low beam headlamp
- Parking, license plate and tail lamps
- High beam headlamp (with the lighting switch in HIGH BEAM position)
- Front fog lamp (with the lighting switch in front fog lamp ON position)

When the lighting switch is in AUTO position with the ignition switch in ON position, BCM detects the AUTO LIGHT (ON) by BCM combination switch reading function. BCM turns automatically ON/OFF the applicable lamps according to ambient brightness.

NOTE:

Timing for when lamps turn ON/OFF can be changed by the function setting of CONSULT-III. Refer to [EXL-25, "HEADLAMP : CONSULT-III Function \(BCM-HEAD LAMP\)"](#).

FRONT FOG LAMP

< FUNCTION DIAGNOSIS >

[XENON TYPE]

FRONT FOG LAMP

System Diagram

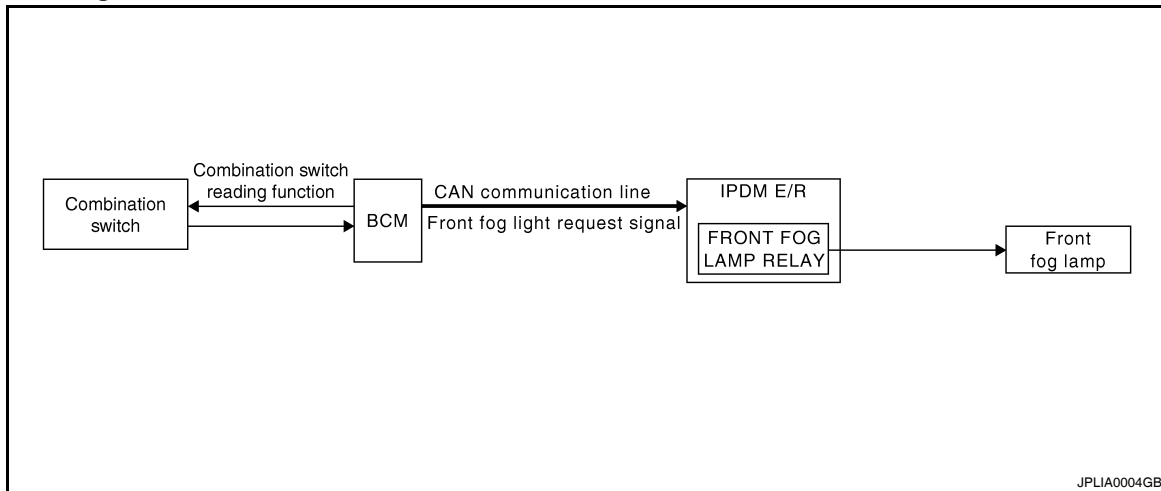

System Description

INFOID:000000005460832

- BCM (Body Control Module) controls front fog lamp operation.
- IPDM E/R (Intelligent Power Distribution Module Engine Room) operates front fog lamp according to CAN communication signals from BCM.
- Combination meter operates front fog lamp indicator according to inputs via the CAN communication lines.

Component Parts Location

INFOID:000000005460833

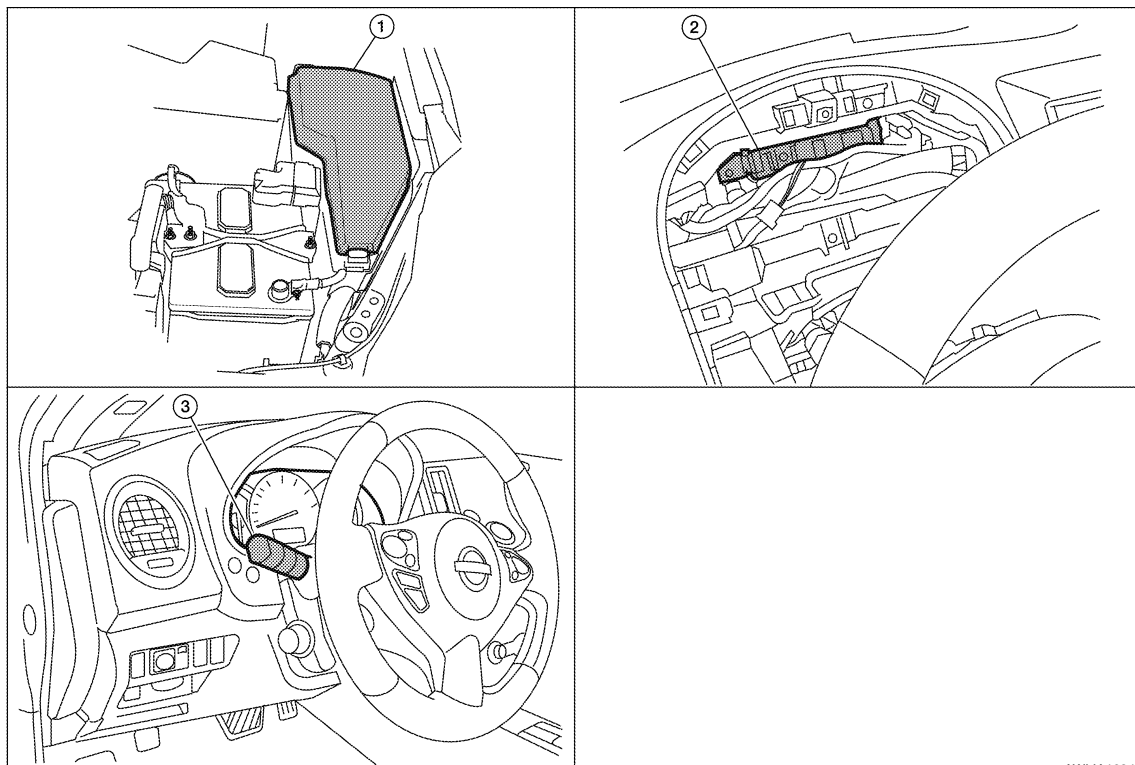

FRONT FOG LAMP

< FUNCTION DIAGNOSIS >

[XENON TYPE]

Component Description

INFOID:000000005460834

FRONT FOG LAMP OPERATION

When the lighting switch is in front fog lamp ON position and also in 1ST or 2ND position or AUTO position (headlamp is ON), the BCM detects FR FOG ON and the HEAD LAMP1, 2 ON or the AUTO LIGHT ON. The BCM sends a front fog lamp request ON signal through the CAN communication lines to the IPDM E/R. The IPDM E/R then turns ON the front fog lamp relay sending power to the front fog lamps.

The combination meter also receives a front fog lamp request ON signal through the CAN communication lines at which time it turns the front fog indicator ON.

TURN SIGNAL AND HAZARD WARNING LAMPS

< FUNCTION DIAGNOSIS >

[XENON TYPE]

TURN SIGNAL AND HAZARD WARNING LAMPS

System Diagram

INFOID:000000005460835

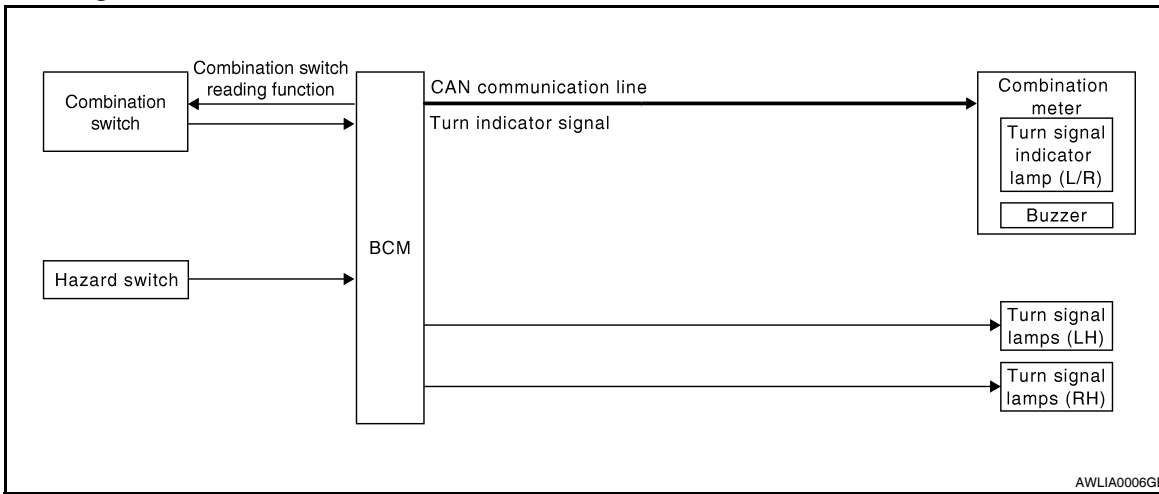

System Description

INFOID:000000005460836

- BCM (Body Control Module) controls turn signal lamp (RH and LH) and hazard warning lamp operation.
- Combination meter operates turn signal indicator (RH and LH) according to CAN communication signals from BCM.

Component Parts Location

INFOID:000000005460837

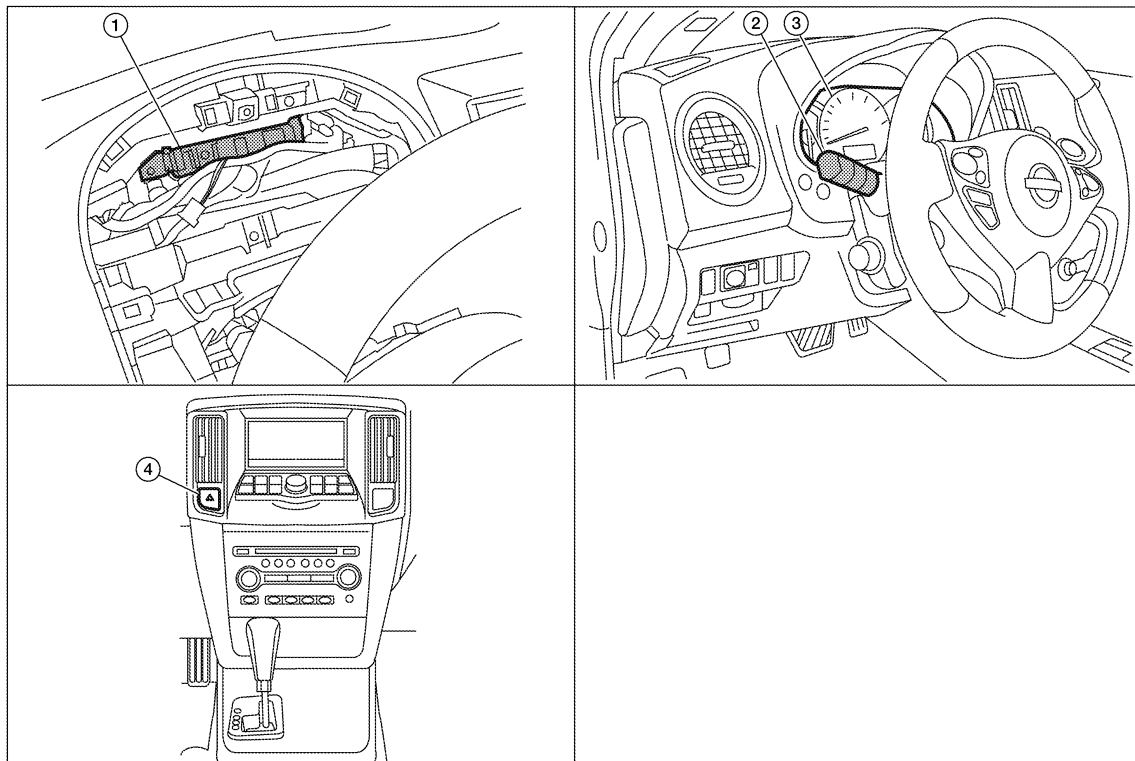

1. BCM M16, M17, M18, M19 (view with combination meter removed)
2. Combination switch (lighting and turn signal switch) M28
3. Combination meter M24
4. Hazard switch M54

TURN SIGNAL AND HAZARD WARNING LAMPS

< FUNCTION DIAGNOSIS >

[XENON TYPE]

Component Description

INFOID:000000005460838

TURN SIGNAL OPERATION

When the turn signal switch is in LH or RH position with the ignition switch in ON position, the BCM detects the TURN RH or TURN LH ON request. The BCM outputs the flasher output signal to the respective turn signal lamp. The BCM sends a turn signal indicator ON request through the CAN communication lines to the combination meter. The combination meter then activates the appropriate turn signal indicator and audible buzzer.

HAZARD LAMP OPERATION

When the hazard switch is in ON position, the BCM detects the hazard switch signal ON. The BCM outputs the flasher output signal (right and left). The BCM sends a hazard indicator signal ON request through the CAN communication lines to the combination meter. The combination meter then activates the hazard indicator and audible buzzer.

REMOTE KEYLESS ENTRY OPERATION

The remote keyless entry receiver transmits Intelligent Key signal to BCM, then BCM controls hazard lamps. Refer to [SEC-21, "System Description"](#).

PARKING, LICENSE PLATE AND TAIL LAMPS

< FUNCTION DIAGNOSIS >

[XENON TYPE]

PARKING, LICENSE PLATE AND TAIL LAMPS

System Diagram

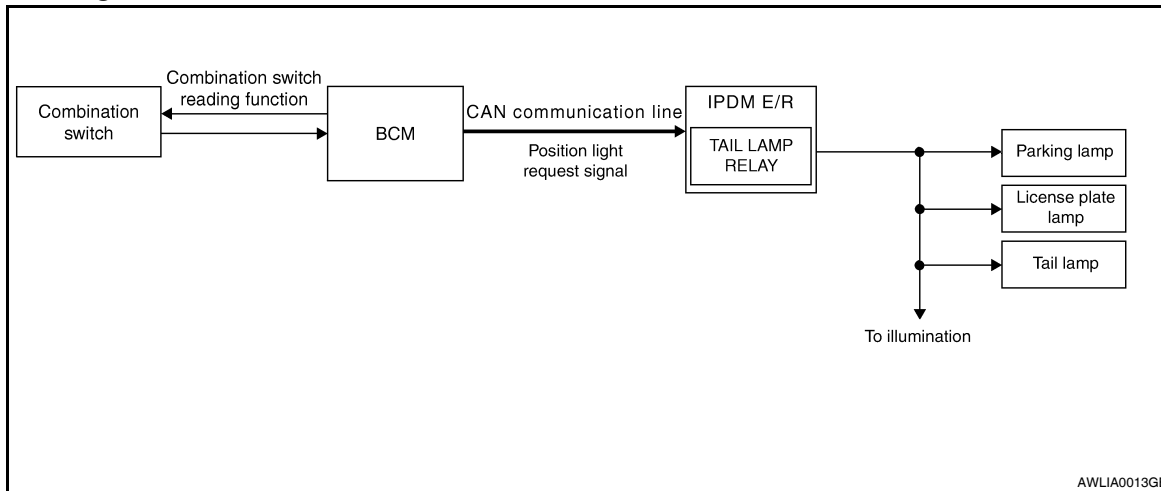

System Description

INFOID:000000005460840

- BCM (Body Control Module) controls parking, license plate and tail lamps operation.
- IPDM E/R (Intelligent Power Distribution Module Engine Room) operates parking, license plate and tail lamps according to CAN communication signals from BCM.

Component Parts Location

INFOID:000000005460841

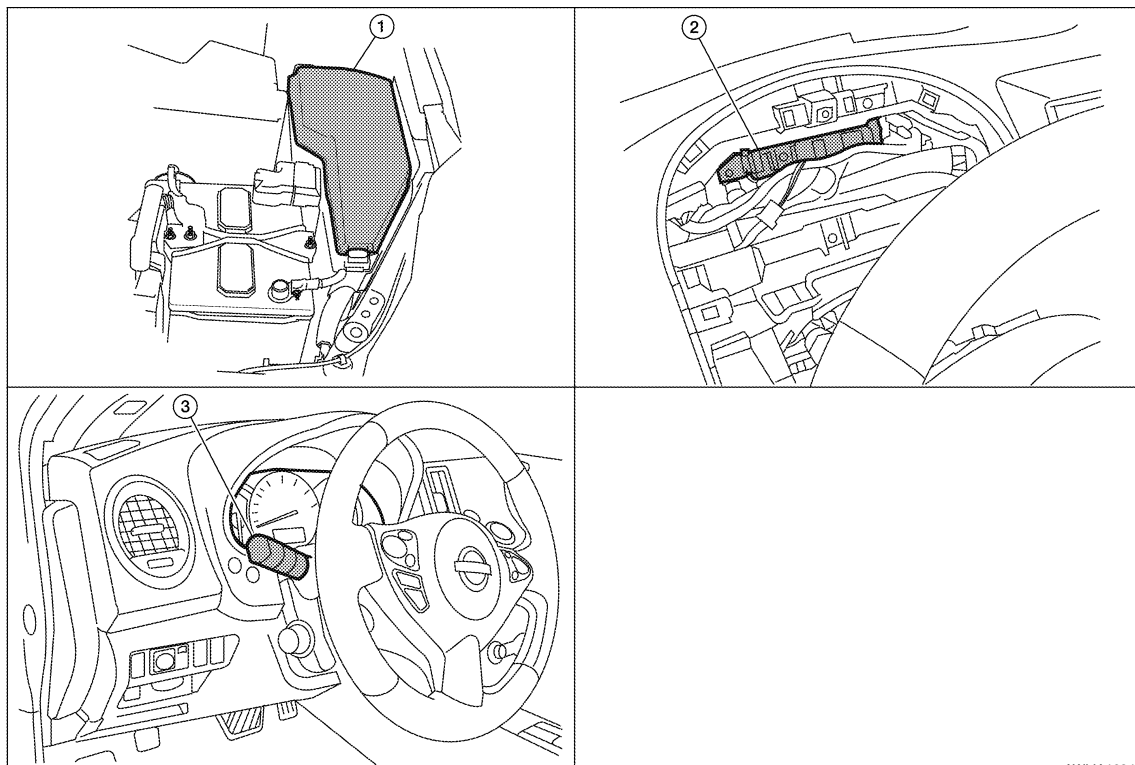

AWLIA1634ZZ

1. IPDM E/R E17, E18, E201
2. BCM M16, M17, M18, M19 (view with combination meter removed)
3. Combination switch (lighting and turn signal switch) M28

PARKING, LICENSE PLATE AND TAIL LAMPS

< FUNCTION DIAGNOSIS >

[XENON TYPE]

Component Description

INFOID:000000005460842

PARKING, LICENSE PLATE AND TAIL LAMPS OPERATION

When the lighting switch is in 1ST position, BCM detects the LIGHTING SWITCH 1ST POSITION ON. The BCM sends a parking light ON request through the CAN communication lines to the IPDM E/R. The IPDM E/R then activates the tail lamp relay which sends power to the parking and instrument illumination circuits.

EXTERIOR LAMP BATTERY SAVER CONTROL

With the lighting switch (combination switch) in the 2nd position and the ignition switch is turned from ON or ACC to OFF, the battery saver feature is activated.

Under this condition, the headlamps remain illuminated for 5 minutes unless the lighting switch position is changed. If the lighting switch position is changed, then the headlamps are turned off.

This setting can be changed by CONSULT-III. Refer to [EXL-25, "HEADLAMP : CONSULT-III Function \(BCM-HEAD LAMP\)"](#).

COMBINATION SWITCH READING SYSTEM

< FUNCTION DIAGNOSIS >

[XENON TYPE]

COMBINATION SWITCH READING SYSTEM

System Diagram

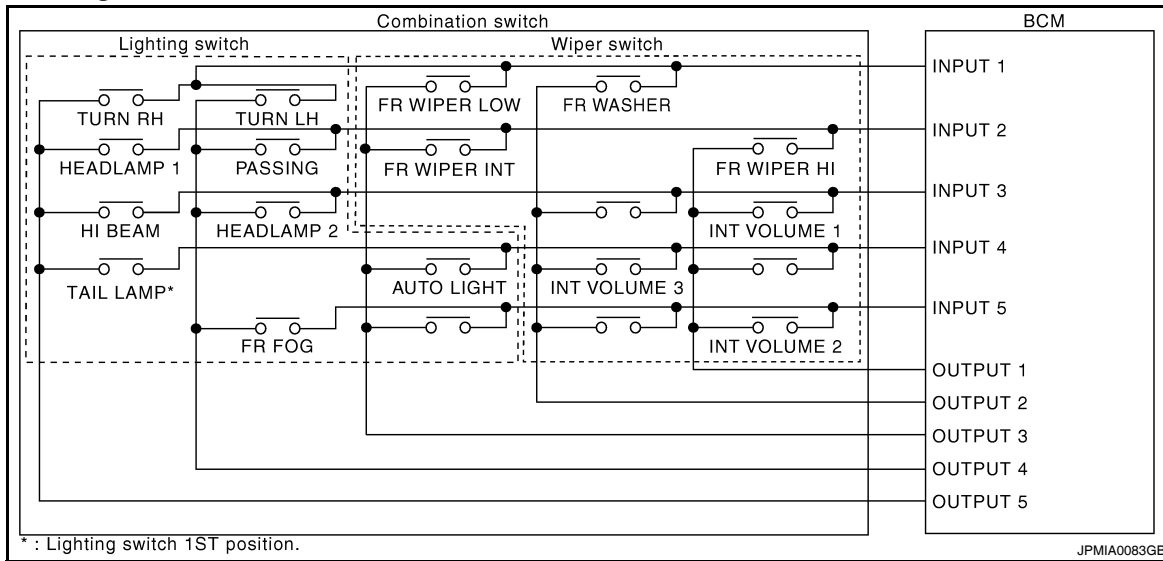

System Description

INFOID:000000005530137

OUTLINE

- BCM reads the status of the combination switch (light, turn signal, wiper and washer) and recognizes the status of each switch.
- BCM is a combination of 5 output terminals (OUTPUT 1 - 5) and 5 input terminals (INPUT 1 - 5). It reads a maximum of 20 switch status.

COMBINATION SWITCH MATRIX

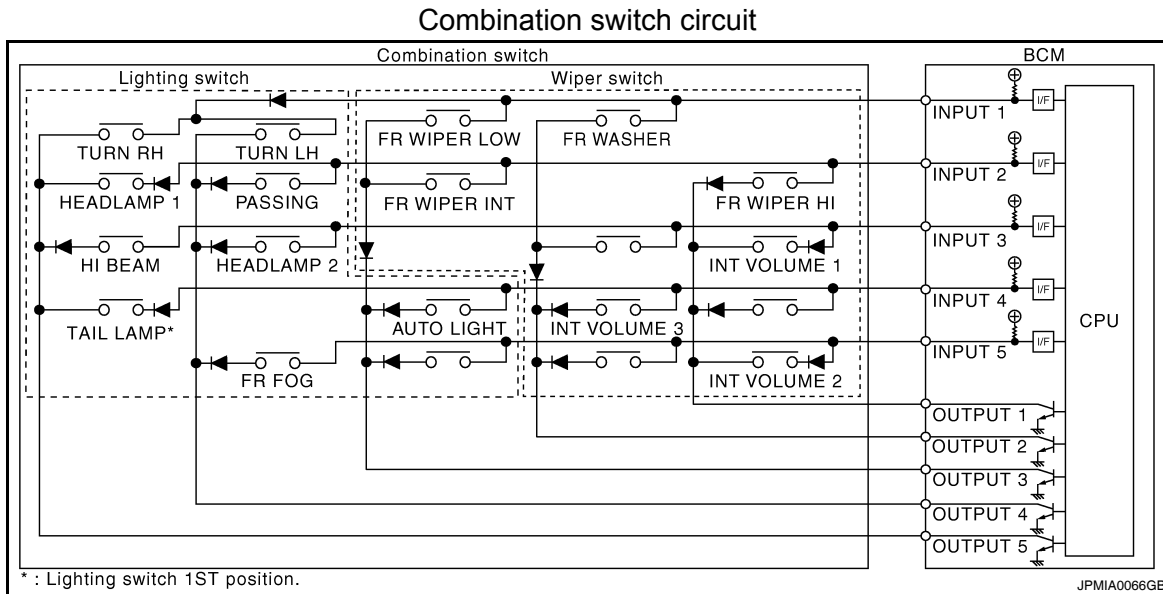

Combination switch INPUT-OUTPUT system list

System	OUTPUT 1	OUTPUT 2	OUTPUT 3	OUTPUT 4	OUTPUT 5
INPUT 1	—	FR WASHER	FR WIPER LOW	TURN LH	TURN RH
INPUT 2	FR WIPER HI	—	FR WIPER INT	PASSING	HEADLAMP 1
INPUT 3	INT VOLUME 1	—	—	HEADLAMP 2	HI BEAM

COMBINATION SWITCH READING SYSTEM

< FUNCTION DIAGNOSIS >

[XENON TYPE]

System	OUTPUT 1	OUTPUT 2	OUTPUT 3	OUTPUT 4	OUTPUT 5
INPUT 4	—	INT VOLUME 3	AUTO LIGHT	—	TAIL LAMP
INPUT 5	INT VOLUME 2	—	—	FR FOG	—

NOTE:

Headlamp has a dual system switch.

COMBINATION SWITCH READING FUNCTION

Description

- BCM reads the status of the combination switch at 10ms interval normally.

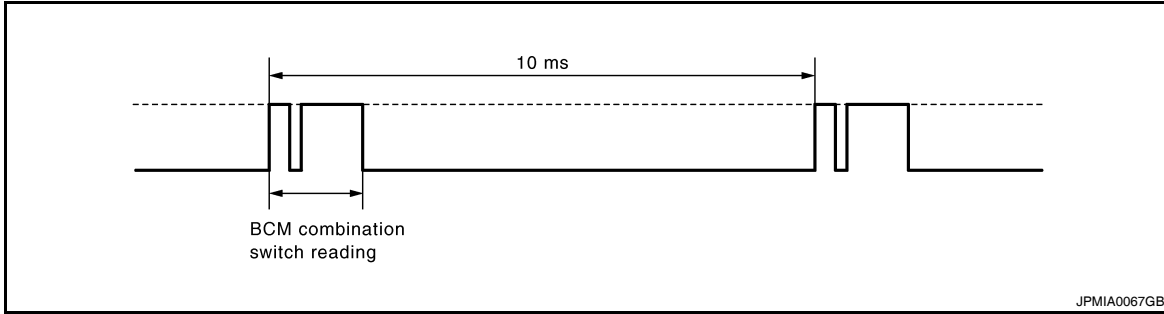

NOTE:

BCM reads the status of the combination switch at 60ms interval when BCM is controlled at low power consumption mode.

- BCM operates as follows and judges the status of the combination switch.
- INPUT 1 - 5 outputs the voltage waveforms of 5 systems simultaneously.
- It operates the transistor on OUTPUT side in the following order: OUTPUT 5 → 4 → 3 → 2 → 1.
- The voltage waveform of INPUT corresponding to the formed circuit changes according to the operation of the transistor on OUTPUT side if any (1 or more) switches are ON.
- It reads this change of the voltage as the status signal of the combination switch.

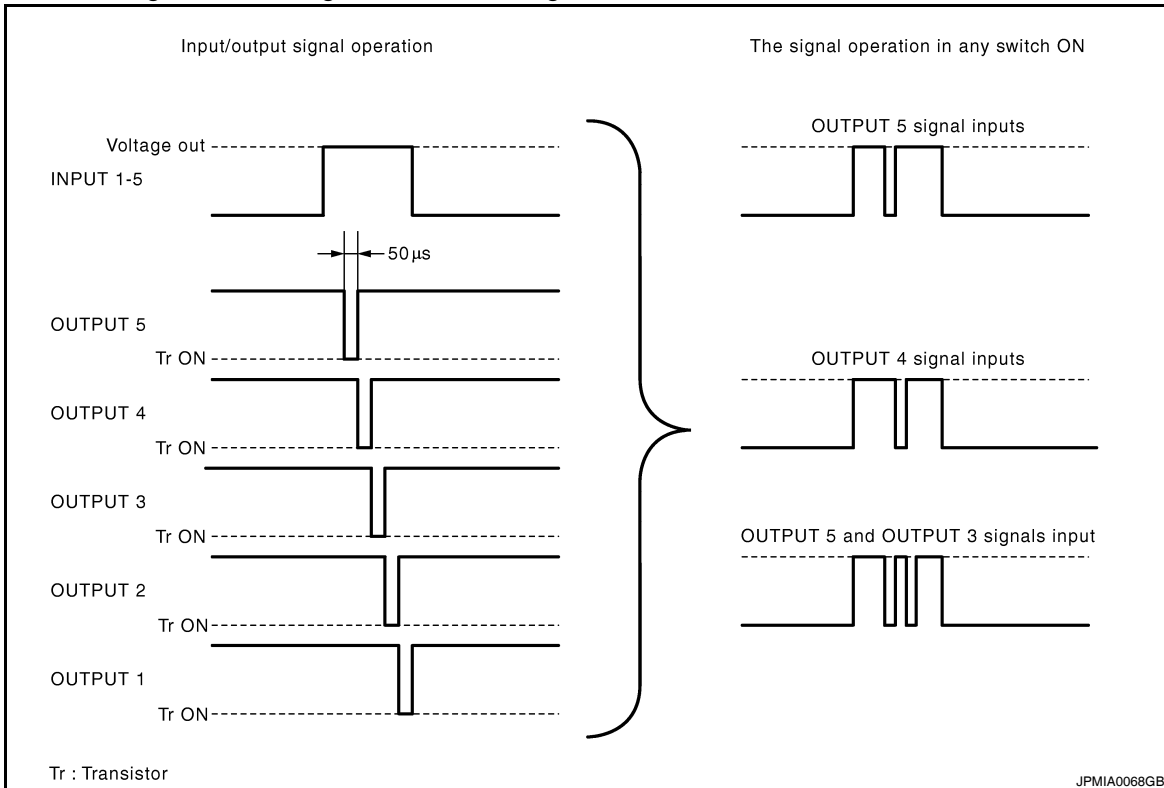

Operation Example

In the following operation example, the combination of the status signals of the combination switch is replaced as follows: INPUT 1 - 5 to "1 - 5" and OUTPUT 1 - 5 to "A - E".

Example 1: When a switch (TURN RH switch) is turned ON

COMBINATION SWITCH READING SYSTEM

[XENON TYPE]

< FUNCTION DIAGNOSIS >

- The circuit between INPUT 1 and OUTPUT 5 is formed when the TURN RH switch is turned ON.

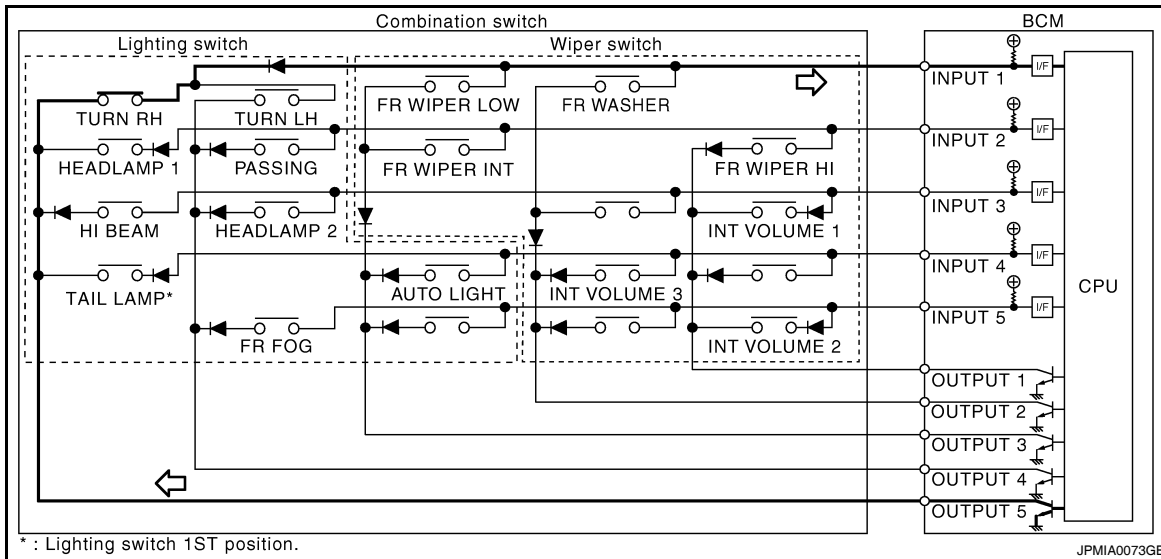

- BCM detects the combination switch status signal "1E" when the signal of OUTPUT 5 is input to INPUT 1.
- BCM judges that the TURN RH switch is ON when the signal "1E" is detected.
- Example 2: When some switches (TURN RH switch, FR WIPER LOW switch) are turned ON

Example 2: When some switches (turn RH switch, front wiper LO switch) are turned ON

- The circuits between INPUT 1 and OUTPUT 5 and between INPUT 1 and OUTPUT 3 are formed when the TURN RH switch and FR WIPER LOW switch are turned ON.

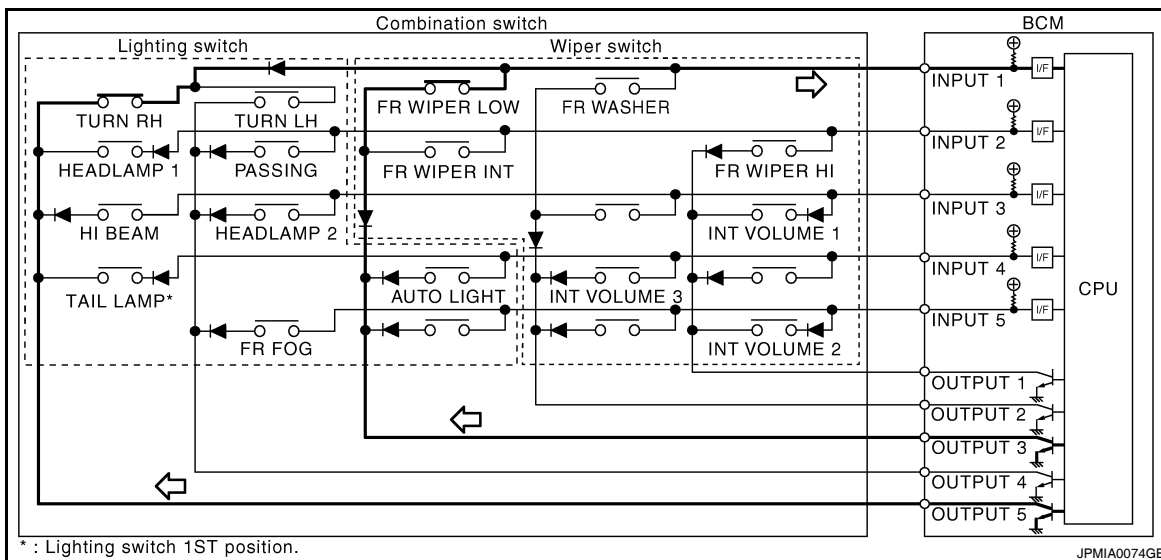

- BCM detects the combination switch status signal "1CE" when the signals of OUTPUT 3 and OUTPUT 5 are input to INPUT 1.
- BCM judges that the TURN RH switch and FR WIPER LOW switch are ON when the signal "1CE" is detected.

WIPER INTERMITTENT DIAL POSITION SETTING (FRONT WIPER INTERMITTENT OPERATION)

BCM judges the wiper intermittent dial 1 - 7 by the status of INT VOLUME 1, 2, and 3 switches.

COMBINATION SWITCH READING SYSTEM

< FUNCTION DIAGNOSIS >

[XENON TYPE]

Wiper intermittent dial position	Intermittent operation delay interval	INT VOLUME switch ON/OFF status		
		INT VOLUME 1 switch	INT VOLUME 2 switch	INT VOLUME 3 switch
1	Short ↑	ON	ON	ON
2		ON	ON	OFF
3		ON	OFF	OFF
4		OFF	OFF	OFF
5	↓ Long	OFF	OFF	ON
6		OFF	ON	ON
7		OFF	ON	OFF

DIAGNOSIS SYSTEM (BCM)

< FUNCTION DIAGNOSIS >

[XENON TYPE]

DIAGNOSIS SYSTEM (BCM)

HEADLAMP

HEADLAMP : CONSULT-III Function (BCM-HEAD LAMP)

INFOID:000000005530138

WORK SUPPORT

Service item	Setting item	Setting	
CUSTOM A/LIGHT SETTING	MODE 1*	Normal	
	MODE 2	More sensitive setting than normal setting (Turns ON earlier than normal operation.)	
	MODE 3	More sensitive setting than MODE 2 (Turns ON earlier than MODE 2.)	
	MODE 4	Less sensitive setting than normal setting (Turns ON later than normal operation.)	
BATTERY SAVER SET	ON*	With the exterior lamp battery saver function	
	OFF	Without the exterior lamp battery saver function	
ILL DELAY SET	MODE 1	45 sec.	Sets delay timer function timer operation time (All doors closed)
	MODE 2	Without the function	
	MODE 3	30 sec.	
	MODE 4	60 sec.	
	MODE 5	90 sec.	
	MODE 6	120 sec.	
	MODE 7	150 sec.	
	MODE 8	180 sec.	

* : Initial setting

DATA MONITOR

Monitor item [Unit]	Description
PUSH SW [ON/OFF]	The switch status input from push-button ignition switch
ENGINE STATE [STOP/STALL/CRANK/RUN]	The engine status received from ECM with CAN communication
VEH SPEED 1 [km/h]	The value of the vehicle speed received from combination meter with CAN communication
KEY SW-SLOT [ON/OFF]	Key switch status input from key slot

DIAGNOSIS SYSTEM (BCM)

[XENON TYPE]

< FUNCTION DIAGNOSIS >

Monitor item [Unit]	Description
TURN SIGNAL R [ON/OFF]	Each switch status that BCM judges from the combination switch reading function
TURN SIGNAL L [ON/OFF]	
TAIL LAMP SW [ON/OFF]	
HI BEAM SW [ON/OFF]	
HEAD LAMP SW1 [ON/OFF]	
HEAD LAMP SW2 [ON/OFF]	
PASSING SW [ON/OFF]	
AUTO LIGHT SW [ON/OFF]	
FR FOG SW [ON/OFF]	
DOOR SW-DR [ON/OFF]	The switch status input from front door switch LH
DOOR SW-AS [ON/OFF]	The switch status input from front door switch RH
DOOR SW-RR [ON/OFF]	The switch status input from rear door switch RH
DOOR SW-RL [ON/OFF]	The switch status input from rear door switch LH
OPTICAL SENSOR [V]	The value of exterior brightness voltage input from the optical sensor

ACTIVE TEST

Test item	Operation	Description
TAIL LAMP	ON	Transmits the Position light request signal to IPDM E/R with CAN communication to turn the tail lamp ON.
	OFF	Stops the tail lamp request signal transmission.
HEAD LAMP	HI	Transmits the high beam request signal with CAN communication to turn the headlamp (HI)
	LO	Transmits the low beam request signal with CAN communication to turn the headlamp (LO).
	OFF	Stops the high & low beam request signal transmission.
FR FOG LAMP	ON	Transmits the front fog lights request signal to IPDM E/R with CAN communication to turn the front fog lamp ON.
	OFF	Stops the front fog lights request signal transmission.

FLASHER

FLASHER : CONSULT-III Function (BCM-FLASHER)

INFOID:000000005530139

WORK SUPPORT

DIAGNOSIS SYSTEM (BCM)

< FUNCTION DIAGNOSIS >

[XENON TYPE]

Service item	Setting item	Setting	
HAZARD ANSWER BACK	Lock Only*	Activated when locking.	Sets the hazard warning lamp answer back activation when the door is lock/unlock with the request switch or the key fob.
	Unlock Only	Activated when unlocking.	
	Lock/unlock	Activated when locking/unlocking	
	OFF	Not activated	

* : Initial setting

DATA MONITOR

Monitor item [Unit]	Description
REQ SW-DR [ON/OFF]	The switch status input from the request switch (driver side)
REQ SW-AS [ON/OFF]	The switch status input from the request switch (passenger side)
PUSH SW [ON/OFF]	The switch status input from the push-button ignition switch
TURN SIGNAL R [ON/OFF]	Each switch condition that BCM judges from the combination switch reading function
TURN SIGNAL L [ON/OFF]	
HAZARD SW [ON/OFF]	The switch status input from the hazard warning switch
RKE-LOCK [ON/OFF]	The lock signal status received from the keyless receiver
RKE-UNLOCK [ON/OFF]	The unlock signal status received from the keyless receiver
RKE-PANIC [ON/OFF]	The panic alarm signal status received from the keyless receiver

ACTIVE TEST

Test item	Operation	Description
FLASHER	RH	Blinks right turn signal lamp.
	LH	Blinks left turn signal lamp.
	OFF	Turns turn signal lamps (right and left) OFF.

COMB SW

COMB SW : CONSULT-III Function (BCM-COMB SW)

INFOID:000000005530140

DATA MONITOR

Monitor item [UNIT]	Description
FR WIPER HI [OFF/ON]	Displays the status of the FR WIPER HI switch in combination switch judged by BCM with the combination switch reading function.
FR WIPER LOW [OFF/ON]	Displays the status of the FR WIPER LOW switch in combination switch judged by BCM with the combination switch reading function.
FR WASHER SW [OFF/ON]	Displays the status of the FR WASHER switch in combination switch judged by BCM with the combination switch reading function.
FR WIPER INT [OFF/ON]	Displays the status of the FR WIPER INT switch in combination switch judged by BCM with the combination switch reading function.

DIAGNOSIS SYSTEM (BCM)

[XENON TYPE]

< FUNCTION DIAGNOSIS >

Monitor item [UNIT]	Description
FR WIPER STOP [OFF/ON]	Displays the status of the front wiper stop position signal received from IPDM E/R via CAN communication.
INT VOLUME [1 - 7]	Displays the status of wiper intermittent dial position judged by BCM with the combination switch reading function
TURN SIGNAL R [OFF/ON]	Displays the status of theTURN RH switch in combination switch judged by BCM with the combination switch reading function.
TURN SIGNAL L [OFF/ON]	Displays the status of theTURN LH switch in combination switch judged by BCM with the combination switch reading function.
TAIL LAMP SW [OFF/ON]	Displays the status of the TAIL LAMP switch in combination switch judged by BCM with the combination switch reading function.
HI BEAM SW [OFF/ON]	Displays the status of the HI BEAM switch in combination switch judged by BCM with the combination switch reading function.
HEAD LAMP SW 1 [OFF/ON]	Displays the status of the HEADLAMP 1 switch in combination switch judged by BCM with the combination switch reading function.
HEAD LAMP SW 2 [OFF/ON]	Displays the status of the HEADLAMP 2 switch in combination switch judged by BCM with the combination switch reading function.
PASSING SW [OFF/ON]	Displays the status of the PASSING switch in combination switch judged by BCM with the combination switch reading function.
AUTO LIGHT SW [OFF/ON]	Displays the status of the AUTO LIGHT switch in combination switch judged by BCM with the combination switch reading function.
FR FOG SW [OFF/ON]	Displays the status of the FR FOG switch in combination switch judged by BCM with the combination switch reading function.

DIAGNOSIS SYSTEM (IPDM E/R)

Diagnosis Description

INFOID:000000005530260

AUTO ACTIVE TEST

Description

In auto active test mode, the IPDM E/R sends a drive signal to the following systems to check their operation.

- Oil pressure warning lamp
- Front wiper (LO, HI)
- Parking lamps
- License plate lamps
- Tail lamps
- Front fog lamps (if equipped)
- Headlamps (LO, HI)
- A/C compressor (magnet clutch)
- Cooling fans

Operation Procedure

1. Close the hood and lift the wiper arms from the windshield. (Prevent windshield damage due to wiper operation)
NOTE:
 When auto active test is performed with hood opened, sprinkle water on windshield beforehand.
2. Turn ignition switch OFF.
3. Turn the ignition switch ON, and within 20 seconds, press the front door switch LH 10 times. Then turn the ignition switch OFF.
CAUTION:
Close front door RH.
4. Turn the ignition switch ON within 10 seconds. After that the horn sounds once and the auto active test starts.
5. The oil pressure warning lamp starts blinking when the auto active test starts.
6. After a series of the following operations is repeated 3 times, auto active test is completed.

NOTE:

When auto active test mode has to be cancelled halfway through test, turn ignition switch OFF.

CAUTION:

- **If auto active test mode cannot be actuated, check door switch system. Refer to [DLK-68](#), "[Component Function Check](#)".**
- **Do not start the engine.**

Inspection in Auto Active Test Mode

When auto active test mode is actuated, the following 6 steps are repeated 3 times.

Operation sequence	Inspection Location	Operation
1	Oil pressure warning lamp	Blinks continuously during operation of auto active test
2	Front wiper	LO for 5 seconds → HI for 5 seconds
3	<ul style="list-style-type: none"> • Parking lamps • License plate lamps • Tail lamps • Front fog lamps (if equipped) 	10 seconds
4	Headlamps	LO ↔ HI 5 times
5	A/C compressor (magnet clutch)	ON ↔ OFF 5 times
6*	Cooling fans	MID for 5 seconds → HI for 5 seconds

*: Outputs duty ratio of 50% for 5 seconds → duty ratio of 100% for 5 seconds on the cooling fan control module.

DIAGNOSIS SYSTEM (IPDM E/R)

< FUNCTION DIAGNOSIS >

[XENON TYPE]

Concept of auto active test

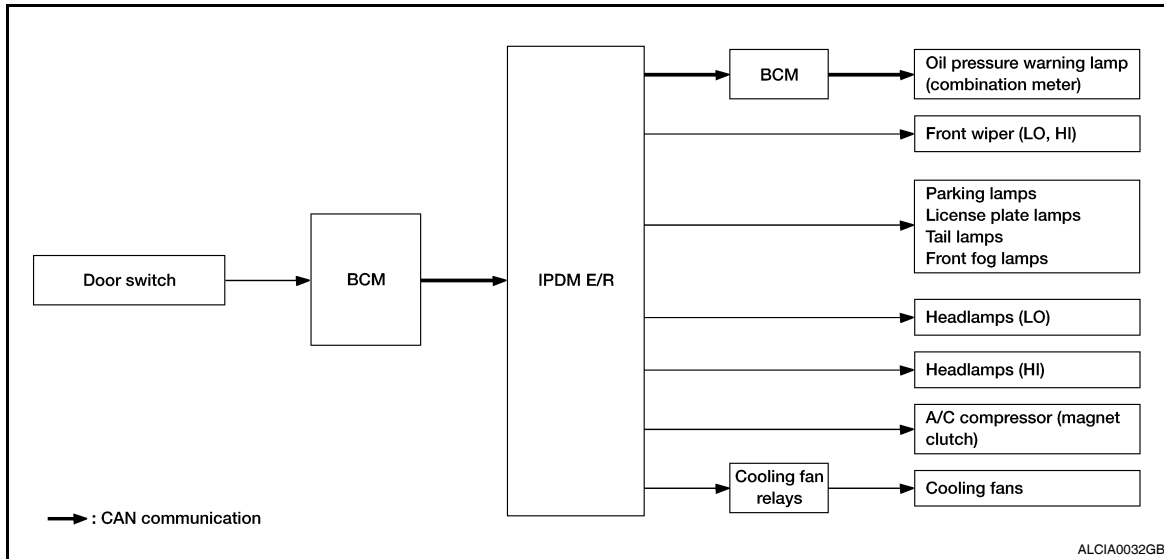

- IPDM E/R starts the auto active test with the door switch signals transmitted by BCM via CAN communication. Therefore, the CAN communication line between IPDM E/R and BCM is considered normal if the auto active test starts successfully.
- The auto active test facilitates troubleshooting if any systems controlled by IPDM E/R cannot be operated.

Diagnosis chart in auto active test mode

Symptom	Inspection contents	Possible cause
Any of the following components do not operate <ul style="list-style-type: none"> • Parking lamps • License plate lamps • Tail lamps • Front fog lamps (if equipped) • Headlamp (HI, LO) • Front wiper 	Perform auto active test. Does the applicable system operate?	YES BCM signal input circuit
		NO <ul style="list-style-type: none"> • Lamp or motor • Lamp or motor ground circuit • Harness or connector between IPDM E/R and applicable system • IPDM E/R
A/C compressor does not operate	Perform auto active test. Does the magnet clutch operate?	YES <ul style="list-style-type: none"> • Combination meter signal input circuit • CAN communication signal between combination meter and ECM • CAN communication signal between ECM and IPDM E/R
		NO <ul style="list-style-type: none"> • Magnet clutch • Harness or connector between IPDM E/R and magnet clutch • IPDM E/R

DIAGNOSIS SYSTEM (IPDM E/R)

< FUNCTION DIAGNOSIS >

[XENON TYPE]

Symptom	Inspection contents	Possible cause
Oil pressure warning lamp does not operate	Perform auto active test. Does the oil pressure warning lamp blink?	YES <ul style="list-style-type: none"> • Harness or connector between IPDM E/R and oil pressure switch • Oil pressure switch • IPDM E/R
		NO <ul style="list-style-type: none"> • CAN communication signal between IPDM E/R and BCM • CAN communication signal between BCM and combination meter • Combination meter
Cooling fan does not operate	Perform auto active test. Does the cooling fan operate?	YES <ul style="list-style-type: none"> • ECM signal input circuit • CAN communication signal between ECM and IPDM E/R
		NO <ul style="list-style-type: none"> • Cooling fan • Harness or connector between cooling fan and cooling fan relays • Cooling fan relays • Harness or connector between IPDM E/R and cooling fan relays • IPDM E/R

CONSULT - III Function (IPDM E/R)

INFOID:000000005530261

APPLICATION ITEM

CONSULT-III performs the following functions via CAN communication with IPDM E/R.

Diagnosis mode	Description
ECU Identification	Allows confirmation of IPDM E/R part number.
Self Diagnostic Result	Displays the diagnosis results judged by IPDM E/R.
Data Monitor	Displays the real-time input/output data from IPDM E/R input/output data.
Active Test	IPDM E/R can provide a drive signal to electronic components to check their operations.
CAN Diag Support Monitor	The results of transmit/receive diagnosis of CAN communication can be read.

SELF DIAGNOSTIC

Refer to [EXL-325, "DTC Index"](#).

DATA MONITOR

Monitor item

Monitor Item [Unit]	MAIN SIGNALS	Description
MOTOR FAN REQ [1,2,3,4]	×	Displays the value of the cooling fan speed signal received from ECM via CAN communication.
AC COMP REQ [Off/On]	×	Displays the status of the A/C compressor request signal received from ECM via CAN communication.
TAIL&CLR REQ [Off/On]	×	Displays the status of the position light request signal received from BCM via CAN communication.
HL LO REQ [Off/On]	×	Displays the status of the low beam request signal received from BCM via CAN communication.
HL HI REQ [Off/On]	×	Displays the status of the high beam request signal received from BCM via CAN communication.

DIAGNOSIS SYSTEM (IPDM E/R)

[XENON TYPE]

< FUNCTION DIAGNOSIS >

Monitor Item [Unit]	MAIN SIG- NALS	Description
FR FOG REQ [Off/On]	×	Displays the status of the front fog light request signal received from BCM via CAN communication.
FR WIP REQ [Stop/1LOW/Low/Hi]	×	Displays the status of the front wiper request signal received from BCM via CAN communication.
WIP AUTO STOP [STOP P/ACT P]	×	Displays the status of the front wiper auto stop signal judged by IPDM E/R.
WIP PROT [Off/BLOCK]	×	Displays the status of the front wiper fail-safe operation judged by IPDM E/R.
IGN RLY1 -REQ [Off/On]		Displays the status of the ignition switch ON signal received from BCM via CAN communication.
IGN RLY [Off/On]	×	Displays the status of the ignition relay judged by IPDM E/R.
PUSH SW [Off/On]		Displays the status of the push-button ignition switch judged by IPDM E/R.
INTER/NP SW [Off/On]		Displays the status of the CVT shift position judged by IPDM E/R.
ST RLY CONT [Off/On]		Displays the status of the starter relay status signal received from BCM via CAN communication.
IHBT RLY -REQ [Off/On]		Displays the status of the starter control relay signal received from BCM via CAN communication.
ST/INH RLY [Off/ ST /INH]		Displays the status of the starter relay and starter control relay judged by IPDM E/R.
DETENT SW [Off/On]		Displays the status of the CVT shift selector (detention switch) judged by IPDM E/R.
S/L RLY -REQ ¹ [Off/On]		Displays the status of the steering lock relay request received from BCM via CAN communication.
S/L STATE ¹ [LOCK/UNLK/UNKWN]		Displays the status of the electronic steering column lock judged by IPDM E/R.
DTRL REQ [Off]		Displays the status of the daytime light request signal received from BCM via CAN communication.
OIL P SW [Open/Close]		Displays the status of the oil pressure switch judged by IPDM E/R.
THFT HRN REQ [Off/On]		Displays the status of the theft warning horn request signal received from BCM via CAN communication.
HORN CHIRP [Off/On]		Displays the status of the horn reminder signal received from BCM via CAN communication.

1: Early production

ACTIVE TEST

Test item

Test item	Operation	Description
HORN	On	Operates horn relay 1 and horn relay 2 for 20 ms.
	Off	OFF
FRONT WIPER	Lo	Operates the front wiper relay.
	Hi	Operates the front wiper relay and front wiper high relay.
MOTOR FAN	1	OFF
	2	Outputs 50% pulse duty signal (PWM signal) to the cooling fan control module.
	3	Outputs 80% pulse duty signal (PWM signal) to the cooling fan control module.
	4	Outputs 100% pulse duty signal (PWM signal) to the cooling fan control module.

DIAGNOSIS SYSTEM (IPDM E/R)

< FUNCTION DIAGNOSIS >

[XENON TYPE]

Test item	Operation	Description
EXTERNAL LAMPS	Off	OFF
	TAIL	Operates the tail lamp relay.
	Lo	Operates the headlamp low relay.
	Hi	Operates the headlamp low relay and ON/OFF the headlamp high relay at 1 second intervals.
	Fog	Operates the front fog lamp relay.

A
B
C
D
E
F
G
H
I
J
K
EXL
M
N
O
P

EXL

COMPONENT DIAGNOSIS

POWER SUPPLY AND GROUND CIRCUIT

BCM (BODY CONTROL MODULE)

BCM (BODY CONTROL MODULE) : Diagnosis Procedure

INFOID:000000005530141

Regarding Wiring Diagram information, refer to [EXL-122, "Wiring Diagram"](#).

1. CHECK FUSE AND FUSIBLE LINK

Check if the following BCM fuses or fusible link are blown.

Terminal No.	Signal name	Fuse and fusible link No.
1	Battery power supply	H
11		10
24		7

Is the fuse or fusible link blown?

- YES >> Replace the blown fuse or fusible link after repairing the affected circuit.
 NO >> GO TO 2

2. CHECK POWER SUPPLY CIRCUIT

1. Turn ignition switch OFF.
2. Disconnect BCM.
3. Check voltage between BCM harness connector and ground.

Terminals		Voltage (Approx.)
(+)	(-)	
BCM		Ground Battery voltage
Connector	Terminal	
M16 (A)	1	
M17 (B)	11	
M18 (C)	24	

Is the measurement normal?

- YES >> GO TO 3
 NO >> Repair or replace harness.

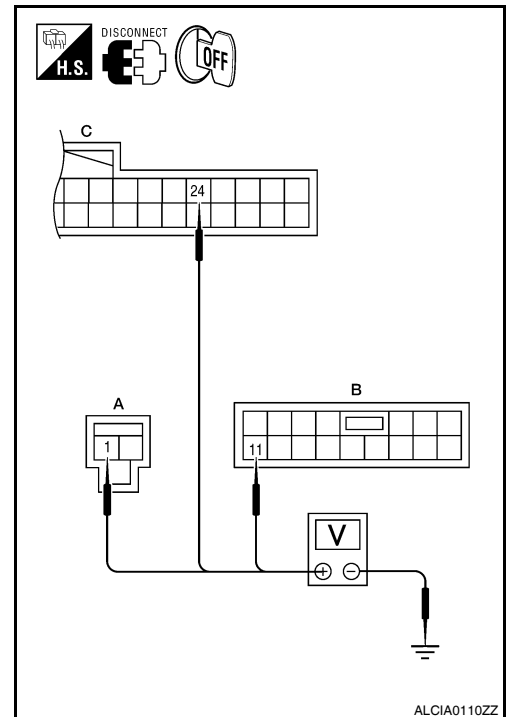

3. CHECK GROUND CIRCUIT

POWER SUPPLY AND GROUND CIRCUIT

< COMPONENT DIAGNOSIS >

[XENON TYPE]

Check continuity between BCM harness connector and ground.

BCM		Ground	Continuity
Connector	Terminal		
M17	13		Yes

Does continuity exist?

- YES >> Inspection End.
- NO >> Repair or replace harness.

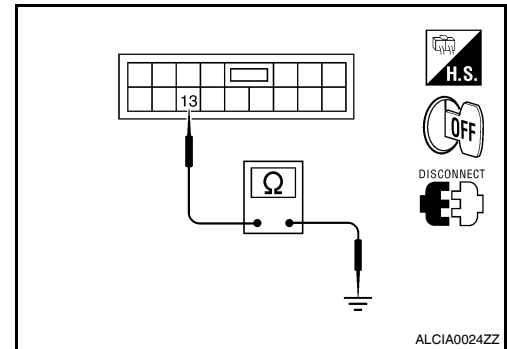

BCM (BODY CONTROL MODULE) : Special Repair Requirement

INFOID:000000005530142

1. REQUIRED WORK WHEN REPLACING BCM

Initialize control unit. Refer to [BCS-6, "CONFIGURATION \(BCM\) : Special Repair Requirement"](#).

>> Work End.

IPDM E/R (INTELLIGENT POWER DISTRIBUTION MODULE ENGINE ROOM)

IPDM E/R (INTELLIGENT POWER DISTRIBUTION MODULE ENGINE ROOM) : Diagnosis Procedure

INFOID:000000005530262

Regarding Wiring Diagram information, refer to [EXL-144, "Wiring Diagram"](#).

1. CHECK FUSES AND FUSIBLE LINK

Check that the following IPDM E/R fuses or fusible link are not blown.

Terminal No.	Signal name	Fuses and fusible link No.
1, 2	Battery power supply	B, D
—		42
—		43

Is the fuse blown?

- YES >> Replace the blown fuse or fusible link after repairing the affected circuit.
- NO >> GO TO 2

2. CHECK POWER SUPPLY CIRCUIT

1. Turn ignition switch OFF.
2. Disconnect IPDM E/R connectors.
3. Check voltage between IPDM E/R harness connector and ground.

Terminals		Ground	Voltage (V) (Approx.)
(+)	(-)		
IPDM E/R		Ground	Battery voltage
Connector	Terminal		
E16	1 2		

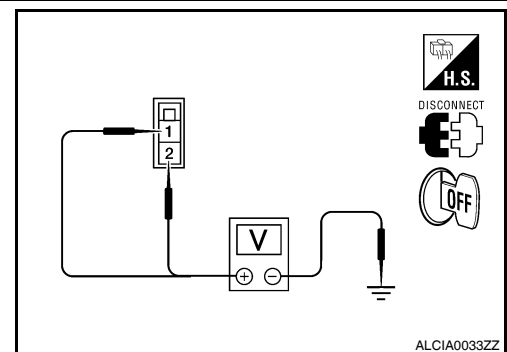

Is the measurement value normal?

- YES >> GO TO 3
- NO >> Repair harness or connector.

POWER SUPPLY AND GROUND CIRCUIT

< COMPONENT DIAGNOSIS >

[XENON TYPE]

3. CHECK GROUND CIRCUIT

Check continuity between IPDM E/R harness connectors and ground.

IPDM E/R		Ground	Continuity
Connector	Terminal		
A: E18	12		Yes
B: E17	41		

Does continuity exist?

- YES >> Inspection End.
- NO >> Repair harness or connector.

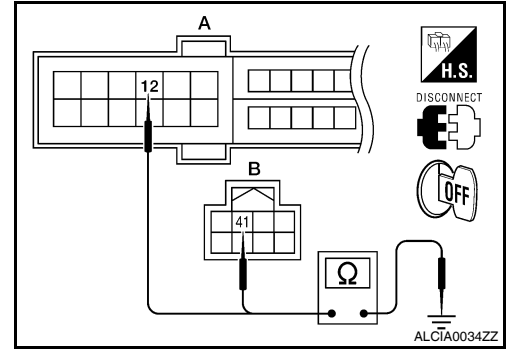

HEADLAMP (HI) CIRCUIT

< COMPONENT DIAGNOSIS >

[XENON TYPE]

HEADLAMP (HI) CIRCUIT

Description

INFOID:000000005460853

The IPDM E/R (intelligent power distribution module engine room) controls the headlamp high relay based on inputs from the BCM over the CAN communication lines. When the headlamp high relay is energized, power flows through fuses 48 and 49, located in the IPDM E/R. Power then flows to the front combination lamps to the headlamp high beam.

Component Function Check

INFOID:000000005460854

1. CHECK HEADLAMP (HI) OPERATION

⊗ WITHOUT CONSULT-III

1. Start IPDM E/R auto active test. Refer to [PCS-14, "Diagnosis Description"](#).
2. Check that the headlamp switches to the high beam.

NOTE:

HI/LO is repeated 1 second each when using the IPDM E/R auto active test.

Ⓜ CONSULT-III

1. Select "EXTERNAL LAMPS" of IPDM E/R active test item.
2. While operating the test item, check that the headlamp switches to the high beam.

HI : Headlamp switches to the high beam.

OFF : Headlamp OFF

Does the headlamp switch to the high beam?

YES >> Headlamp (HI) circuit is normal.

NO >> Refer to [EXL-37, "Diagnosis Procedure"](#).

Diagnosis Procedure

INFOID:000000005460855

Regarding Wiring Diagram information, refer to [EXL-53, "Wiring Diagram"](#).

1. CHECK HEADLAMP (HI) FUSES

1. Turn the ignition switch OFF.
2. Check that the following fuses are not open.

Unit	Location	Fuse No.	Capacity
Headlamp HI (LH)	IPDM E/R	48	10A
Headlamp HI (RH)	IPDM E/R	49	10A

Is the fuse open?

YES >> Repair the harness and replace the fuse.

NO >> GO TO 2.

2. CHECK HEADLAMP (HI) OUTPUT VOLTAGE

Ⓜ CONSULT-III ACTIVE TEST

1. Turn the ignition switch OFF.
2. Disconnect the front combination lamp connector.
3. Turn the ignition switch ON.
4. Select "EXTERNAL LAMPS" of IPDM E/R active test item.

HEADLAMP (HI) CIRCUIT

[XENON TYPE]

< COMPONENT DIAGNOSIS >

5. With EXTERNAL LAMP ON, check the voltage between the combination lamp connector and ground.

(+)		Terminal	(-)	Voltage
Connector				
RH	E222	3	Ground	Battery voltage
LH	E213	3		

Is battery voltage present?

- YES >> GO TO 4.
NO >> GO TO 3.

3. CHECK HEADLAMP (HI) CIRCUIT FOR OPEN

- Turn the ignition switch OFF.
- Disconnect IPDM E/R connector.
- Check continuity between the IPDM E/R harness connector and the front combination lamp harness connector.

A		Terminal	B		Continuity
Connector			Connector	Terminal	
RH	E200	89	E222	3	Yes
LH		90	E213	3	

Does continuity exist?

- YES >> Replace IPDM E/R. Refer to [PCS-41. "Removal and Installation"](#).
NO >> Repair the harnesses or connectors.

4. CHECK FRONT COMBINATION LAMP (HI) GROUND CIRCUIT

Check continuity between the front combination lamp harness connector terminal and ground.

Connector	Terminal	—	Continuity
RH	E222	Ground	Yes
LH	E213		

Does continuity exist?

- YES >> Inspect the headlamp bulb.
NO >> Repair the harness.

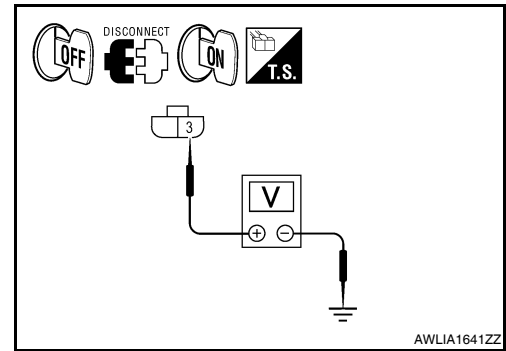

AWLIA1641ZZ

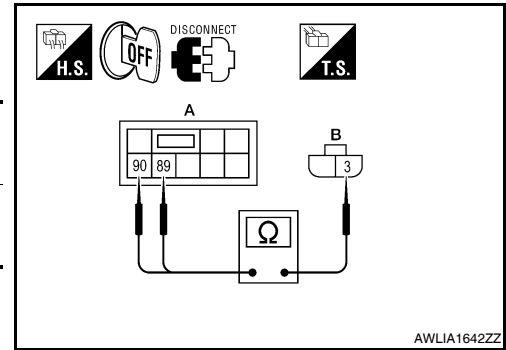

AWLIA1642ZZ

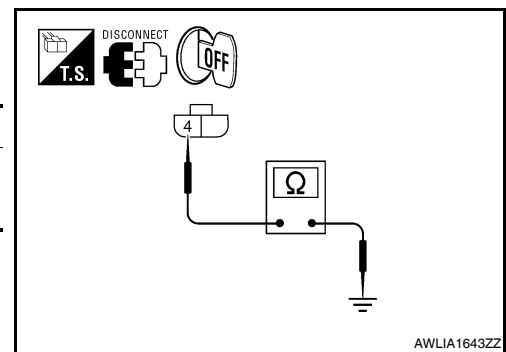

AWLIA1643ZZ

HEADLAMP (LO) CIRCUIT

< COMPONENT DIAGNOSIS >

[XENON TYPE]

HEADLAMP (LO) CIRCUIT

Description

INFOID:000000005460856

The IPDM E/R (intelligent power distribution module engine room) controls the headlamp low relay based on inputs from the BCM over the CAN communication lines. When the headlamp low relay is energized, power flows through fuses 51 and 52, located in the IPDM E/R. Power then flows to the front combination lamps to the headlamp low beam.

Component Function Check

INFOID:000000005460857

1. CHECK HEADLAMP (LO) OPERATION

⊗ WITHOUT CONSULT-III

1. Start IPDM E/R auto active test. Refer to [PCS-14, "Diagnosis Description"](#).
2. Check that the headlamp is turned ON.

NOTE:

HI/LO is repeated 1 second each when using the IPDM E/R auto active test.

Ⓜ CONSULT-III

1. Select "EXTERNAL LAMPS" of IPDM E/R active test item.
2. While operating the test item, check that the headlamp is turned ON.

LO : Headlamp ON

OFF : Headlamp OFF

Is the headlamp turned ON?

YES >> Headlamp (LO) is normal.

NO >> Refer to [EXL-39, "Diagnosis Procedure"](#).

Diagnosis Procedure

INFOID:000000005460858

Regarding Wiring Diagram information, refer to [EXL-53, "Wiring Diagram"](#).

1. CHECK HEADLAMP (LO) FUSES

1. Turn the ignition switch OFF.
2. Check that the following fuses are not open.

Unit	Location	Fuse No.	Capacity
Headlamp LO (LH)	IPDM E/R	51	15A
Headlamp LO (RH)	IPDM E/R	52	15A

Is the fuse open?

YES >> Repair the harness and replace the fuse.

NO >> GO TO 2.

2. CHECK HEADLAMP (LO) OUTPUT VOLTAGE

Ⓜ CONSULT-III

1. Turn the ignition switch OFF.
2. Disconnect the front combination lamp connector.
3. Turn the ignition switch ON.
4. Select "EXTERNAL LAMPS" of IPDM E/R active test item.

HEADLAMP (LO) CIRCUIT

[XENON TYPE]

< COMPONENT DIAGNOSIS >

5. With EXTERNAL LAMPS ON, check the voltage between the combination lamp connector and ground.

(+)		Terminal	(-)	Voltage
Connector				
RH	E232	1	Ground	Battery voltage
LH	E231	1		

Is battery voltage present?

- YES >> GO TO 4.
NO >> GO TO 3.

3. CHECK HEADLAMP (LO) CIRCUIT FOR OPEN

1. Turn the ignition switch OFF.
2. Disconnect IPDM E/R connector.
3. Check continuity between the IPDM E/R harness connector and the front combination lamp harness connector.

A		B		Continuity
Connector	Terminal	Connector	Terminal	
RH	E200	83	E232	Yes
LH		84	E231	

Does continuity exist?

- YES >> Replace the IPDM E/R. Refer to [PCS-41. "Removal and Installation"](#).
NO >> Repair the harnesses or connectors.

4. CHECK FRONT COMBINATION LAMP (LO) GROUND CIRCUIT

Check continuity between the front combination lamp harness connector terminal and ground.

Connector	Terminal	—	Continuity
RH	E232	Ground	Yes
LH	E231		

Does continuity exist?

- YES >> Inspect the headlamp bulb.
NO >> Repair the harness.

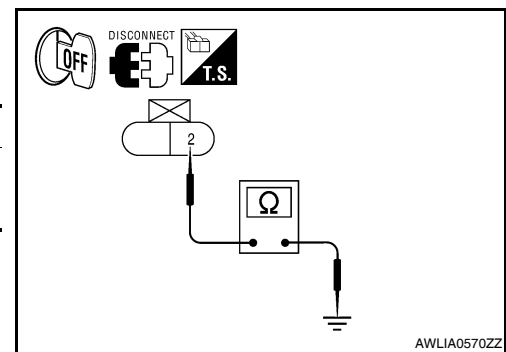
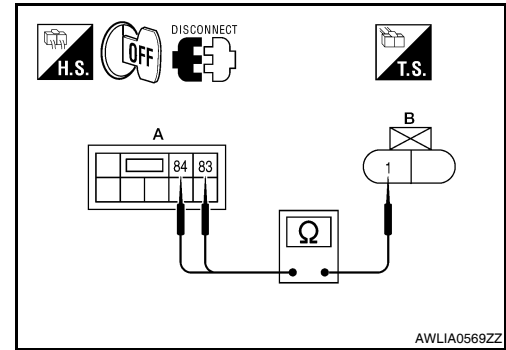
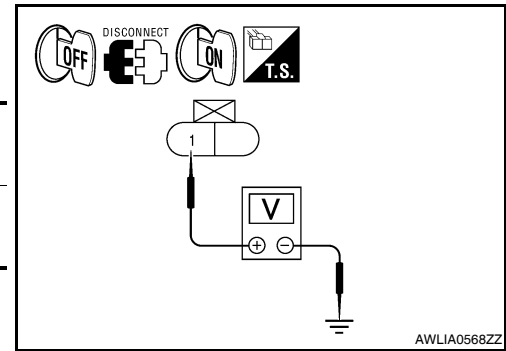

FRONT FOG LAMP CIRCUIT

< COMPONENT DIAGNOSIS >

[XENON TYPE]

FRONT FOG LAMP CIRCUIT

Description

INFOID:000000005460859

The IPDM E/R (intelligent power distribution module engine room) controls the front fog lamp relay based on inputs from the BCM over the CAN communication lines. When the front fog lamp relay is energized, power flows from the front fog lamp relay in the IPDM E/R to the front fog lamps.

Component Function Check

INFOID:000000005460860

1. CHECK FRONT FOG LAMP OPERATION

WITHOUT CONSULT-III

1. Activate IPDM E/R auto active test. Refer to [PCS-14, "Diagnosis Description"](#).
2. Check that the front fog lamp is turned ON.

CONSULT-III

1. Select "EXTERNAL LAMPS" of IPDM E/R active test item.
2. While operating the test item, check that the front fog lamp is turned ON.

FOG : Front fog lamp ON

OFF : Front fog lamp OFF

Is the front fog lamp turned ON?

- YES >> Front fog lamp circuit is normal.
NO >> Refer to [EXL-41, "Diagnosis Procedure"](#).

Diagnosis Procedure

INFOID:000000005460861

Regarding Wiring Diagram information, refer to [EXL-71, "Wiring Diagram"](#).

1. CHECK FRONT FOG LAMP FUSE

1. Turn the ignition switch OFF.
2. Check that the following fuses are not open.

Unit	Location	Fuse No.	Capacity
Front fog lamp	IPDM E/R	53	15A

Is the fuse open?

- YES >> Repair the harness and replace the fuse.
NO >> GO TO 2.

2. CHECK FRONT FOG LAMP OUTPUT VOLTAGE

CONSULT-III

1. Turn the ignition switch OFF.
2. Disconnect the front fog lamp connector.
3. Turn the ignition switch ON.
4. Select "EXTERNAL LAMPS" of IPDM E/R active test item.

FRONT FOG LAMP CIRCUIT

[XENON TYPE]

< COMPONENT DIAGNOSIS >

- With EXTERNAL LAMPS ON, check the voltage between the fog lamp connector and ground.

(+)		Terminal	(-)	Voltage
Connector				
LH	E214	1	Ground	Battery voltage
RH	E227	1		

Is battery voltage present?

- YES >> GO TO 4.
NO >> GO TO 3.

3. CHECK FRONT FOG LAMP OPEN CIRCUIT

- Turn the ignition switch OFF.
- Disconnect IPDM E/R connector.
- Check continuity between the IPDM E/R harness connector and the front fog lamp harness connector.

A		B		Continuity
Connector	Terminal	Connector	Terminal	
RH	E200	E227	86	Yes
LH			87	
		E214	1	

Does continuity exist?

- YES >> Replace the IPDM E/R. Refer to [PCS-41. "Removal and Installation"](#).
NO >> Repair the harnesses or connectors.

4. CHECK FRONT FOG LAMP GROUND CIRCUIT

Check continuity between the front fog lamp harness connector terminal and ground.

Connector	Terminal	—	Continuity
RH	E227	Ground	Yes
LH	E214		

Does continuity exist?

- YES >> Inspect the fog lamp bulb.
NO >> Repair the harness.

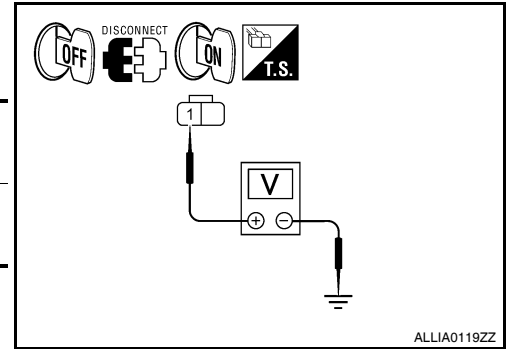

ALLIA0119ZZ

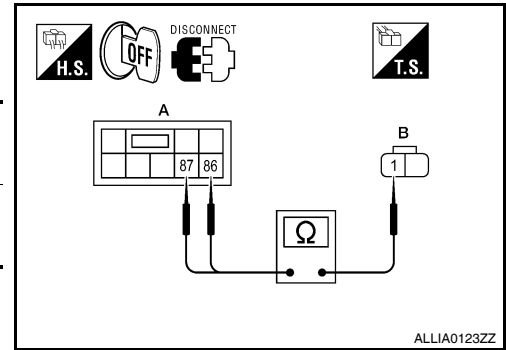

ALLIA0123ZZ

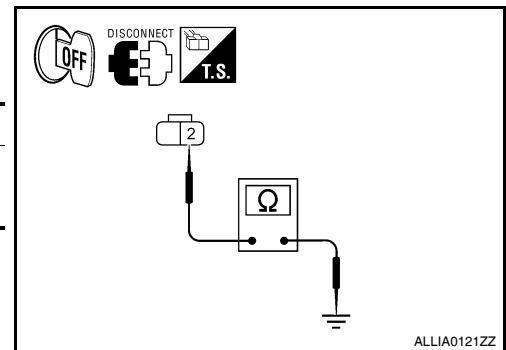

ALLIA0121ZZ

PARKING LAMP CIRCUIT

< COMPONENT DIAGNOSIS >

[XENON TYPE]

PARKING LAMP CIRCUIT

Description

INFOID:000000005460862

The IPDM E/R (intelligent power distribution module engine room) controls the tail lamp relay based on inputs from the BCM over the CAN communication lines. When the tail lamp relay is energized, power flows through fuses 46 and 47, located in the IPDM E/R. Power then flows to the front and rear combination lamps.

Component Function Check

INFOID:000000005460863

1. CHECK PARKING LAMP OPERATION

WITHOUT CONSULT-III

1. Activate IPDM E/R auto active test. Refer to [PCS-14, "Diagnosis Description"](#).
2. Check that the parking lamp is turned ON.

CONSULT-III

1. Select "EXTERNAL LAMPS" of IPDM E/R active test item.
2. While operating the test item, check that the parking lamp is turned ON.

TAIL : Parking lamp ON
OFF : Parking lamp OFF

Is the parking lamp turned ON?

- YES >> Parking lamp circuit is normal.
NO >> Refer to [EXL-43, "Diagnosis Procedure"](#).

Diagnosis Procedure

INFOID:000000005460864

Regarding Wiring Diagram information, refer to [EXL-83, "Wiring Diagram"](#).

1. CHECK PARKING LAMP FUSES

1. Turn the ignition switch OFF.
2. Check that the following fuses are not open.

Unit	Location	Fuse No.	Capacity
Parking lamps (front)	IPDM E/R	46	10A
Parking lamps (rear)	IPDM E/R	47	10A

Is the fuse open?

- YES >> Repair the harness and replace the fuse.
NO >> GO TO 2.

2. CHECK TAIL LAMP RELAY OUTPUT (VOLTAGE)

CONSULT-III

1. Turn the ignition switch OFF.
2. Disconnect the front and rear combination lamp connectors.
3. Turn the ignition switch ON.
4. Select "EXTERNAL LAMPS" of IPDM E/R active test item.

PARKING LAMP CIRCUIT

[XENON TYPE]

< COMPONENT DIAGNOSIS >

5. With EXTERNAL LAMPS ON, check the voltage between the front combination lamp connector and ground.

(+)		Terminal	(-)	Voltage
Connector				
LH	E217	5	Ground	Battery voltage
RH	E224			

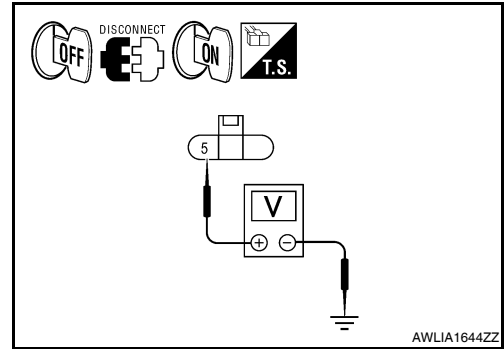

AWLIA1644ZZ

6. With EXTERNAL LAMPS ON, check the voltage between the rear combination lamp connector and ground.

(+)		Terminal	(-)	Voltage
Connector				
LH	B30	1	Ground	Battery voltage
RH	B45			

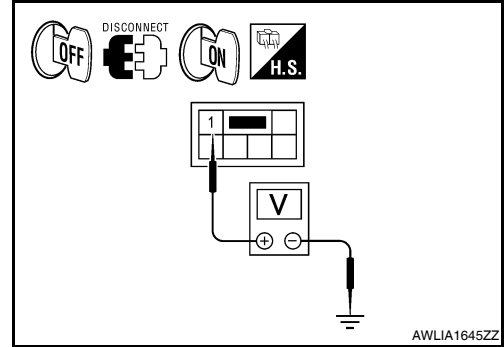

AWLIA1645ZZ

7. With EXTERNAL LAMP ON, check the voltage between the license plate lamp connector and ground.

(+)		Terminal	(-)	Voltage
Connector				
LH	T6	1	Ground	Battery voltage
RH	T8			

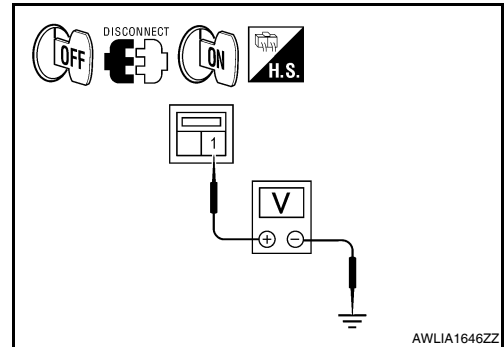

AWLIA1646ZZ

Is battery voltage present?

YES >> GO TO 4.

NO >> GO TO 3.

3. CHECK PARKING LAMP CIRCUIT (OPEN)

- Turn the ignition switch OFF.
- Disconnect IPDM E/R connector.
- Check continuity between the IPDM E/R harness connector (A) and the front combination lamp harness connector (B).

A		B		Continuity
Connector	Terminal	Connector	Terminal	
LH	E201	E217	5	Yes
RH		E224		

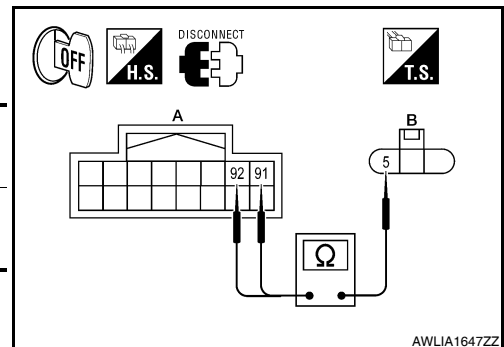

AWLIA1647ZZ

PARKING LAMP CIRCUIT

[XENON TYPE]

< COMPONENT DIAGNOSIS >

4. Check continuity between the IPDM E/R harness connector (A) and the rear combination lamp harness connector (B).

A			B		Continuity
Connector	Terminal		Connector	Terminal	
LH	E18	7	B30	1	Yes
RH			B45		

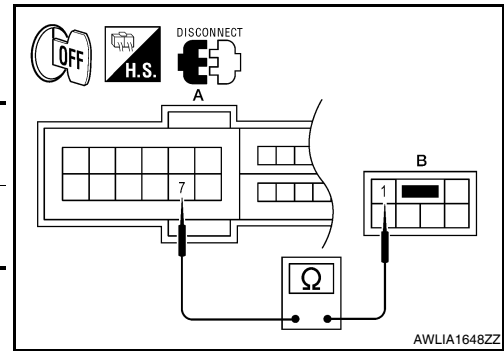

5. Check continuity between the IPDM E/R harness connector (A) and the license plate lamp harness connector (B).

A			B		Continuity
Connector	Terminal		Connector	Terminal	
LH	E18	7	T6	1	Yes
RH			T8		

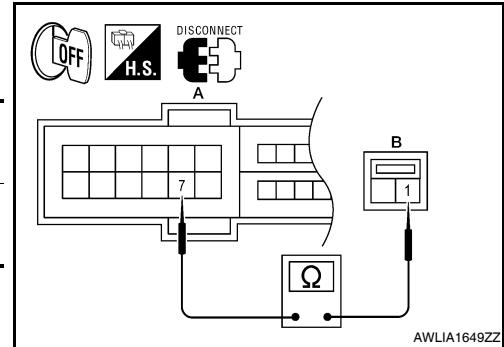

Does continuity exist?

YES >> Replace the IPDM E/R. Refer to [PCS-41. "Removal and Installation"](#).

NO >> Repair the harnesses or connectors.

4. CHECK PARKING LAMP GROUND CIRCUIT

1. Check continuity between the front combination lamp harness connector terminal and ground.

(+)			(-)	Continuity
Connector	Terminal			
LH	E217	6	Ground	Yes
RH				

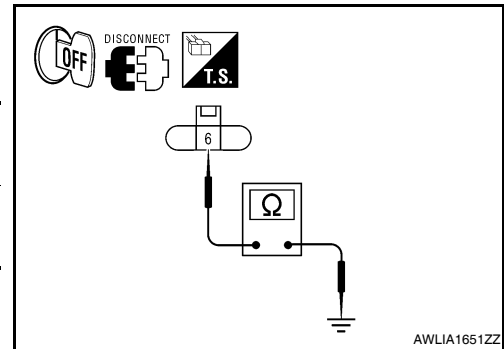

2. Check continuity between the rear combination lamp harness connector terminal and ground.

(+)			(-)	Continuity
Connector	Terminal			
LH	B30	4	Ground	Yes
RH				

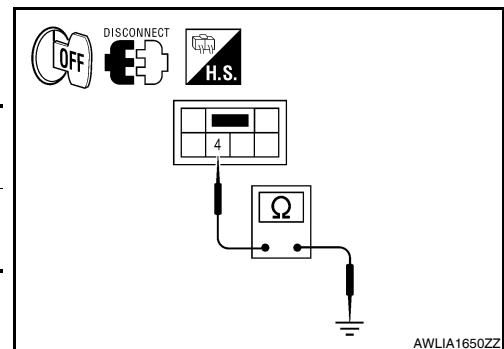

A
B
C
D
E
F
G
H
I
J
K
EXL
M
N
O
P

PARKING LAMP CIRCUIT

[XENON TYPE]

< COMPONENT DIAGNOSIS >

3. Check continuity between the license plate lamp harness connector terminal and ground.

(+)		Terminal	(-)	Continuity
Connector				
LH	T6	2	Ground	Yes
RH	T8			

Does continuity exist?

- YES >> Inspect the parking lamp bulb.
NO >> Repair the harness.

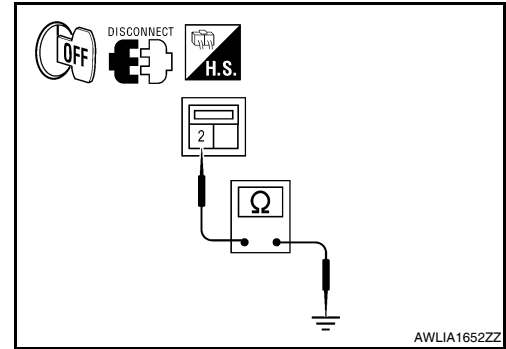

TURN SIGNAL LAMP CIRCUIT

< COMPONENT DIAGNOSIS >

[XENON TYPE]

TURN SIGNAL LAMP CIRCUIT

Description

INFOID:000000005460865

The BCM monitors inputs from the combination switch to determine when to activate the turn signals. The BCM outputs voltage direction to the left and right turn signals during turn signal operation or both during hazard warning operation. The BCM sends a turn signal indicator request to the combination meter via the CAN communication lines.

The BCM performs the fast flasher operation (fail-safe) if any bulb or harness of the turn signal lamp circuit is open.

NOTE:

Turn signal lamp blinks at normal speed when using the hazard warning lamp.

Component Function Check

INFOID:000000005460866

1. CHECK TURN SIGNAL LAMP

CONSULT-III

1. Select "FLASHER" of BCM (FLASHER) active test item.
2. While operating the test item, check that the turn signal lamp blinks.

LH : Turn signal lamp LH blinking

RH : Turn signal lamp RH blinking

OFF : The turn signal lamp OFF

Does the turn signal lamp blink?

- YES >> Turn signal lamp circuit is normal.
NO >> Refer to [EXL-47, "Diagnosis Procedure"](#).

Diagnosis Procedure

INFOID:000000005460867

Regarding Wiring Diagram information, refer to [EXL-75, "Wiring Diagram"](#).

1. CHECK TURN SIGNAL LAMP BULB

Check the applicable lamp bulb to be sure the proper bulb standard is in use and the bulb is not open.

Is the bulb OK?

- YES >> GO TO 2.
NO >> Replace the bulb.

2. CHECK TURN SIGNAL LAMP OUTPUT VOLTAGE

While operating the turn signal switch, check the voltage between the BCM harness connector and the ground.

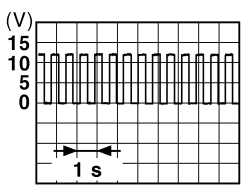
(+)		Terminal	(-)	Voltage
Connector				
RH	M17	17	Ground	 PKID0926E
LH	M17	18		

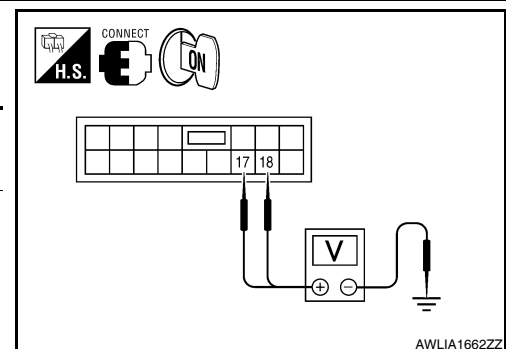

Is the measurement value normal?

- YES >> GO TO 3.
NO >> Replace BCM. Refer to [BCS-87, "Removal and Installation"](#).

TURN SIGNAL LAMP CIRCUIT

< COMPONENT DIAGNOSIS >

[XENON TYPE]

3. CHECK TURN SIGNAL LAMP CIRCUIT FOR OPEN

1. Turn the ignition switch OFF.
2. Disconnect BCM connector, front combination lamp connector, door mirror connector (with turn signal in mirror) and rear combination lamp connector.
3. Check continuity between the BCM harness connector (A) and the front combination lamp connector (B).

A		B		Continuity
Connector	Terminal	Connector	Terminal	
LH	M17	18	E217	Yes
RH		17	E224	

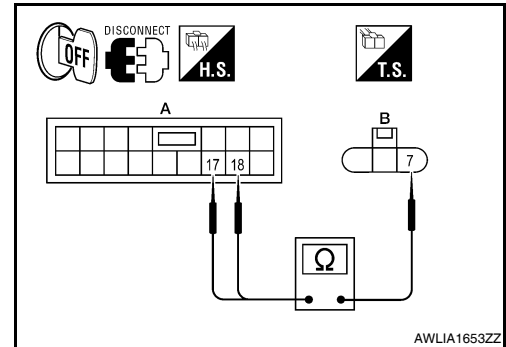

4. Check continuity between the BCM harness connector (A) and the rear combination lamp harness connector (B).

A		B		Continuity
Connector	Terminal	Connector	Terminal	
LH	M17	18	B30	Yes
RH		17	B45	

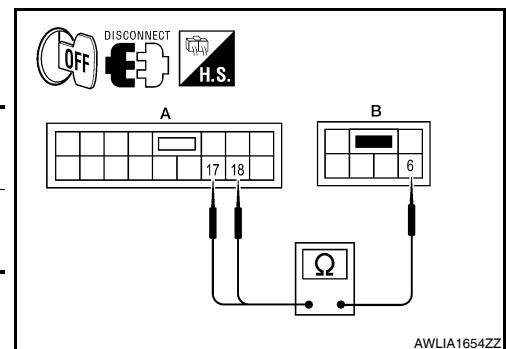

5. Check continuity between the BCM harness connector (A) and the door mirror connector (B) (if equipped with turn signal in mirror).

A		B		Continuity
Connector	Terminal	Connector	Terminal	
LH	M17	D4	8	Yes
RH		D107		

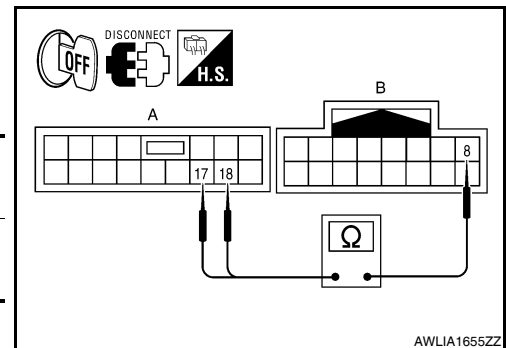

Does continuity exist?

YES >> GO TO 4.

NO >> Repair the harnesses or connectors.

4. CHECK TURN SIGNAL LAMP SHORT CIRCUIT

Check continuity between the BCM harness connector and ground.

Connector	Terminal	—	Continuity
LH	M17	18	No
RH		17	

Does continuity exist?

YES >> Repair the harnesses or connectors.

NO >> GO TO 5.

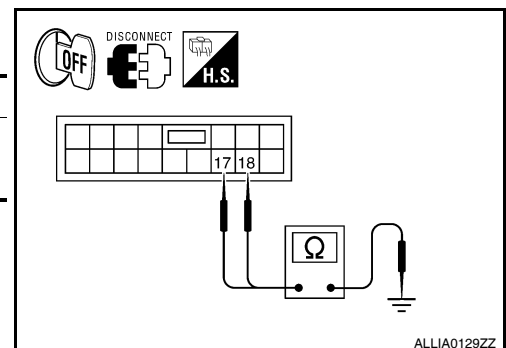

5. CHECK TURN SIGNAL LAMP GROUND CIRCUIT

TURN SIGNAL LAMP CIRCUIT

[XENON TYPE]

< COMPONENT DIAGNOSIS >

1. Check continuity between the front combination lamp and ground.

Connector		Terminal	—	Continuity
LH	E217	6	Ground	Yes
RH	E224			

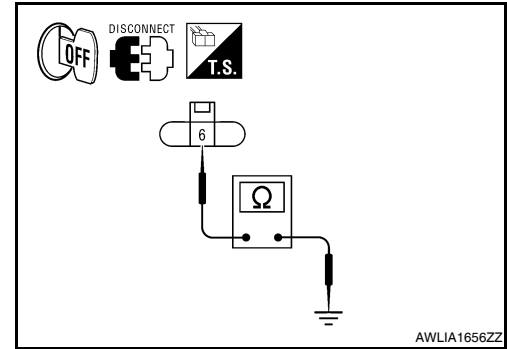

2. Check continuity between the rear combination lamp and ground.

Connector		Terminal	—	Continuity
LH	B30	4	Ground	Yes
RH	B45			

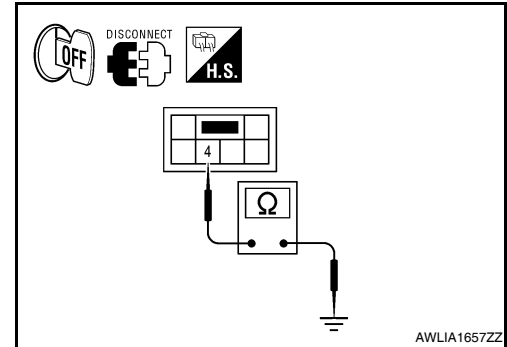

3. Check continuity between the door mirror and ground (if equipped with turn signal in mirror).

Connector		Terminal	—	Continuity
LH	D4	8	Ground	Yes
RH	D107			

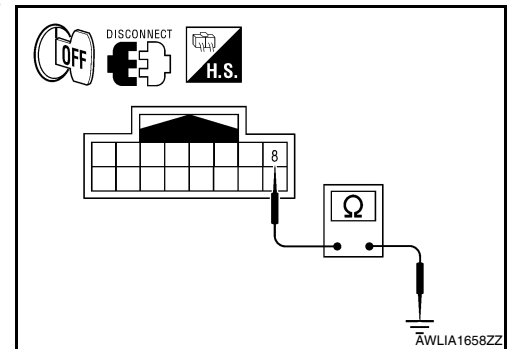

Does continuity exist?

- YES >> Replace the front combination lamp, the rear combination lamp or door mirror (if equipped with turn signal in mirror).
- NO >> Repair the harnesses or connectors.

A
B
C
D
E
F
G
H
I
J
K
EXL
M
N
O
P

OPTICAL SENSOR

[XENON TYPE]

< COMPONENT DIAGNOSIS >

OPTICAL SENSOR

Description

INFOID:000000005460868

The optical sensor converts the outside brightness (lux) to voltage and transmits the optical sensor signal to the BCM.

Component Function Check

INFOID:000000005460869

1.CHECK OPTICAL SENSOR SIGNAL BY CONSULT-III

CONSULT-III

1. Turn the ignition switch ON.
2. Select "OPTICAL SENSOR" of BCM (HEAD LAMP) DATA MONITOR item.
3. Turn the lighting switch to AUTO.
4. While the auto light system is operating, check the monitor status.

Monitor item	Condition	Voltage
OPTICAL SENSOR	When illuminating	3.1V or more *
	When shutting off light	0.6V or less

*: Illuminates the optical sensor. The value may be less than the standard value if brightness is weak.

Is the item status normal?

- YES >> Optical sensor is normal.
NO >> Refer to [EXL-50. "Diagnosis Procedure"](#).

Diagnosis Procedure

INFOID:000000005460870

Regarding Wiring Diagram information, refer to [EXL-65. "Wiring Diagram"](#).

1.CHECK OPTICAL SENSOR POWER SUPPLY INPUT

1. Turn the ignition switch ON.
2. Turn the lighting switch to AUTO.
3. Check the voltage between the optical sensor harness connector and ground.

(+)		(-)	Voltage
Connector	Terminal		
M66	1	Ground	5V

Is the voltage reading as specified?

- YES >> GO TO 2.
NO >> GO TO 4.

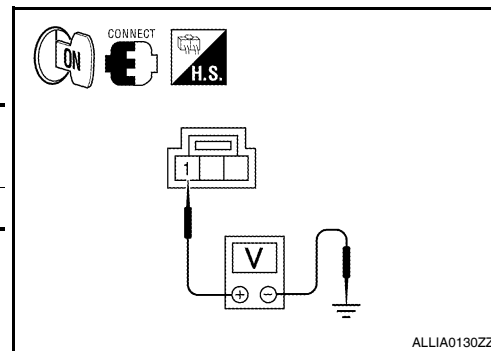

2.CHECK OPTICAL SENSOR GROUND INPUT

Check the voltage between the optical sensor harness connector and ground.

(+)		(-)	Voltage
Connector	Terminal		
M66	3	Ground	Less than 0.2V

Is the voltage reading as specified?

- YES >> GO TO 3.
NO >> GO TO 6.

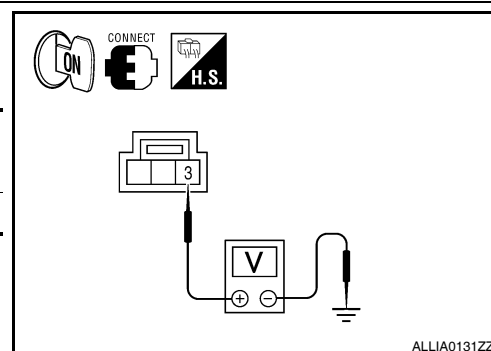

OPTICAL SENSOR

< COMPONENT DIAGNOSIS >

[XENON TYPE]

3. CHECK OPTICAL SENSOR SIGNAL OUTPUT

With the auto light system operating, check voltage between the optical sensor harness connector and ground.

(+)		(-)	Condition	Voltage
Connector	Terminal			
M66	2	Ground	When illuminating	3.1V or more *
			When shutting off light	0.6V or less

*: Illuminate the optical sensor. The value may be less than the standard if brightness is weak.

Is the voltage reading as specified?

YES >> GO TO 7.

NO >> Replace the optical sensor. Refer to [EXL-170, "Removal and Installation"](#).

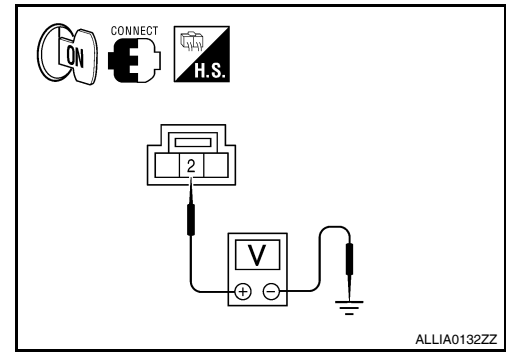

4. CHECK OPTICAL SENSOR POWER SUPPLY FOR OPEN CIRCUIT

1. Turn the ignition switch OFF.
2. Disconnect the optical sensor connector and BCM connector.
3. Check continuity between the optical sensor harness connector and the BCM harness connector.

A		B		Continuity
Connector	Terminal	Connector	Terminal	
M66	1	M18	46	Yes

Does continuity exist?

YES >> GO TO 5.

NO >> Repair the harnesses or connectors.

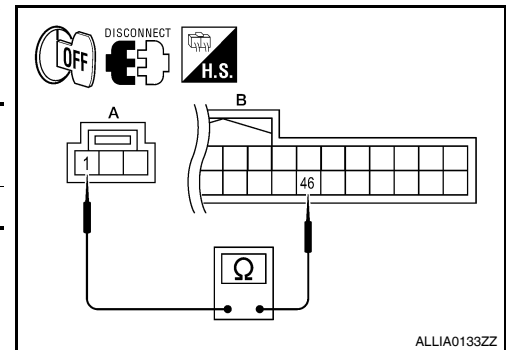

5. CHECK OPTICAL SENSOR POWER SUPPLY FOR SHORT CIRCUIT

Check the continuity between the optical sensor harness connector and the ground.

Connector	Terminal	—	Continuity
M66	1	Ground	No

Does continuity exist?

YES >> Repair the harnesses or connectors.

NO >> Replace BCM. Refer to [BCS-87, "Removal and Installation"](#).

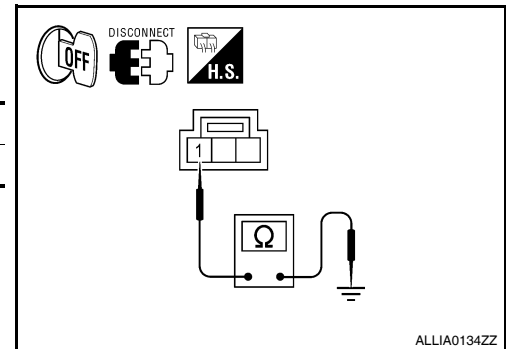

6. CHECK OPTICAL SENSOR GROUND FOR OPEN CIRCUIT

1. Turn the ignition switch OFF.
2. Disconnect the optical sensor connector and BCM connector.
3. Check continuity between the optical sensor harness connector and the BCM harness connector.

A		B		Continuity
Connector	Terminal	Connector	Terminal	
M66	3	M18	45	Yes

Does continuity exist?

YES >> Replace BCM. Refer to [BCS-87, "Removal and Installation"](#).

NO >> Repair the harnesses or connectors.

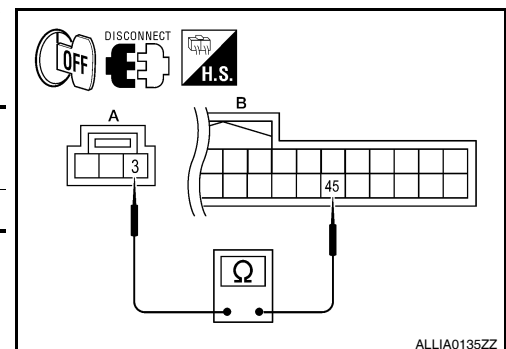

OPTICAL SENSOR

[XENON TYPE]

< COMPONENT DIAGNOSIS >

7. CHECK OPTICAL SENSOR SIGNAL FOR OPEN CIRCUIT

1. Turn the ignition switch OFF.
2. Disconnect the optical sensor connector and BCM connector.
3. Check continuity between the optical sensor harness connector and the BCM harness connector.

A		B		Continuity
Connector	Terminal	Connector	Terminal	
M66	2	M18	21	Yes

Does continuity exist?

YES >> GO TO 8.

NO >> Repair the harnesses or connectors.

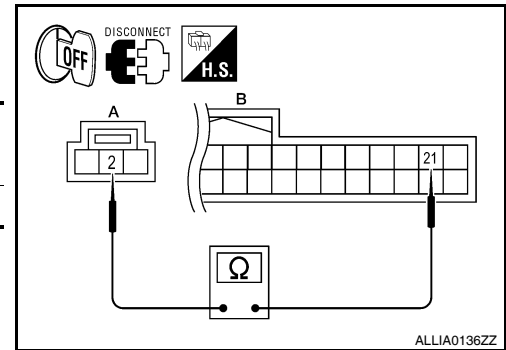

ALLIA0136ZZ

8. CHECK OPTICAL SENSOR SIGNAL FOR SHORT CIRCUIT

Check the continuity between the optical sensor harness connector and ground.

Connector	Terminal	—	Continuity
M66	2	Ground	No

Does continuity exist?

YES >> Repair the harnesses or connectors.

NO >> Replace BCM. Refer to [BCS-87. "Removal and Installation"](#).

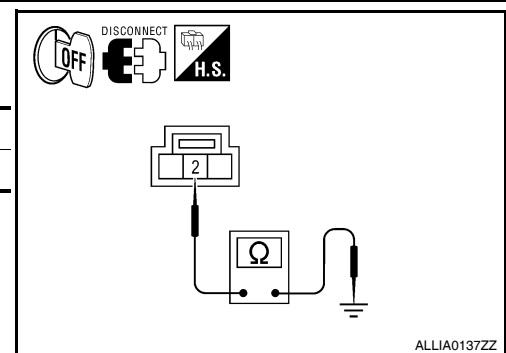

ALLIA0137ZZ

HEADLAMP

< COMPONENT DIAGNOSIS >

[XENON TYPE]

HEADLAMP

Wiring Diagram

INFOID:000000005460871

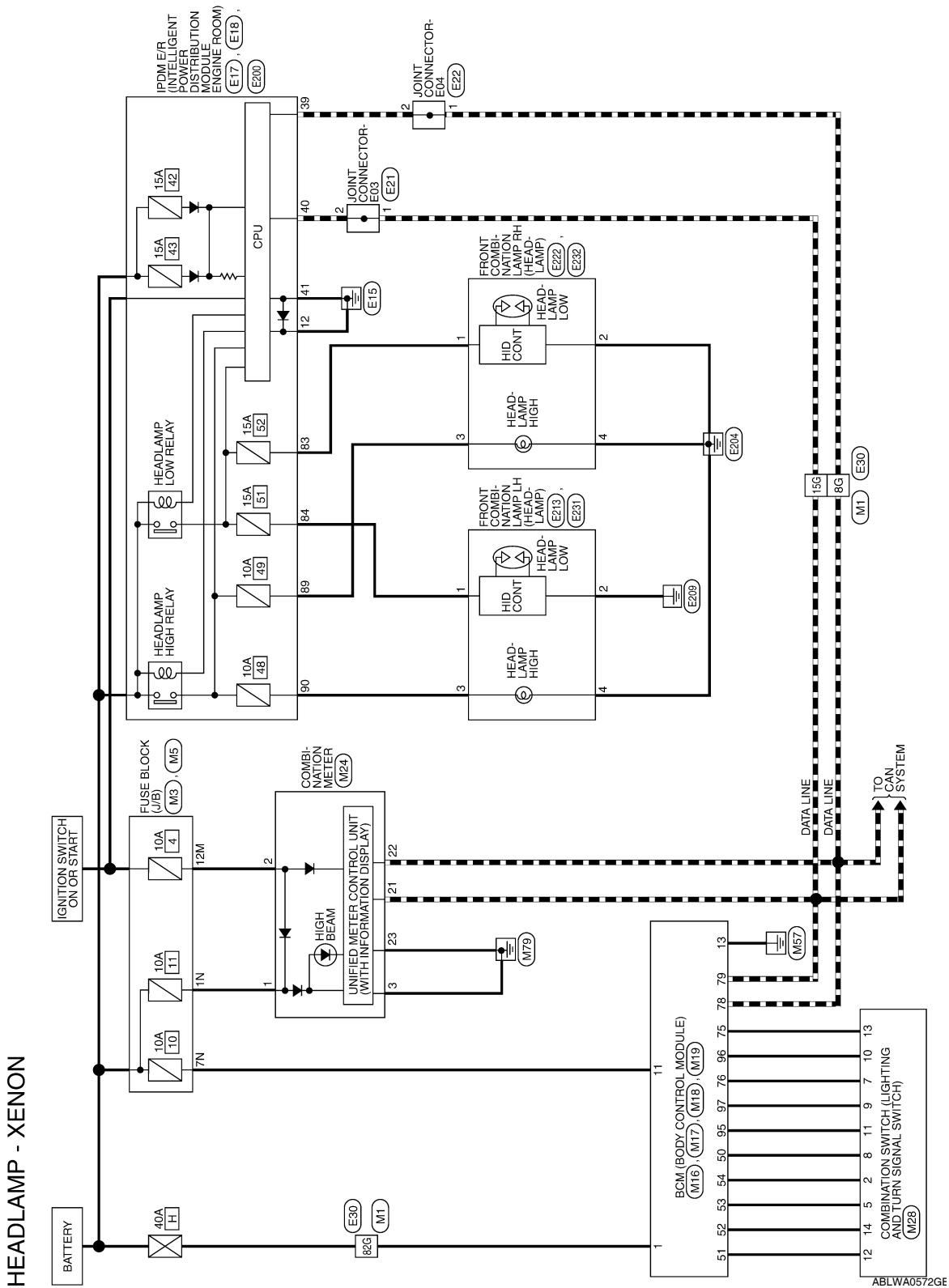

A
B
C
D
E
F
G
H
I
J
K
L
M
N
O
P

EXL

HEADLAMP

< COMPONENT DIAGNOSIS >

[XENON TYPE]

HEADLAMP CONNECTORS - XENON

Connector No.	M1
Connector Name	WIRE TO WIRE
Connector Color	WHITE

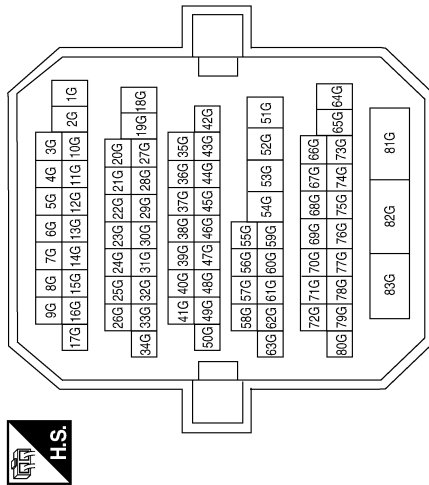

Terminal No.	Color of Wire	Signal Name
8G	P	-
15G	L	-
82G	W/B	-

Connector No.	M3
Connector Name	FUSE BLOCK (J/B)
Connector Color	WHITE

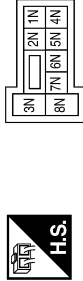

Terminal No.	Color of Wire	Signal Name
1N	W/L	-
7N	Y/R	-

Connector No.	M5
Connector Name	FUSE BLOCK (J/B)
Connector Color	WHITE



Terminal No.	Color of Wire	Signal Name
12M	O	-

Connector No.	M16
Connector Name	BCM (BODY CONTROL MODULE)
Connector Color	BLACK



Terminal No.	Color of Wire	Signal Name
1	W/B	BATT (F/L)

Connector No.	M17
Connector Name	BCM (BODY CONTROL MODULE)
Connector Color	WHITE

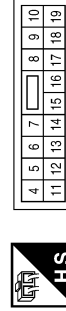

Terminal No.	Color of Wire	Signal Name
11	Y/R	BAT BCM FUSE
13	B	GND1

HEADLAMP

< COMPONENT DIAGNOSIS >

[XENON TYPE]

Connector No.	M24
Connector Name	COMBINATION METER
Connector Color	WHITE



1	2	3	4	5	6	7	8	9	10	11	12	13	14	15	16	17	18	19	20
21	22	23	24	25	26	27	28	29	30	31	32	33	34	35	36	37	38	39	40

Terminal No.	Color of Wire	Signal Name
1	W/L	BAT
2	O	IGN
3	B	GND (POWER)
21	L	CAN-H
22	P	CAN-L
23	B	GND (CIRCUIT)

Connector No.	M19
Connector Name	BCM (BODY CONTROL MODULE)
Connector Color	BLACK



79	78	77	76	75	74	73	72	71	70	69	68	67	66	65	64	63	62	61	60
99	98	97	96	95	94	93	92	91	90	89	88	87	86	85	84	83	82	81	80

Terminal No.	Color of Wire	Signal Name
75	R/Y	INPUT 5
76	R/G	INPUT 3
78	P	CAN-L
79	L	CAN-H
95	R/W	INPUT 1
96	P/B	INPUT 4
97	R/B	INPUT 2

Connector No.	M18
Connector Name	BCM (BODY CONTROL MODULE)
Connector Color	GREEN



39	38	37	36	35	34	33	32	31	30	29	28	27	26	25	24	23	22	21	20
59	58	57	56	55	54	53	52	51	50	49	48	47	46	45	44	43	42	41	40

Terminal No.	Color of Wire	Signal Name
50	LG/B	OUTPUT 5
51	L/W	OUTPUT 1
52	G/B	OUTPUT 2
53	LG/R	OUTPUT 3
54	G/Y	OUTPUT 4

Connector No.	E17
Connector Name	IPDM E/R (INTELLIGENT POWER DISTRIBUTION MODULE ENGINE ROOM)
Connector Color	WHITE



42	41	40	39
46	45	44	43

Terminal No.	Color of Wire	Signal Name
39	P	CAN-L
40	L	CAN-H
41	B	GND (SIGNAL)

Terminal No.	Color of Wire	Signal Name
2	G/Y	OUTPUT 4
5	LG/R	OUTPUT 3
7	R/G	INPUT 3
8	LG/B	OUTPUT 5
9	R/B	INPUT 2
10	P/B	INPUT 4
11	R/W	INPUT 1
12	L/W	OUTPUT 1
13	R/Y	INPUT 5
14	G/B	OUTPUT 2

Connector No.	M28
Connector Name	COMBINATION SWITCH
Connector Color	WHITE



1	2	3	4	5	6		
7	8	9	10	11	12	13	14

ABLIA1706GB

A
B
C
D
E
F
G
H
I
J
K
L
M
N
O
P

EXL

HEADLAMP

< COMPONENT DIAGNOSIS >

[XENON TYPE]

Connector No.	E21
Connector Name	JOINT CONNECTOR-E03
Connector Color	WHITE



Terminal No.	Color of Wire	Signal Name
1	L	-
2	L	-

Terminal No.	Color of Wire	Signal Name
12	B	GND (POWER)

Connector No.	E18
Connector Name	IPDM E/R (INTELLIGENT POWER DISTRIBUTION MODULE ENGINE ROOM)
Connector Color	WHITE

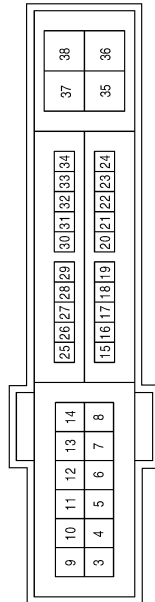

Terminal No.	Color of Wire	Signal Name
8G	P	-
15G	L	-
82G	LG	-

Connector No.	E30
Connector Name	WIRE TO WIRE
Connector Color	WHITE

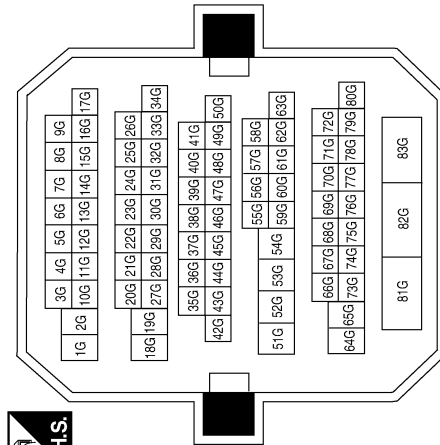

Connector No.	E22
Connector Name	JOINT CONNECTOR-E04
Connector Color	WHITE

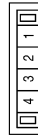

Terminal No.	Color of Wire	Signal Name
1	P	-
2	P	-

ABLIA1210GB

HEADLAMP

< COMPONENT DIAGNOSIS >

[XENON TYPE]

Connector No.	E222
Connector Name	FRONT COMBINATION LAMP RH (WITHOUT DAYTIME LIGHT SYSTEM)
Connector Color	BLACK



Terminal No.	Color of Wire	Signal Name
3	L/W	-
4	B	-

Connector No.	E213
Connector Name	FRONT COMBINATION LAMP LH
Connector Color	BLACK



Terminal No.	Color of Wire	Signal Name
3	G	-
4	B	-

Connector No.	E200
Connector Name	IPDM E/R (INTELLIGENT POWER DISTRIBUTION MODULE ENGINE ROOM)
Connector Color	WHITE

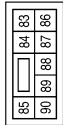

Terminal No.	Color of Wire	Signal Name
83	R/Y	HEADLAMP LO RH
84	L	HEADLAMP LO LH
89	L/W	HEADLAMP HI RH
90	G	HEADLAMP HI LH

Connector No.	E232
Connector Name	FRONT COMBINATION LAMP RH (WITH XENON HEADLAMP SYSTEM)
Connector Color	GRAY



Terminal No.	Color of Wire	Signal Name
1	R/Y	-
2	B	-

Connector No.	E231
Connector Name	FRONT COMBINATION LAMP LH (WITH XENON HEADLAMP SYSTEM)
Connector Color	GRAY



Terminal No.	Color of Wire	Signal Name
1	L	-
2	B	-

ABLIA0491GB

A
B
C
D
E
F
G
H
I
J
K
L
M
N
O
P

EXL

DAYTIME RUNNING LIGHT SYSTEM

< COMPONENT DIAGNOSIS >

[XENON TYPE]

DAYTIME RUNNING LIGHT SYSTEM

Wiring Diagram

INFOID:000000005460872

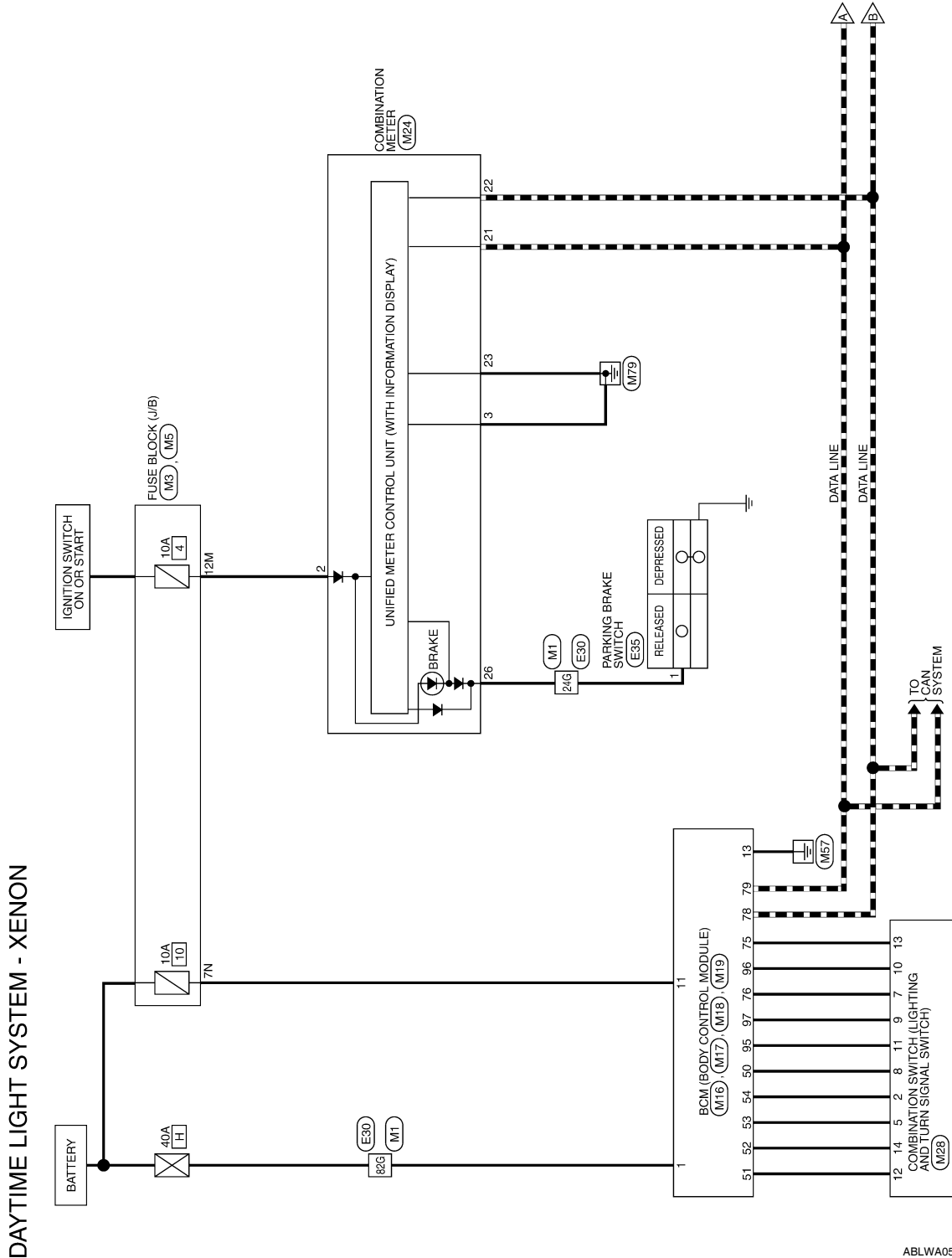

ABLWA0573GE

DAYTIME RUNNING LIGHT SYSTEM

< COMPONENT DIAGNOSIS >

[XENON TYPE]

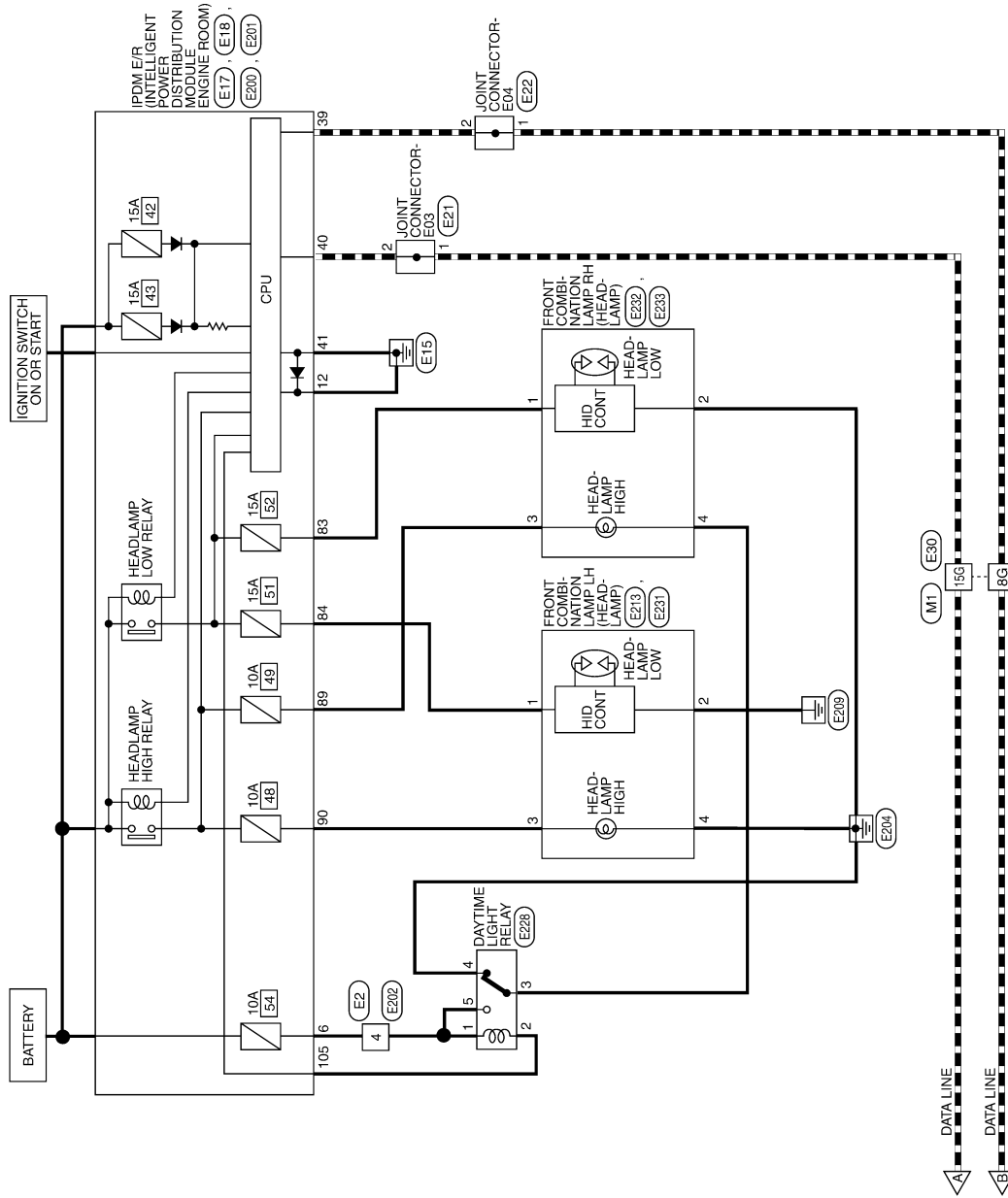

A
B
C
D
E
F
G
H
I
J
K
EXL
M
N
O
P

ABLWA0574GE

DAYTIME RUNNING LIGHT SYSTEM

< COMPONENT DIAGNOSIS >

[XENON TYPE]

DAYTIME LIGHT SYSTEM CONNECTORS - XENON

Connector No.	M1
Connector Name	WIRE TO WIRE
Connector Color	WHITE

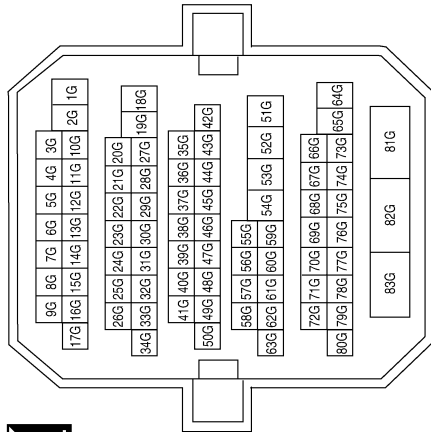

Terminal No.	Color of Wire	Signal Name
8G	P	-
15G	L	-
24G	G/R	-
82G	W/B	-

Connector No.	M3
Connector Name	FUSE BLOCK (J/B)
Connector Color	WHITE

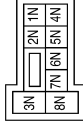

Terminal No.	Color of Wire	Signal Name
7N	Y/R	-

Connector No.	M5
Connector Name	FUSE BLOCK (J/B)
Connector Color	WHITE

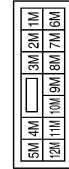

Terminal No.	Color of Wire	Signal Name
12M	O	-

Connector No.	M16
Connector Name	BCM (BODY CONTROL MODULE)
Connector Color	BLACK



Terminal No.	Color of Wire	Signal Name
1	W/B	BATT (F/L)

Connector No.	M17
Connector Name	BCM (BODY CONTROL MODULE)
Connector Color	WHITE

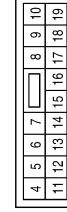

Terminal No.	Color of Wire	Signal Name
11	Y/R	BAT BCM FUSE
13	B	GND1

DAYTIME RUNNING LIGHT SYSTEM

< COMPONENT DIAGNOSIS >

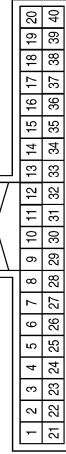

[XENON TYPE]

Connector No.	M24
Connector Name	COMBINATION METER
Connector Color	WHITE

Terminal No.	Color of Wire	Signal Name
2	O	IGN
3	B	GND (POWER)
21	L	CAN-H
22	P	CAN-L
23	B	GND(CIRCUIT)
26	G/R	PKB

Connector No.	M19
Connector Name	BCM (BODY CONTROL MODULE)
Connector Color	BLACK

Terminal No.	Color of Wire	Signal Name
75	R/Y	INPUT 5
76	R/G	INPUT 3
78	P	CAN-L
79	L	CAN-H
95	R/W	INPUT 1
96	P/B	INPUT 4
97	R/B	INPUT 2

Connector No.	M18
Connector Name	BCM (BODY CONTROL MODULE)
Connector Color	GREEN

Terminal No.	Color of Wire	Signal Name
50	LG/B	OUTPUT 5
51	L/W	OUTPUT 1
52	G/B	OUTPUT 2
53	LG/R	OUTPUT 3
54	G/Y	OUTPUT 4

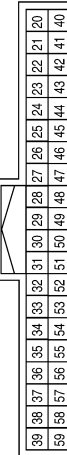
Connector No.	E2
Connector Name	WIRE TO WIRE
Connector Color	WHITE



Terminal No.	Color of Wire	Signal Name
4	L	-

Terminal No.	Color of Wire	Signal Name
9	R/B	INPUT 2
10	P/B	INPUT 4
11	R/W	INPUT 1
12	L/W	OUTPUT 1
13	R/Y	INPUT 5
14	G/B	OUTPUT 2

Connector No.	M28
Connector Name	COMBINATION SWITCH
Connector Color	WHITE



Terminal No.	Color of Wire	Signal Name
2	G/Y	OUTPUT 4
5	LG/R	OUTPUT 3
7	R/G	INPUT 3
8	LG/B	OUTPUT 5

ABLIA1708GB

A
B
C
D
E
F
G
H
I
J
K
L
M
N
O
P

EXL

DAYTIME RUNNING LIGHT SYSTEM

< COMPONENT DIAGNOSIS >

[XENON TYPE]

Terminal No.	Color of Wire	Signal Name
6	L	DTRL
12	B	GND (POWER)

Connector No.	E18
Connector Name	IPDM E/R (INTELLIGENT POWER DISTRIBUTION MODULE ENGINE ROOM)
Connector Color	WHITE

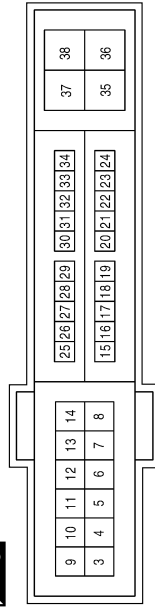

Connector No.	E17
Connector Name	IPDM E/R (INTELLIGENT POWER DISTRIBUTION MODULE ENGINE ROOM)
Connector Color	WHITE

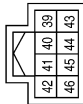

Terminal No.	Color of Wire	Signal Name
39	P	CAN-L
40	L	CAN-H
41	B	GND (SIGNAL)

Connector No.	E22
Connector Name	JOINT CONNECTOR-E04
Connector Color	WHITE



Terminal No.	Color of Wire	Signal Name
1	P	-
2	P	-

Connector No.	E21
Connector Name	JOINT CONNECTOR-E03
Connector Color	WHITE



Terminal No.	Color of Wire	Signal Name
1	L	-
2	L	-

ABLIA1709GB

DAYTIME RUNNING LIGHT SYSTEM

< COMPONENT DIAGNOSIS >

[XENON TYPE]

Connector No.	E35
Connector Name	PARKING BRAKE SWITCH
Connector Color	BLACK

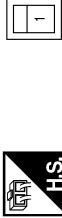

Terminal No.	Color of Wire	Signal Name
1	P	-

Terminal No.	Color of Wire	Signal Name
8G	P	-
15G	L	-
24G	P	-
82G	LG	-

Connector No.	E30
Connector Name	WIRE TO WIRE
Connector Color	WHITE

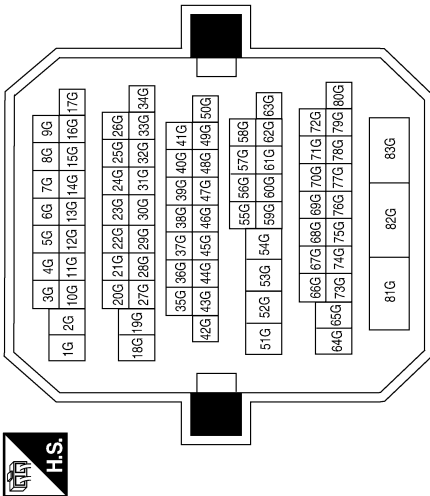

Connector No.	E202
Connector Name	WIRE TO WIRE
Connector Color	WHITE



Terminal No.	Color of Wire	Signal Name
4	SB	-

Connector No.	E201
Connector Name	IPDM E/R (INTELLIGENT POWER DISTRIBUTION MODULE ENGINE ROOM)
Connector Color	WHITE

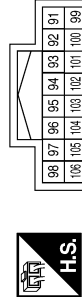

Terminal No.	Color of Wire	Signal Name
105	V	DTRL RLY

Connector No.	E200
Connector Name	IPDM E/R (INTELLIGENT POWER DISTRIBUTION MODULE ENGINE ROOM)
Connector Color	WHITE



Terminal No.	Color of Wire	Signal Name
83	R/Y	HEADLAMP LO RH
84	L	HEADLAMP LO LH
89	L/W	HEADLAMP HI RH
90	G	HEADLAMP HI LH

ABLIA1710GB

A
B
C
D
E
F
G
H
I
J
K
L
M
N
O
P

EXL

DAYTIME RUNNING LIGHT SYSTEM

< COMPONENT DIAGNOSIS >

[XENON TYPE]

Connector No.	E231
Connector Name	FRONT COMBINATION LAMP LH (WITH XENON HEADLAMP SYSTEM)
Connector Color	GRAY



Terminal No.	Color of Wire	Signal Name
1	L	-
2	B	-

Connector No.	E228
Connector Name	DAYTIME LIGHT RELAY
Connector Color	BLACK



Terminal No.	Color of Wire	Signal Name
1	SB	-
2	V	-
3	GR/R	-
4	B	-
5	SB	-

Connector No.	E213
Connector Name	FRONT COMBINATION LAMP LH
Connector Color	BLACK



Terminal No.	Color of Wire	Signal Name
3	G	-
4	B	-

Connector No.	E233
Connector Name	FRONT COMBINATION LAMP RH (WITH DAYTIME LIGHT SYSTEM)
Connector Color	BLACK



Terminal No.	Color of Wire	Signal Name
3	L/W	-
4	GR/R	-

Connector No.	E232
Connector Name	FRONT COMBINATION LAMP RH (WITH XENON HEADLAMP SYSTEM)
Connector Color	GRAY



Terminal No.	Color of Wire	Signal Name
1	R/Y	-
2	B	-

ABLIA1711GB

AUTO LIGHT SYSTEM

< COMPONENT DIAGNOSIS >

[XENON TYPE]

AUTO LIGHT SYSTEM

Wiring Diagram

INFOID:000000005460873

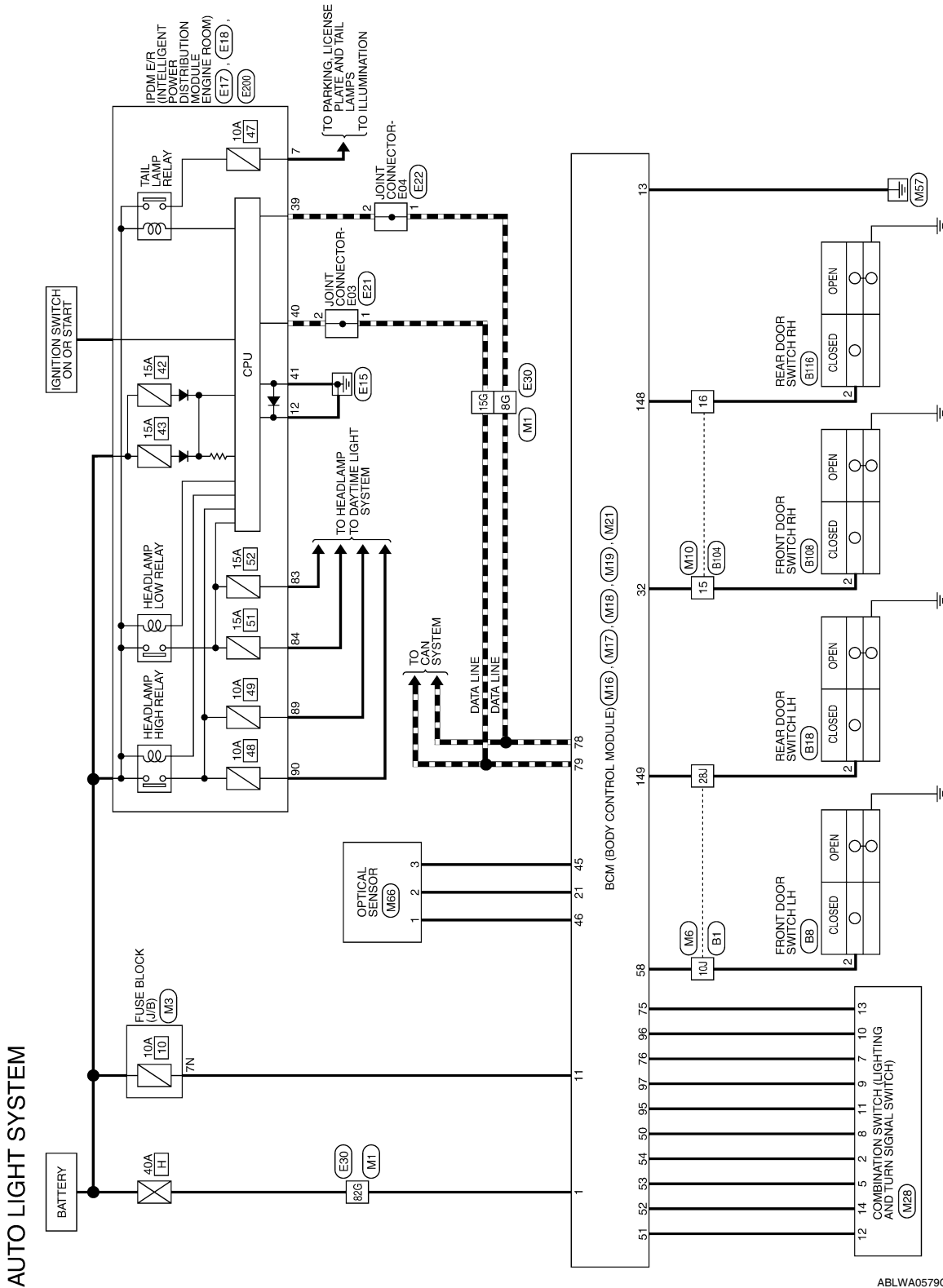

ABLWA0579GE

A
B
C
D
E
F
G
H
I
J
K
EXL
M
N
O
P

AUTO LIGHT SYSTEM CONNECTORS

Connector No.	M1
Connector Name	WIRE TO WIRE
Connector Color	WHITE

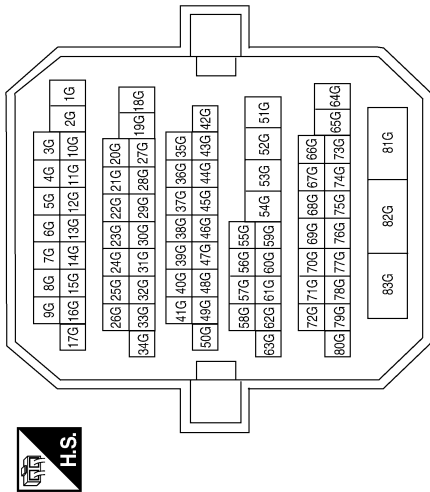

Terminal No.	Color of Wire	Signal Name
8G	P	-
15G	L	-
82G	W/B	-

Connector No.	M10
Connector Name	WIRE TO WIRE
Connector Color	WHITE

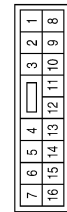

Terminal No.	Color of Wire	Signal Name
15	R/B	-
16	R/W	-

Connector No.	M3
Connector Name	FUSE BLOCK (J/B)
Connector Color	WHITE

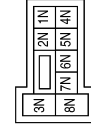

Terminal No.	Color of Wire	Signal Name
7N	Y/R	-

Connector No.	M6
Connector Name	WIRE TO WIRE
Connector Color	WHITE

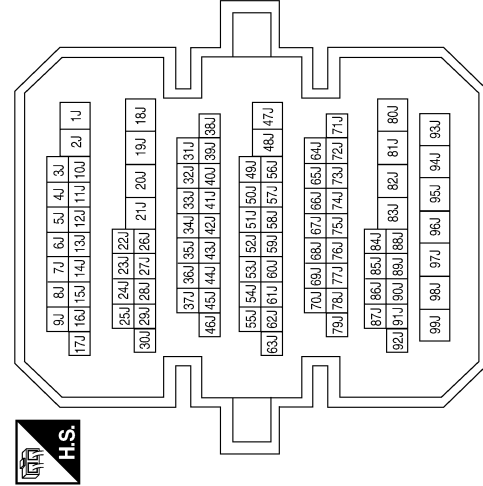

Terminal No.	Color of Wire	Signal Name
10J	SB	-
28J	R/B	-

Connector No.	M17
Connector Name	BCM (BODY CONTROL MODULE)
Connector Color	WHITE

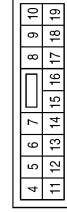

Terminal No.	Color of Wire	Signal Name
11	Y/R	BAT BCM FUSE
13	B	GND1

Connector No.	M16
Connector Name	BCM (BODY CONTROL MODULE)
Connector Color	BLACK



Terminal No.	Color of Wire	Signal Name
1	W/B	BATT (F/L)

AUTO LIGHT SYSTEM

< COMPONENT DIAGNOSIS >

[XENON TYPE]

Connector No.	M19
Connector Name	BCM (BODY CONTROL MODULE)
Connector Color	BLACK

79	78	77	76	75	74	73	72	71	70	69	68	67	66	65	64	63	62	61	60
99	98	97	96	95	94	93	92	91	90	89	88	87	86	85	84	83	82	81	80

Terminal No.	Color of Wire	Signal Name
21	P/B	A/L SIGNAL TYPE 1
32	R/B	AS DOOR SW 1
45	P	GND RF2 A/L
46	V/W	A/L POWER SUPPLY 5V
50	LG/B	OUTPUT 5
51	L/W	OUTPUT 1
52	G/B	OUTPUT 2
53	LG/R	OUTPUT 3
54	G/Y	OUTPUT 4
58	SB	DR DOOR SW

Connector No.	M18
Connector Name	BCM (BODY CONTROL MODULE)
Connector Color	GREEN

39	38	37	36	35	34	33	32	31	30	29	28	27	26	25	24	23	22	21	20
59	58	57	56	55	54	53	52	51	50	49	48	47	46	45	44	43	42	41	40

Terminal No.	Color of Wire	Signal Name
75	R/Y	INPUT 5
76	R/G	INPUT 3
78	P	CAN-L
79	L	CAN-H
95	R/W	INPUT 1
96	P/B	INPUT 4
97	R/B	INPUT 2

Terminal No.	Color of Wire	Signal Name
2	G/Y	OUTPUT 4
5	LG/R	OUTPUT 3
7	R/G	INPUT 3
8	LG/B	OUTPUT 5
9	R/B	INPUT 2
10	P/B	INPUT 4
11	R/W	INPUT 1
12	L/W	OUTPUT 1
13	R/Y	INPUT 5
14	G/B	OUTPUT 2

Connector No.	M28
Connector Name	COMBINATION SWITCH
Connector Color	WHITE

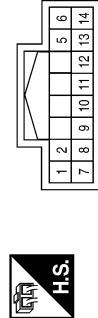

Connector No.	M21
Connector Name	BCM (BODY CONTROL MODULE)
Connector Color	GRAY

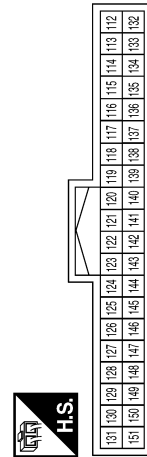

Terminal No.	Color of Wire	Signal Name
148	R/W	RR DOOR SW
149	R/B	RL DOOR SW

ABLIA1725GB

A
B
C
D
E
F
G
H
I
J
K
L
M
N
O
P

EXL

AUTO LIGHT SYSTEM

< COMPONENT DIAGNOSIS >

[XENON TYPE]

Connector No. M66	E18	E18
Connector Name OPTICAL SENSOR	Connector Name IPDM E/R (INTELLIGENT POWER DISTRIBUTION MODULE ENGINE ROOM)	IPDM E/R (INTELLIGENT POWER DISTRIBUTION MODULE ENGINE ROOM)
Connector Color WHITE	Connector Color WHITE	WHITE

Terminal No.	Color of Wire	Signal Name
1	V/W	POWER
2	P/B	OUTPUT
3	P	GND

Terminal No.	Color of Wire	Signal Name
9	GR	TAIL/ILLUMI
12	B	GND (POWER)

Connector No. E17	E17	E17
Connector Name IPDM E/R (INTELLIGENT POWER DISTRIBUTION MODULE ENGINE ROOM)	Connector Name IPDM E/R (INTELLIGENT POWER DISTRIBUTION MODULE ENGINE ROOM)	IPDM E/R (INTELLIGENT POWER DISTRIBUTION MODULE ENGINE ROOM)
Connector Color WHITE	Connector Color WHITE	WHITE

Terminal No.	Color of Wire	Signal Name
39	P	CAN-L
40	L	CAN-H
41	B	GND (SIGNAL)

Connector No. E21	E21	E21
Connector Name JOINT CONNECTOR-E03	Connector Name JOINT CONNECTOR-E04	JOINT CONNECTOR-E04
Connector Color WHITE	Connector Color WHITE	WHITE

Terminal No.	Color of Wire	Signal Name
1	L	-
2	L	-

Connector No. E22	E22	E22
Connector Name JOINT CONNECTOR-E04	Connector Name JOINT CONNECTOR-E04	JOINT CONNECTOR-E04
Connector Color WHITE	Connector Color WHITE	WHITE

Terminal No.	Color of Wire	Signal Name
1	P	-
2	P	-

Connector No. E23	E23	E23
Connector Name JOINT CONNECTOR-E03	Connector Name JOINT CONNECTOR-E03	JOINT CONNECTOR-E03
Connector Color WHITE	Connector Color WHITE	WHITE

Terminal No.	Color of Wire	Signal Name
1	L	-
2	L	-

Connector No. E24	E24	E24
Connector Name JOINT CONNECTOR-E03	Connector Name JOINT CONNECTOR-E03	JOINT CONNECTOR-E03
Connector Color WHITE	Connector Color WHITE	WHITE

Terminal No.	Color of Wire	Signal Name
1	L	-
2	L	-

ABLIA1212GB

AUTO LIGHT SYSTEM

< COMPONENT DIAGNOSIS >

[XENON TYPE]

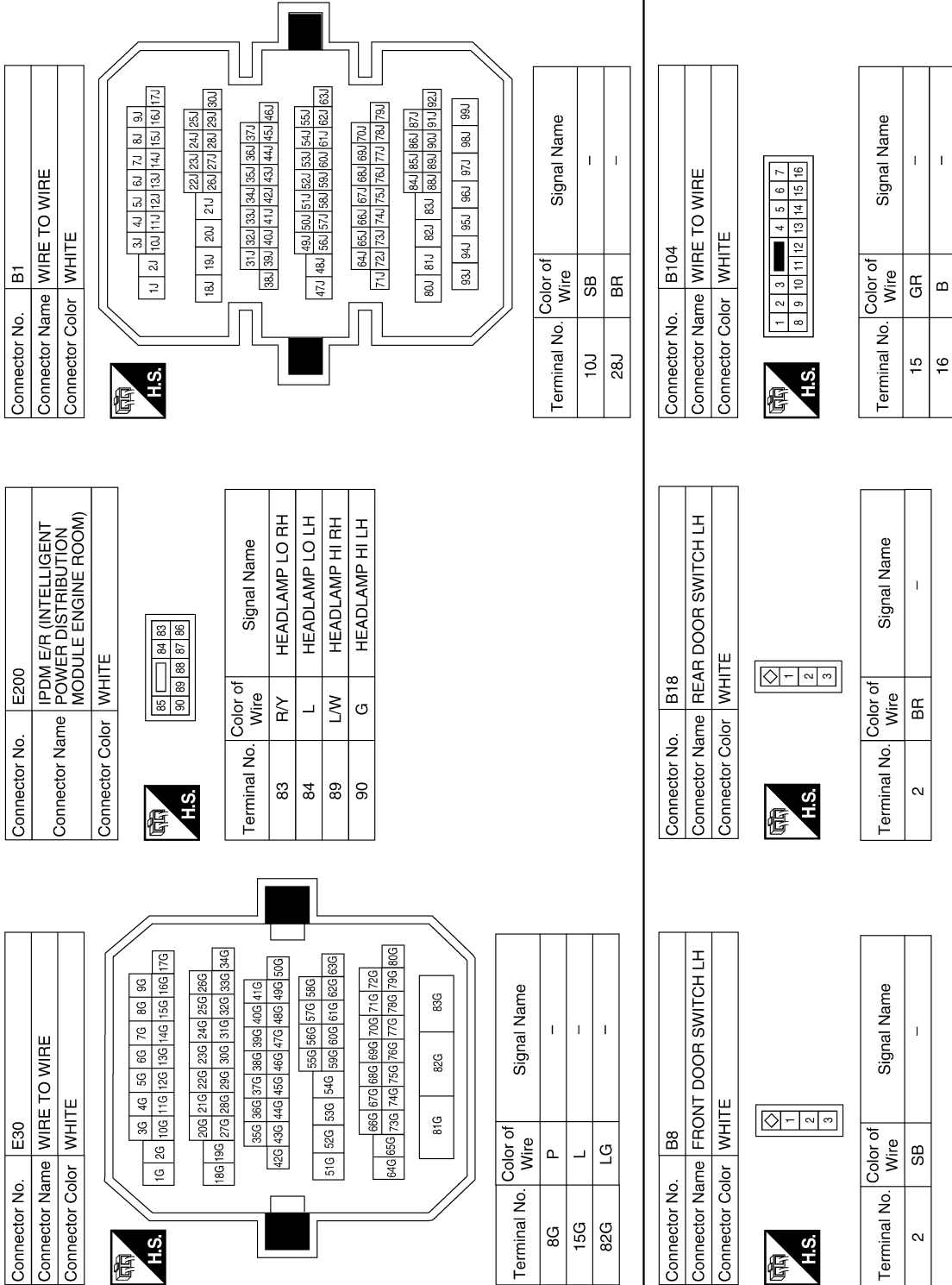

A
B
C
D
E
F
G
H
I
J
K
L
M
N
O
P

EXL

AUTO LIGHT SYSTEM

< COMPONENT DIAGNOSIS >

[XENON TYPE]

Connector No.	B116	
Connector Name	REAR DOOR SWITCH RH	
Connector Color	WHITE	



1
2
3

Terminal No.	Color of Wire	Signal Name
2	B	-

Connector No.	B108	
Connector Name	FRONT DOOR SWITCH RH	
Connector Color	WHITE	



1
2
3

Terminal No.	Color of Wire	Signal Name
2	GR	-

ABLIA0510GB

FRONT FOG LAMP SYSTEM

< COMPONENT DIAGNOSIS >

[XENON TYPE]

FRONT FOG LAMP SYSTEM

Wiring Diagram

INFOID:000000005460874

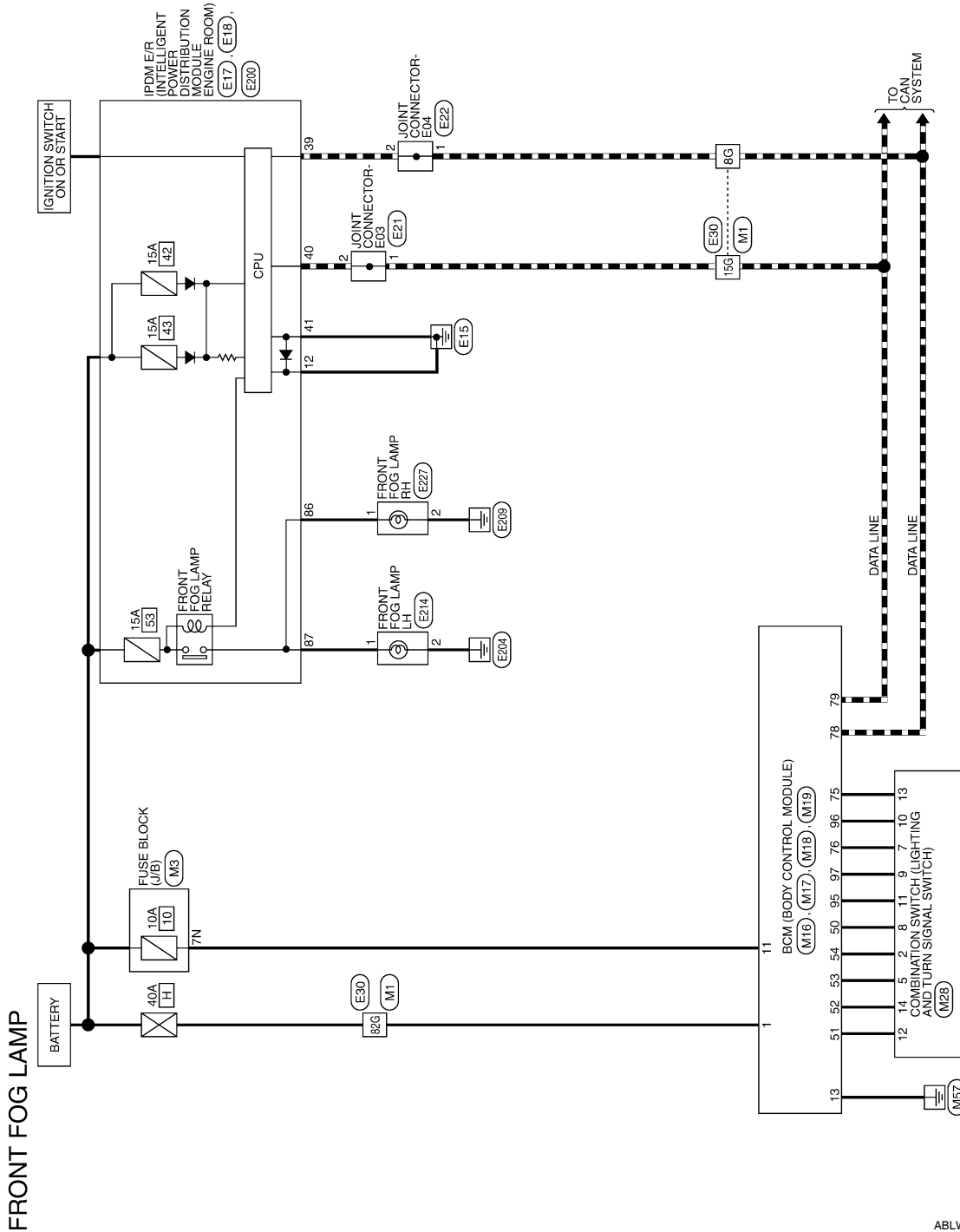

A
B
C
D
E
F
G
H
I
J
K
EXL
M
N
O
P

ABLWA0582GE

FRONT FOG LAMP SYSTEM

< COMPONENT DIAGNOSIS >

[XENON TYPE]

FRONT FOG LAMP CONNECTORS

Connector No.	M1
Connector Name	WIRE TO WIRE
Connector Color	WHITE

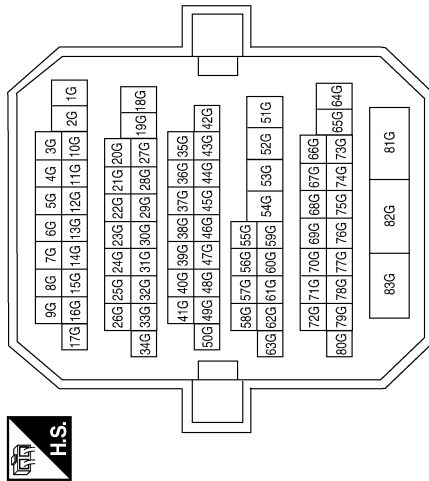

Terminal No.	Color of Wire	Signal Name
8G	P	-
15G	L	-
82G	W/B	-

Connector No.	M3
Connector Name	FUSE BLOCK (J/B)
Connector Color	WHITE

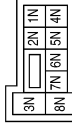

Terminal No.	Color of Wire	Signal Name
7N	Y/R	-

Connector No.	M16
Connector Name	BCM (BODY CONTROL MODULE)
Connector Color	BLACK



Terminal No.	Color of Wire	Signal Name
1	W/B	BATT (F/L)

Connector No.	M17
Connector Name	BCM (BODY CONTROL MODULE)
Connector Color	WHITE

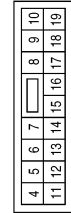

Terminal No.	Color of Wire	Signal Name
11	Y/R	BAT BCM FUSE
13	B	GND1

Connector No.	M18
Connector Name	BCM (BODY CONTROL MODULE)
Connector Color	GREEN

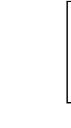

Terminal No.	Color of Wire	Signal Name
50	LG/B	OUTPUT 5
51	L/W	OUTPUT 1
52	G/B	OUTPUT 2
53	LG/R	OUTPUT 3
54	G/Y	OUTPUT 4

FRONT FOG LAMP SYSTEM

< COMPONENT DIAGNOSIS >

[XENON TYPE]

Connector No.	E17
Connector Name	IPDM E/R (INTELLIGENT POWER DISTRIBUTION MODULE ENGINE ROOM)
Connector Color	WHITE

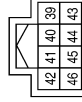

Terminal No.	Color of Wire	Signal Name
39	P	CAN-L
40	L	CAN-H
41	B	GND (SIGNAL)

Connector No.	M28
Connector Name	COMBINATION SWITCH
Connector Color	WHITE

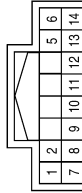

Terminal No.	Color of Wire	Signal Name
2	G/Y	OUTPUT 4
5	LG/R	OUTPUT 3
7	R/G	INPUT 3
8	LG/B	OUTPUT 5
9	R/B	INPUT 2
10	P/B	INPUT 4
11	R/W	INPUT 1
12	L/W	OUTPUT 1
13	R/Y	INPUT 5
14	G/B	OUTPUT 2

Connector No.	M19
Connector Name	BCM (BODY CONTROL MODULE)
Connector Color	BLACK

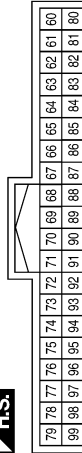

Terminal No.	Color of Wire	Signal Name
75	R/Y	INPUT 5
76	R/G	INPUT 3
78	P	CAN-L
79	L	CAN-H
95	R/W	INPUT 1
96	P/B	INPUT 4
97	R/B	INPUT 2

Connector No.	E21
Connector Name	JOINT CONNECTOR-E03
Connector Color	WHITE



Terminal No.	Color of Wire	Signal Name
1	L	-
2	L	-

Terminal No.	12
Color of Wire	B
Signal Name	GND (POWER)

Connector No.	E18
Connector Name	IPDM E/R (INTELLIGENT POWER DISTRIBUTION MODULE ENGINE ROOM)
Connector Color	WHITE

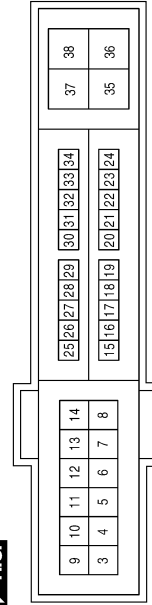

ABLIA1195GB

A
B
C
D
E
F
G
H
I
J
K
L
M
N
O
P

EXL

FRONT FOG LAMP SYSTEM

< COMPONENT DIAGNOSIS >

[XENON TYPE]

Terminal No.	Color of Wire	Signal Name
8G	P	-
15G	L	-
82G	LG	-

Connector No.	E30
Connector Name	WIRE TO WIRE
Connector Color	WHITE

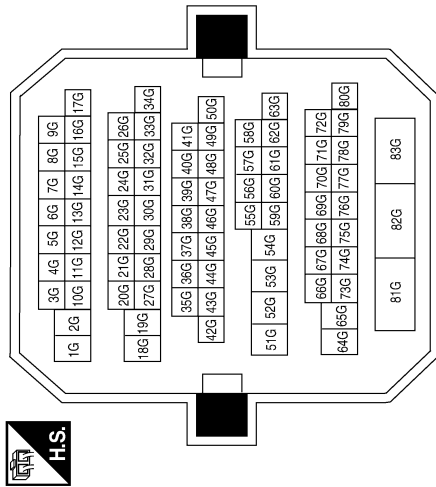

Connector No.	E227
Connector Name	FRONT FOG LAMP RH
Connector Color	BLACK

Connector No.	E214
Connector Name	FRONT FOG LAMP LH
Connector Color	BLACK



Terminal No.	Color of Wire	Signal Name
1	W/R	-
2	B	-

Terminal No.	Color of Wire	Signal Name
1	L/Y	-
2	B	-

Connector No.	E22
Connector Name	JOINT CONNECTOR-E04
Connector Color	WHITE



Terminal No.	Color of Wire	Signal Name
1	P	-
2	P	-

Connector No.	E200
Connector Name	IPDM E/R (INTELLIGENT POWER DISTRIBUTION MODULE ENGINE ROOM)
Connector Color	WHITE

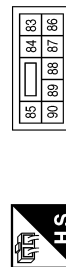

Terminal No.	Color of Wire	Signal Name
86	W/R	FR FOG LAMP RH
87	L/Y	FR FOG LAMP LH

ABLIA0513GB

TURN SIGNAL AND HAZARD WARNING LAMP SYSTEM

< COMPONENT DIAGNOSIS >

[XENON TYPE]

TURN SIGNAL AND HAZARD WARNING LAMP SYSTEM

Wiring Diagram

INFOID:000000005460875

TM: WITH TURN SIGNAL IN MIRROR

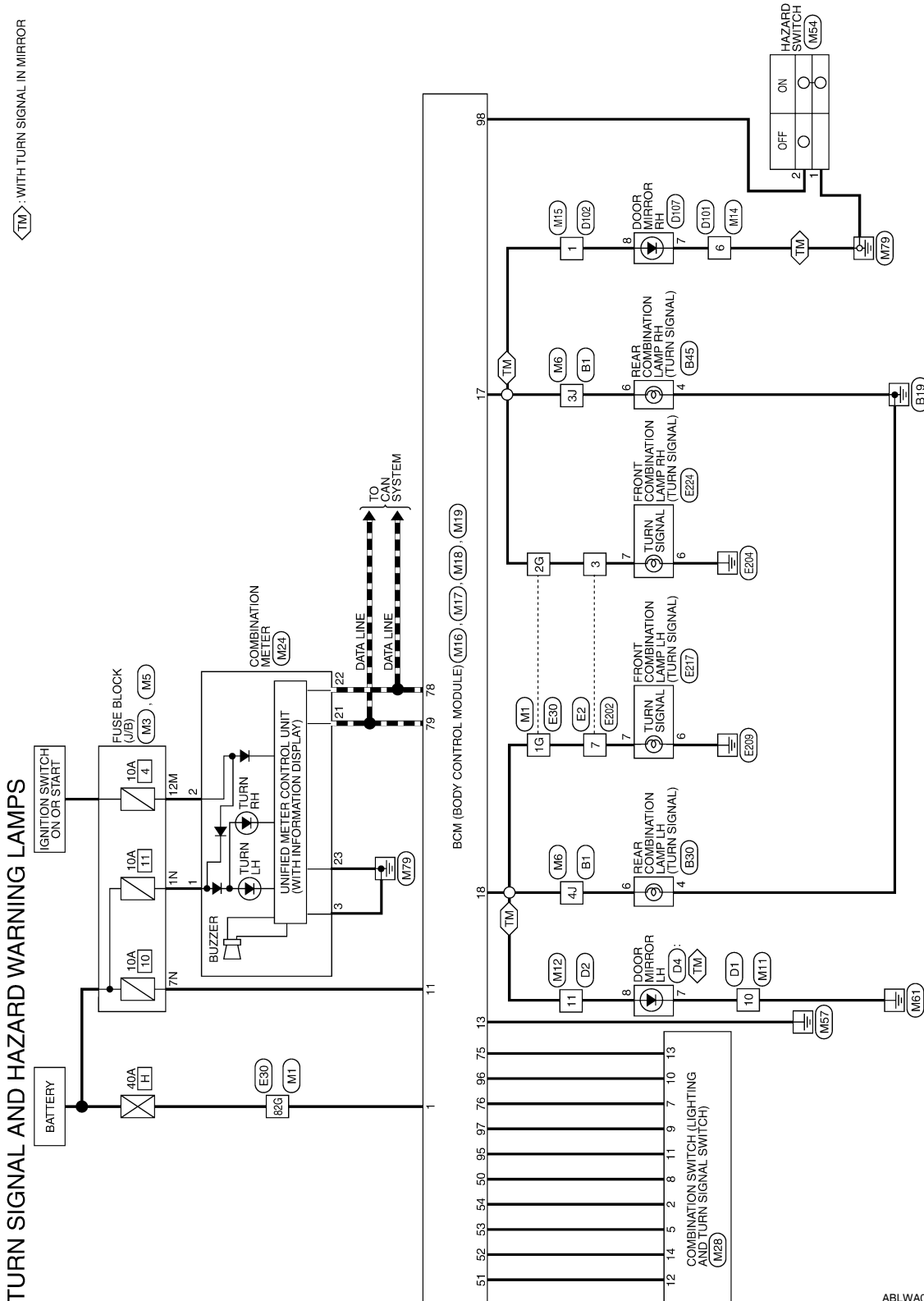

ABLWA0578GE

A
B
C
D
E
F
G
H
I
J
K
EXL
M
N
O
P

TURN SIGNAL AND HAZARD WARNING LAMP SYSTEM

< COMPONENT DIAGNOSIS >

[XENON TYPE]

TURN SIGNAL AND HAZARD WARNING LAMPS CONNECTORS

Connector No.	M1
Connector Name	WIRE TO WIRE
Connector Color	WHITE

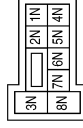
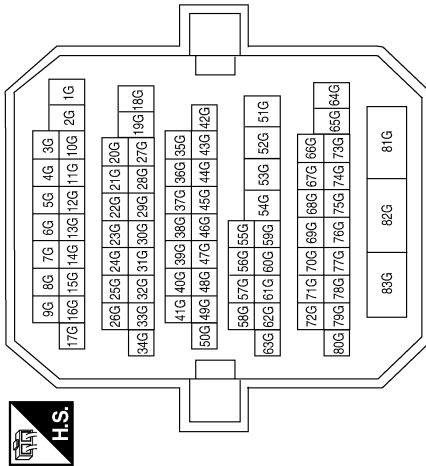

Terminal No.	Color of Wire	Signal Name
1G	G/Y	-
2G	G/B	-
82G	W/B	-

Connector No.	M3
Connector Name	FUSE BLOCK (J/B)
Connector Color	WHITE

Terminal No.	Color of Wire	Signal Name
1N	W/L	-
7N	Y/R	-

Connector No.	M5
Connector Name	FUSE BLOCK (J/B)
Connector Color	WHITE



Terminal No.	Color of Wire	Signal Name
12M	O	-

TURN SIGNAL AND HAZARD WARNING LAMP SYSTEM

< COMPONENT DIAGNOSIS >

[XENON TYPE]

Connector No.	M11
Connector Name	WIRE TO WIRE
Connector Color	WHITE

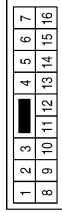

Terminal No.	10	Color of Wire	B	Signal Name	-
--------------	----	---------------	---	-------------	---

Terminal No.	3J 4J	Color of Wire	G/B G/Y	Signal Name	- -
--------------	----------	---------------	------------	-------------	--------

Connector No.	M6
Connector Name	WIRE TO WIRE
Connector Color	WHITE

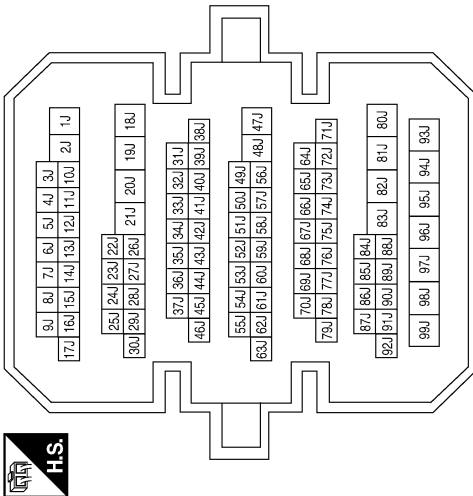

Connector No.	M15
Connector Name	WIRE TO WIRE
Connector Color	WHITE

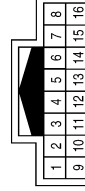

Terminal No.	1	Color of Wire	G/B	Signal Name	-
--------------	---	---------------	-----	-------------	---

Connector No.	M14
Connector Name	WIRE TO WIRE
Connector Color	WHITE

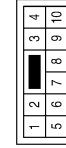

Terminal No.	6	Color of Wire	B	Signal Name	-
--------------	---	---------------	---	-------------	---

Connector No.	M12
Connector Name	WIRE TO WIRE
Connector Color	WHITE



Terminal No.	11	Color of Wire	G/Y	Signal Name	-
--------------	----	---------------	-----	-------------	---

A
B
C
D
E
F
G
H
I
J
K
L
M
N
O
P

EXL

TURN SIGNAL AND HAZARD WARNING LAMP SYSTEM

< COMPONENT DIAGNOSIS >

[XENON TYPE]

Connector No.	M18
Connector Name	BCM (BODY CONTROL MODULE)
Connector Color	GREEN



39	38	37	36	35	34	33	32	31	30	29	28	27	26	25	24	23	22	21	20
59	58	57	56	55	54	53	52	51	50	49	48	47	46	45	44	43	42	41	40

Terminal No.	Color of Wire	Signal Name
50	LG/B	OUTPUT 5
51	L/W	OUTPUT 1
52	G/B	OUTPUT 2
53	LG/R	OUTPUT 3
54	G/Y	OUTPUT 4

Connector No.	M17
Connector Name	BCM (BODY CONTROL MODULE)
Connector Color	WHITE



4	5	6	7	8	9	10		
11	12	13	14	15	16	17	18	19

Terminal No.	Color of Wire	Signal Name
11	Y/R	BAT BCM FUSE
13	B	GND1
17	G/B	FR FLASHER
18	G/Y	FL FLASHER

Connector No.	M16
Connector Name	BCM (BODY CONTROL MODULE)
Connector Color	BLACK



1	3
2	

Terminal No.	Color of Wire	Signal Name
1	W/B	BATT (F/L)

Connector No.	M24
Connector Name	COMBINATION METER
Connector Color	WHITE



1	2	3	4	5	6	7	8	9	10	11	12	13	14	15	16	17	18	19	20
21	22	23	24	25	26	27	28	29	30	31	32	33	34	35	36	37	38	39	40

Terminal No.	Color of Wire	Signal Name
1	W/L	BAT
2	O	IGN
3	B	GND (POWER)
21	L	CAN-H
22	P	CAN-L
23	B	GND (CIRCUIT)

Terminal No.	Color of Wire	Signal Name
75	R/Y	INPUT 5
76	R/G	INPUT 3
78	P	CAN-L
79	L	CAN-H
95	R/W	INPUT 1
96	P/B	INPUT 4
97	R/B	INPUT 2
98	G/O	HAZARD SW

Connector No.	M19
Connector Name	BCM (BODY CONTROL MODULE)
Connector Color	BLACK



79	78	77	76	75	74	73	72	71	70	69	68	67	66	65	64	63	62	61	60
99	98	97	96	95	94	93	92	91	90	89	88	87	86	85	84	83	82	81	80

ABLIA1719GB

TURN SIGNAL AND HAZARD WARNING LAMP SYSTEM

< COMPONENT DIAGNOSIS >

[XENON TYPE]

Connector No.	M28
Connector Name	COMBINATION SWITCH
Connector Color	WHITE

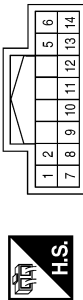

Terminal No.	Color of Wire	Signal Name
2	G/Y	OUTPUT 4
5	LG/R	OUTPUT 3
7	R/G	INPUT 3
8	LG/B	OUTPUT 5
9	R/B	INPUT 2
10	P/B	INPUT 4
11	R/W	INPUT 1
12	L/W	OUTPUT 1
13	R/Y	INPUT 5
14	G/B	OUTPUT 2

Connector No.	M54
Connector Name	HAZARD SWITCH
Connector Color	WHITE



Terminal No.	Color of Wire	Signal Name
1	B	-
2	G/O	-

Connector No.	E2
Connector Name	WIRE TO WIRE
Connector Color	WHITE



Terminal No.	Color of Wire	Signal Name
3	SB	-
7	Y	-

Connector No.	E30
Connector Name	WIRE TO WIRE
Connector Color	WHITE

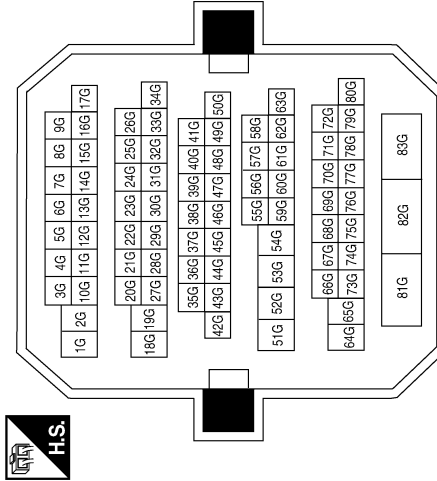

Terminal No.	Color of Wire	Signal Name
1G	Y	-
2G	SB	-
82G	LG	-

ABLIA1197GB

A
B
C
D
E
F
G
H
I
J
K
EXL
M
N
O
P

TURN SIGNAL AND HAZARD WARNING LAMP SYSTEM

< COMPONENT DIAGNOSIS >

[XENON TYPE]

Connector No.	E202
Connector Name	WIRE TO WIRE
Connector Color	WHITE

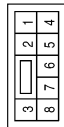

Terminal No.	Color of Wire	Signal Name
3	G/B	-
7	G/Y	-

Connector No.	E217
Connector Name	FRONT COMBINATION LAMP LH
Connector Color	GRAY



Terminal No.	Color of Wire	Signal Name
6	B	-
7	G/Y	-

Connector No.	E224
Connector Name	FRONT COMBINATION LAMP RH
Connector Color	GRAY



Terminal No.	Color of Wire	Signal Name
6	B	-
7	G/B	-

Connector No.	B1
Connector Name	WIRE TO WIRE
Connector Color	WHITE

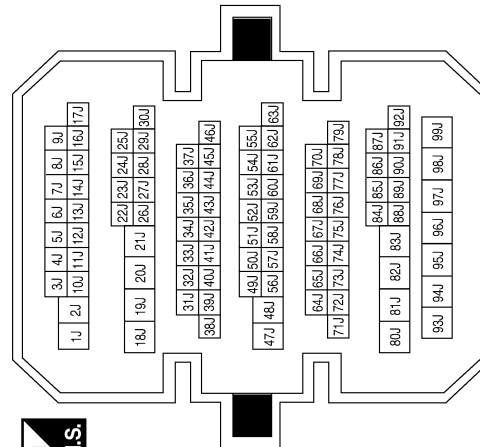

Connector No.	B30
Connector Name	REAR COMBINATION LAMP LH
Connector Color	WHITE



Terminal No.	Color of Wire	Signal Name
4	B	-
6	LG	-

TURN SIGNAL AND HAZARD WARNING LAMP SYSTEM

< COMPONENT DIAGNOSIS >

[XENON TYPE]

Connector No.	D2
Connector Name	WIRE TO WIRE
Connector Color	WHITE

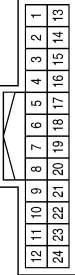
Terminal No.	Color of Wire	Signal Name
11	GR	-

Connector No.	D1
Connector Name	WIRE TO WIRE
Connector Color	WHITE

Terminal No.	Color of Wire	Signal Name
10	B	-

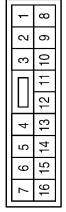
Connector No.	B45
Connector Name	REAR COMBINATION LAMP RH
Connector Color	WHITE

Terminal No.	Color of Wire	Signal Name
4	B	-
6	BR	-

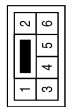
Connector No.	D102
Connector Name	WIRE TO WIRE
Connector Color	WHITE

Terminal No.	Color of Wire	Signal Name
1	W	-

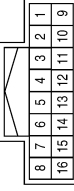
Connector No.	D101
Connector Name	WIRE TO WIRE
Connector Color	WHITE

Terminal No.	Color of Wire	Signal Name
6	B	-

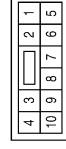
Connector No.	D4
Connector Name	DOOR MIRROR LH
Connector Color	WHITE

Terminal No.	Color of Wire	Signal Name
7	B	TURN(-)
8	GR	TURN(+)

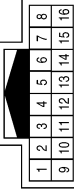
ABLIA0519GB

A
B
C
D
E
F
G
H
I
J
K
L
M
N
O
P

EXL

TURN SIGNAL AND HAZARD WARNING LAMP SYSTEM

< COMPONENT DIAGNOSIS >

[XENON TYPE]

Connector No.	D107
Connector Name	DOOR MIRROR RH
Connector Color	WHITE

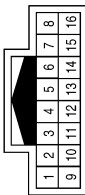

Terminal No.	Color of Wire	Signal Name
7	B	TURN(-)
8	W	TURN(+)

ABLIA0520GB

PARKING, LICENSE PLATE AND TAIL LAMPS SYSTEM

< COMPONENT DIAGNOSIS >

[XENON TYPE]

PARKING, LICENSE PLATE AND TAIL LAMPS SYSTEM

Wiring Diagram

INFOID:000000005460876

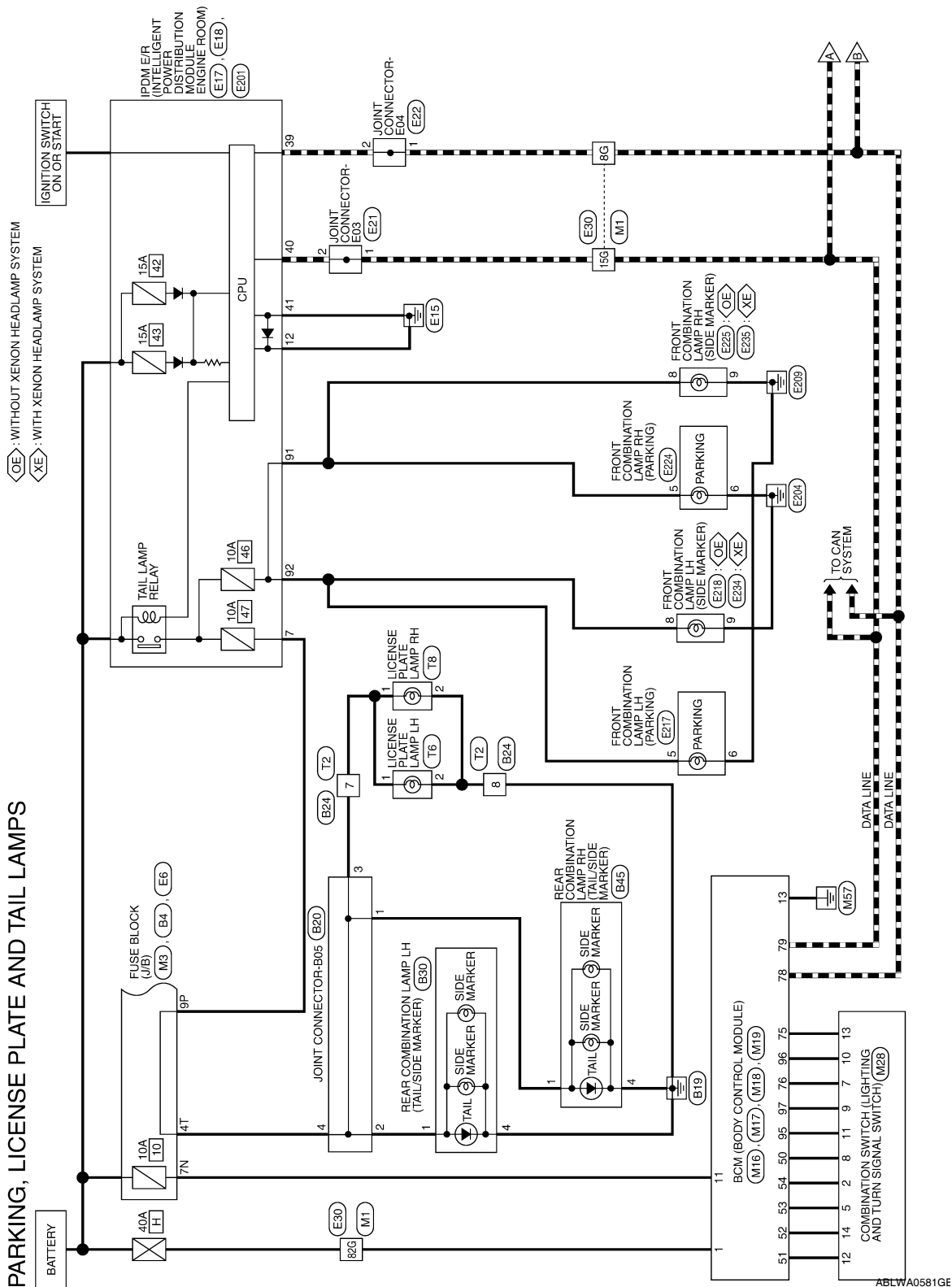

PARKING, LICENSE PLATE AND TAIL LAMPS SYSTEM

< COMPONENT DIAGNOSIS >

[XENON TYPE]

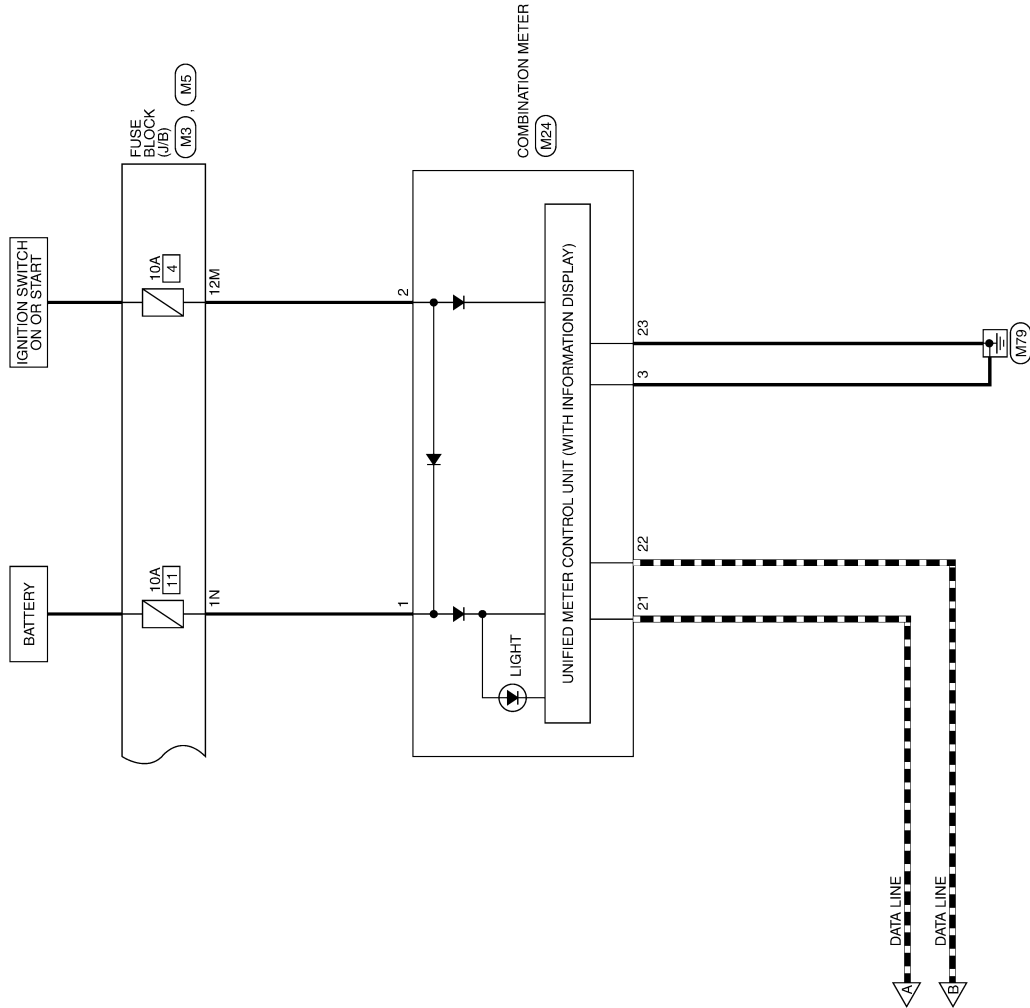

ABLWA0592GE

PARKING, LICENSE PLATE AND TAIL LAMPS SYSTEM

< COMPONENT DIAGNOSIS >

[XENON TYPE]

PARKING, LICENCE PLATE AND TAIL LAMPS CONNECTORS

Connector No.	M1
Connector Name	WIRE TO WIRE
Connector Color	WHITE

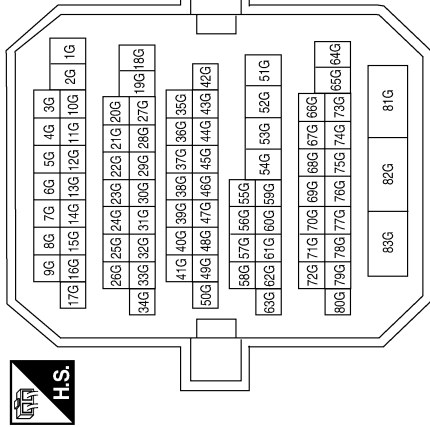

Terminal No.	Color of Wire	Signal Name
8G	P	-
15G	L	-
82G	W/B	-

Connector No.	M3
Connector Name	FUSE BLOCK (J/B)
Connector Color	WHITE

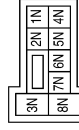

Terminal No.	Color of Wire	Signal Name
1N	W/L	-
7N	Y/R	-

Connector No.	M5
Connector Name	FUSE BLOCK (J/B)
Connector Color	WHITE

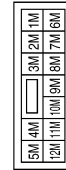

Terminal No.	12M	O	Signal Name	-
--------------	-----	---	-------------	---

Connector No.	M16
Connector Name	BCM (BODY CONTROL MODULE)
Connector Color	BLACK



Terminal No.	1	W/B	Signal Name	BATT (F/L)
--------------	---	-----	-------------	------------

Connector No.	M17
Connector Name	BCM (BODY CONTROL MODULE)
Connector Color	WHITE

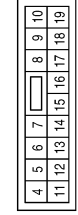

Terminal No.	11	Y/R	Signal Name	BAT BCM FUSE
	13	B	Signal Name	GND1

A
B
C
D
E
F
G
H
I
J
K
L
M
N
O
P

EXL

PARKING, LICENSE PLATE AND TAIL LAMPS SYSTEM

< COMPONENT DIAGNOSIS >

[XENON TYPE]

Connector No.	M24
Connector Name	COMBINATION METER
Connector Color	WHITE

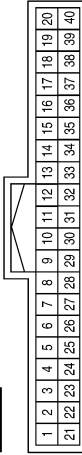

Terminal No.	Color of Wire	Signal Name
1	W/L	BAT
2	O	IGN
3	B	GND (POWER)
21	L	CAN-H
22	H	CAN-L
23	B	GND (CIRCUIT)

Connector No.	M19
Connector Name	BCM (BODY CONTROL MODULE)
Connector Color	BLACK



Terminal No.	Color of Wire	Signal Name
75	R/Y	INPUT 5
76	R/G	INPUT 3
78	P	CAN-L
79	L	CAN-H
95	R/W	INPUT 1
96	P/B	INPUT 4
97	R/B	INPUT 2

Connector No.	M18
Connector Name	BCM (BODY CONTROL MODULE)
Connector Color	GREEN

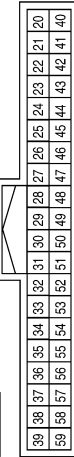

Terminal No.	Color of Wire	Signal Name
50	LG/B	OUTPUT 5
51	L/W	OUTPUT 1
52	G/B	OUTPUT 2
53	LG/R	OUTPUT 3
54	G/Y	OUTPUT 4

Connector No.	E6
Connector Name	FUSE BLOCK (J/B)
Connector Color	WHITE

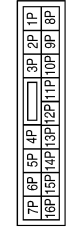

Terminal No.	Color of Wire	Signal Name
9P	GR	-

Terminal No.	Color of Wire	Signal Name
9	R/B	INPUT 2
10	P/B	INPUT 4
11	R/W	INPUT 1
12	L/W	OUTPUT 1
13	R/Y	INPUT 5
14	G/B	OUTPUT 2

Connector No.	M28
Connector Name	COMBINATION SWITCH
Connector Color	WHITE

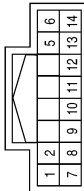

Terminal No.	Color of Wire	Signal Name
2	G/Y	OUTPUT 4
5	LG/R	OUTPUT 3
7	R/G	INPUT 3
8	LG/B	OUTPUT 5

ABLIA1756GB

PARKING, LICENSE PLATE AND TAIL LAMPS SYSTEM

< COMPONENT DIAGNOSIS >

[XENON TYPE]

Terminal No.	Color of Wire	Signal Name
7	GR	TAIL/ILLUMI
12	B	GND (POWER)

Connector No.	E18
Connector Name	IPDM E/R (INTELLIGENT POWER DISTRIBUTION MODULE ENGINE ROOM)
Connector Color	WHITE

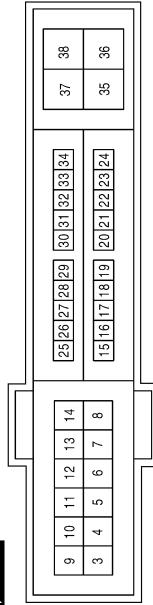

Connector No.	E17
Connector Name	IPDM E/R (INTELLIGENT POWER DISTRIBUTION MODULE ENGINE ROOM)
Connector Color	WHITE



Terminal No.	Color of Wire	Signal Name
39	P	CAN-L
40	L	CAN-H
41	B	GND (SIGNAL)

Connector No.	E22
Connector Name	JOINT CONNECTOR-E04
Connector Color	WHITE



Terminal No.	Color of Wire	Signal Name
1	P	-
2	P	-

Connector No.	E21
Connector Name	JOINT CONNECTOR-E03
Connector Color	WHITE



Terminal No.	Color of Wire	Signal Name
1	L	-
2	L	-

ABLIA1757GB

A
B
C
D
E
F
G
H
I
J
K
L
M
N
O
P

EXL

PARKING, LICENSE PLATE AND TAIL LAMPS SYSTEM

< COMPONENT DIAGNOSIS >

[XENON TYPE]

Connector No.	E201
Connector Name	IPDM E/R (INTELLIGENT POWER DISTRIBUTION MODULE ENGINE ROOM)
Connector Color	WHITE

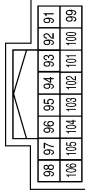

Terminal No.	Color of Wire	Signal Name
91	LG/R	CLEARANCE RH
92	LG/B	CLEARANCE LH

Terminal No.	Color of Wire	Signal Name
8G	P	-
15G	L	-
82G	LG	-

Connector No.	E30
Connector Name	WIRE TO WIRE
Connector Color	WHITE

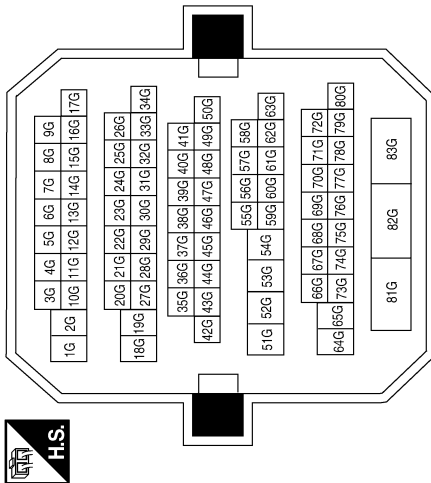

Connector No.	E224
Connector Name	FRONT COMBINATION LAMP RH
Connector Color	GRAY



Terminal No.	Color of Wire	Signal Name
5	LG/R	-
6	B	-

Connector No.	E218
Connector Name	FRONT COMBINATION LAMP LH (WITHOUT XENON HEADLAMP SYSTEM)
Connector Color	GRAY



Terminal No.	Color of Wire	Signal Name
8	LG/B	-
9	B	-

Connector No.	E217
Connector Name	FRONT COMBINATION LAMP LH
Connector Color	GRAY



Terminal No.	Color of Wire	Signal Name
5	LG/B	-
6	B	-

ABLIA1720GB

PARKING, LICENSE PLATE AND TAIL LAMPS SYSTEM

< COMPONENT DIAGNOSIS >

[XENON TYPE]

Connector No.	E235
Connector Name	FRONT COMBINATION LAMP RH (WITH XENON HEADLAMP SYSTEM)
Connector Color	GRAY



Terminal No.	Color of Wire	Signal Name
8	LG/R	-
9	B	-

Connector No.	E234
Connector Name	FRONT COMBINATION LAMP LH (WITH XENON HEADLAMP SYSTEM)
Connector Color	GRAY



Terminal No.	Color of Wire	Signal Name
8	LG/B	-
9	B	-

Connector No.	E225
Connector Name	FRONT COMBINATION LAMP RH (WITHOUT XENON HEADLAMP SYSTEM)
Connector Color	GRAY



Terminal No.	Color of Wire	Signal Name
8	LG/R	-
9	B	-

Connector No.	B24
Connector Name	WIRE TO WIRE
Connector Color	WHITE

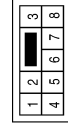

Terminal No.	Color of Wire	Signal Name
7	L	-
8	B	-

Connector No.	B20
Connector Name	JOINT CONNECTOR-B05
Connector Color	BLUE



Terminal No.	Color of Wire	Signal Name
1	L	-
2	L	-
3	L	-
4	L	-

Connector No.	B4
Connector Name	FUSE BLOCK (J/B)
Connector Color	BROWN

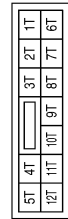

Terminal No.	Color of Wire	Signal Name
4T	L	-

ABLIA1721GB

A
B
C
D
E
F
G
H
I
J
K
L
M
N
O
P

EXL

PARKING, LICENSE PLATE AND TAIL LAMPS SYSTEM

< COMPONENT DIAGNOSIS >

[XENON TYPE]

Connector No.	T2
Connector Name	WIRE TO WIRE
Connector Color	WHITE

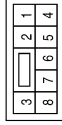

Terminal No.	Color of Wire	Signal Name
7	L	-
8	B	-

Connector No.	B45
Connector Name	REAR COMBINATION LAMP RH
Connector Color	WHITE

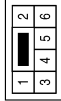

Terminal No.	Color of Wire	Signal Name
1	L	-
4	B	-

Connector No.	B30
Connector Name	REAR COMBINATION LAMP LH
Connector Color	WHITE

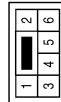

Terminal No.	Color of Wire	Signal Name
1	L	-
4	B	-

Connector No.	T8
Connector Name	LICENSE PLATE LAMP RH
Connector Color	BROWN



Terminal No.	Color of Wire	Signal Name
1	L	-
2	B	-

Connector No.	T6
Connector Name	LICENSE PLATE LAMP LH
Connector Color	BROWN



Terminal No.	Color of Wire	Signal Name
1	L	-
2	B	-

ABLIA1722GB

STOP LAMP

< COMPONENT DIAGNOSIS >

[XENON TYPE]

STOP LAMP

Wiring Diagram

INFOID:000000005460877

- ◇ OS : WITHOUT REAR SPOILER
- ◇ RS : WITH REAR SUNSHADE
- ◇ RT : WITHOUT REAR SUNSHADE
- ◇ SP : WITH REAR SPOILER

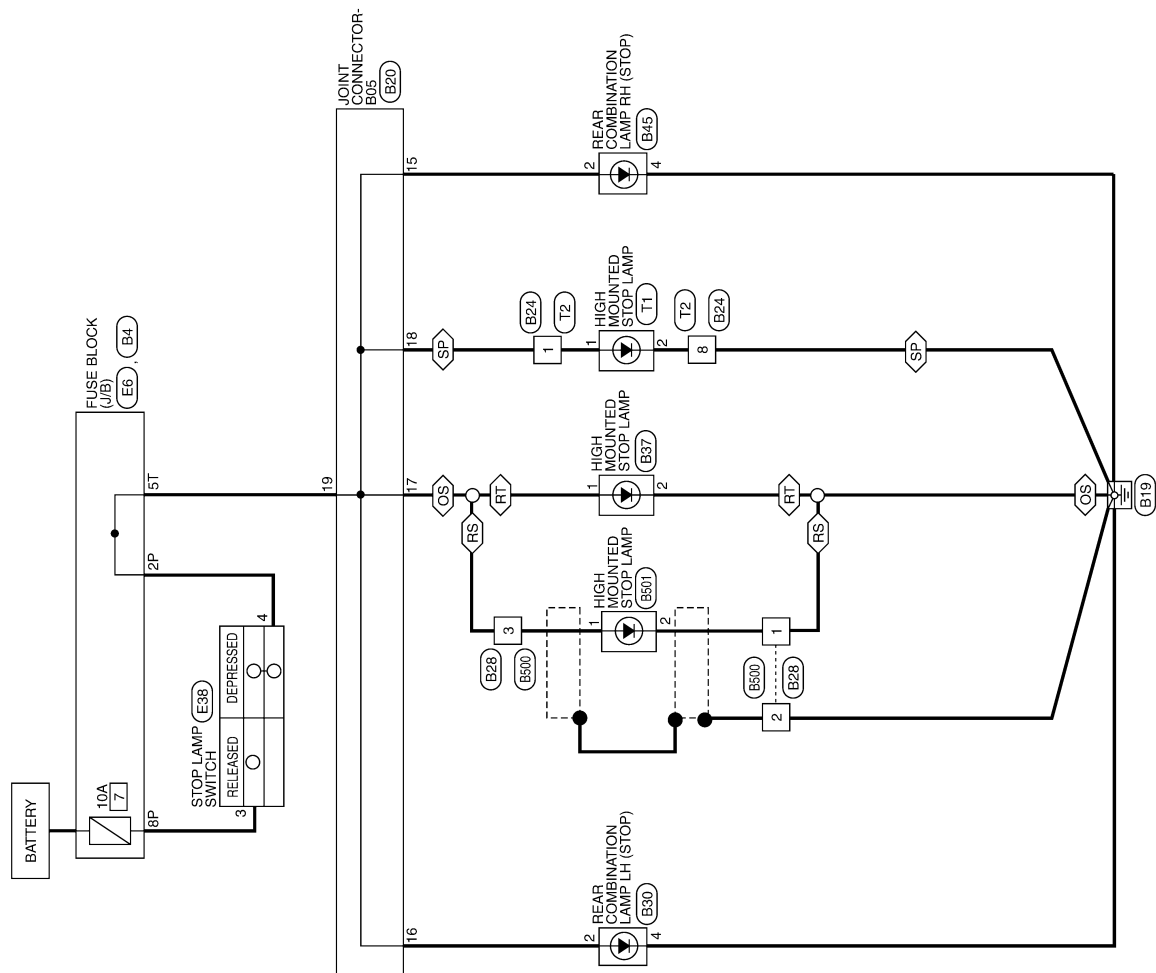

STOP LAMP

ABLWA0583GE

A
B
C
D
E
F
G
H
I
J
K
EXL
M
N
O
P

STOP LAMP

< COMPONENT DIAGNOSIS >

[XENON TYPE]

STOP LAMP CONNECTORS

Connector No.	E6
Connector Name	FUSE BLOCK (J/B)
Connector Color	WHITE



Terminal No.	Color of Wire	Signal Name
2P	LG	-
8P	R	-

Connector No.	E38
Connector Name	STOP LAMP SWITCH
Connector Color	WHITE



Terminal No.	Color of Wire	Signal Name
3	R	-
4	LG	-

Connector No.	B4
Connector Name	FUSE BLOCK (J/B)
Connector Color	BROWN

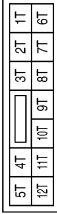

Terminal No.	Color of Wire	Signal Name
5T	O	-

Connector No.	B20
Connector Name	JOINT CONNECTOR-B05
Connector Color	BLUE

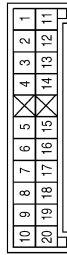

Terminal No.	Color of Wire	Signal Name
15	O	-
16	O	-
17	O	-
18	O	-
19	O	-

Connector No.	B24
Connector Name	WIRE TO WIRE
Connector Color	WHITE

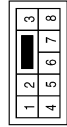

Terminal No.	Color of Wire	Signal Name
1	O	-
8	B	-

Connector No.	B28
Connector Name	WIRE TO WIRE
Connector Color	WHITE



Terminal No.	Color of Wire	Signal Name
1	B	-
2	B	-
3	O	-

STOP LAMP

< COMPONENT DIAGNOSIS >

[XENON TYPE]

Connector No.	B45
Connector Name	REAR COMBINATION LAMP RH
Connector Color	WHITE

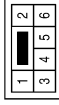

Terminal No.	Color of Wire	Signal Name
2	O	-
4	B	-

Connector No.	B37
Connector Name	HIGH MOUNTED STOP LAMP (WITHOUT REAR SPOILER AND REAR SUNSHADE)
Connector Color	WHITE



Terminal No.	Color of Wire	Signal Name
1	O	-
2	B	-

Connector No.	B30
Connector Name	REAR COMBINATION LAMP LH
Connector Color	WHITE

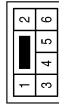

Terminal No.	Color of Wire	Signal Name
2	O	-
4	B	-

Connector No.	T1
Connector Name	HIGH MOUNTED STOP LAMP (WITH REAR SPOILER)
Connector Color	BROWN



Terminal No.	Color of Wire	Signal Name
1	O	-
2	B	-

Connector No.	B501
Connector Name	HIGH MOUNTED STOP LAMP (WITHOUT REAR SPOILER AND WITH REAR SUNSHADE)
Connector Color	GRAY



Terminal No.	Color of Wire	Signal Name
1	O	+
2	B	-

Connector No.	B500
Connector Name	WIRE TO WIRE
Connector Color	WHITE



Terminal No.	Color of Wire	Signal Name
1	B	-
2	B	-
3	O	-

ABLIA1754GB

A
B
C
D
E
F
G
H
I
J
K
EXL
M
N
O
P

STOP LAMP

< COMPONENT DIAGNOSIS >

[XENON TYPE]

Connector No.	T2
Connector Name	WIRE TO WIRE
Connector Color	WHITE

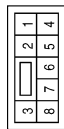

Terminal No.	Color of Wire	Signal Name
1	O	-
8	B	-

ABLIA0528GB

BACK-UP LAMP

< COMPONENT DIAGNOSIS >

[XENON TYPE]

BACK-UP LAMP

Wiring Diagram

INFOID:000000005460878

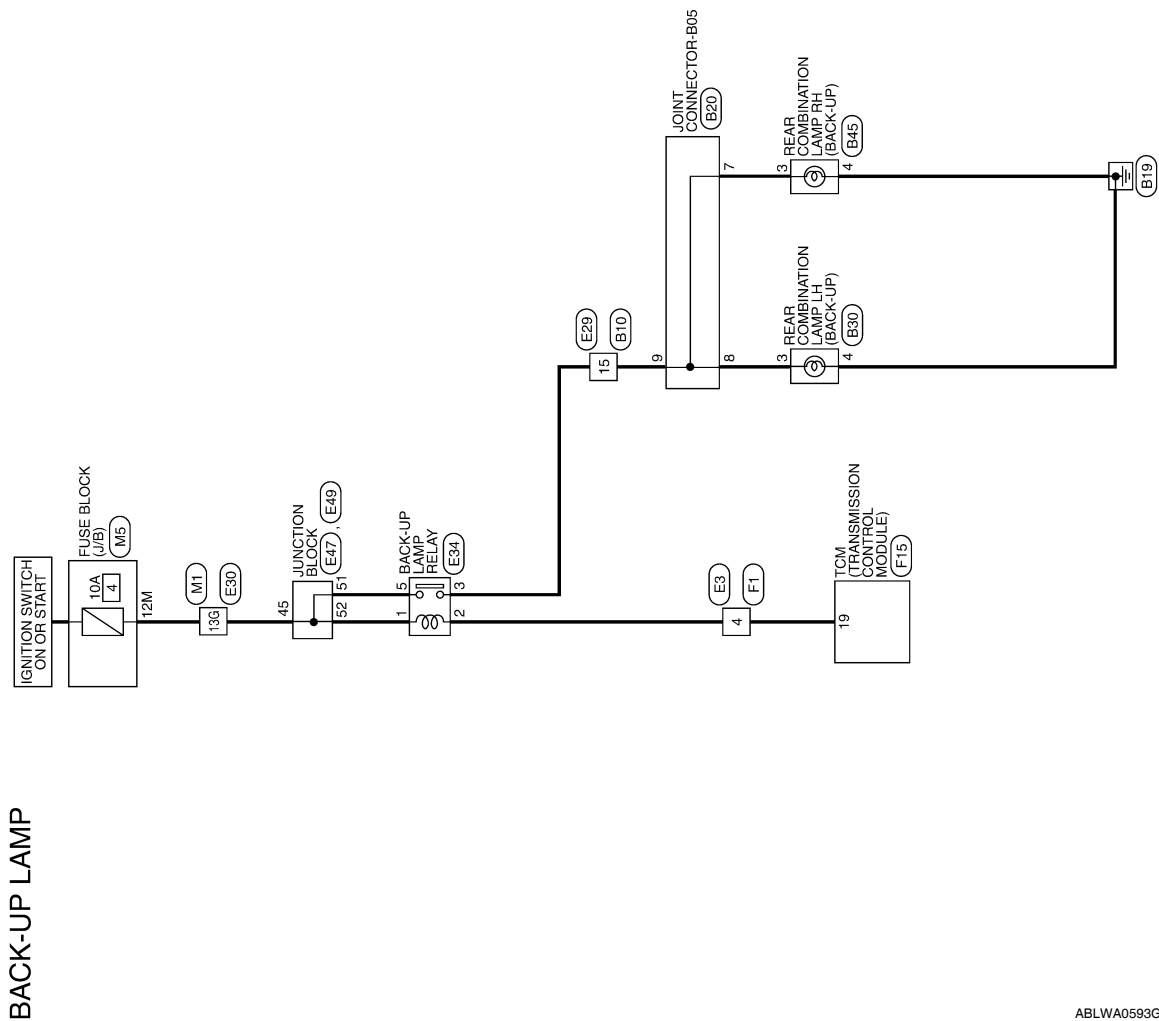

A
B
C
D
E
F
G
H
I
J
K
EXL
M
N
O
P

BACK-UP LAMP

< COMPONENT DIAGNOSIS >

[XENON TYPE]

BACK-UP LAMP CONNECTORS

Connector No.	M1
Connector Name	WIRE TO WIRE
Connector Color	WHITE

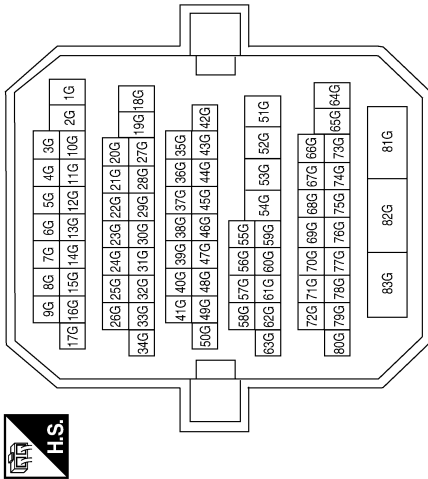

Terminal No.	Color of Wire	Signal Name
13G	O	-

Connector No.	M5
Connector Name	FUSE BLOCK (J/B)
Connector Color	WHITE

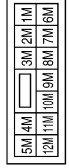

Terminal No.	Color of Wire	Signal Name
12M	O	-

Connector No.	E3
Connector Name	WIRE TO WIRE
Connector Color	WHITE

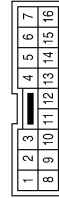

Terminal No.	Color of Wire	Signal Name
4	R	-

Connector No.	E29
Connector Name	WIRE TO WIRE
Connector Color	WHITE

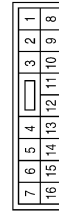

Terminal No.	Color of Wire	Signal Name
15	W	-

BACK-UP LAMP

< COMPONENT DIAGNOSIS >

[XENON TYPE]

Connector No.	E34
Connector Name	BACK-UP LAMP RELAY
Connector Color	BLUE



Terminal No.	Color of Wire	Signal Name
1	O	-
2	R	-
3	W	-
5	LG	-

Terminal No.	Color of Wire	Signal Name
13G	BR	-

Connector No.	E30
Connector Name	WIRE TO WIRE
Connector Color	WHITE

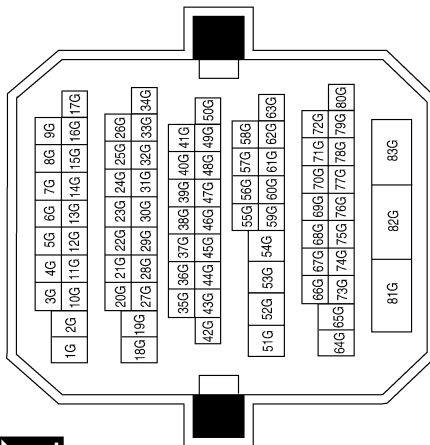

Connector No.	E49
Connector Name	JUNCTION BLOCK
Connector Color	BROWN

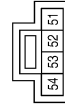

Terminal No.	Color of Wire	Signal Name
51	LG	-
52	O	-

Connector No.	E47
Connector Name	JUNCTION BLOCK
Connector Color	WHITE



Terminal No.	Color of Wire	Signal Name
45	BR	-

A
B
C
D
E
F
G
H
I
J
K
L
M
N
O
P

EXL

BACK-UP LAMP

< COMPONENT DIAGNOSIS >

[XENON TYPE]

Connector No.	B10
Connector Name	WIRE TO WIRE
Connector Color	WHITE

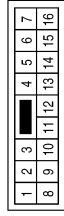

Terminal No.	15	Color of Wire	V	Signal Name	-
--------------	----	---------------	---	-------------	---

Connector No.	F15
Connector Name	TCM (TRANSMISSION CONTROL MODULE)
Connector Color	BLACK

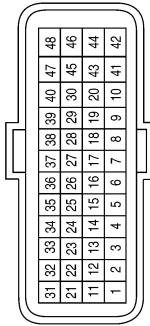

Terminal No.	19	Color of Wire	G/B	Signal Name	REV LAMP RLY
--------------	----	---------------	-----	-------------	--------------

Connector No.	F1
Connector Name	WIRE TO WIRE
Connector Color	WHITE

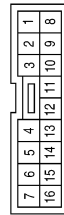

Terminal No.	4	Color of Wire	G/B	Signal Name	-
--------------	---	---------------	-----	-------------	---

Connector No.	B45
Connector Name	REAR COMBINATION LAMP RH
Connector Color	WHITE

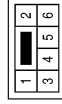

Terminal No.	3	Color of Wire	V	Signal Name	-
4	B	-	-		

Connector No.	B30
Connector Name	REAR COMBINATION LAMP LH
Connector Color	WHITE

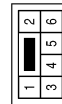

Terminal No.	3	Color of Wire	V	Signal Name	-
4	B	-	-		

Connector No.	B20
Connector Name	JOINT CONNECTOR-B05
Connector Color	BLUE

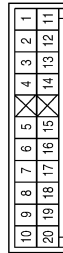

Terminal No.	7	Color of Wire	V	Signal Name	-
8	V	-	-		
9	V	-	-		

ABLIA1723GB

BCM (BODY CONTROL MODULE)

< ECU DIAGNOSIS >

[XENON TYPE]

ECU DIAGNOSIS

BCM (BODY CONTROL MODULE)

Reference Value

INFOID:000000005530146

VALUES ON THE DIAGNOSIS TOOL

Monitor Item	Condition	Value/Status
FR WIPER HI	Other than front wiper switch HI	OFF
	Front wiper switch HI	ON
FR WIPER LOW	Other than front wiper switch LO	OFF
	Front wiper switch LO	ON
FR WASHER SW	Front washer switch OFF	OFF
	Front washer switch ON	ON
FR WIPER INT	Other than front wiper switch INT	OFF
	Front wiper switch INT	ON
FR WIPER STOP	Front wiper is not in STOP position	OFF
	Front wiper is in STOP position	ON
INT VOLUME	Wiper intermittent dial is in a dial position 1 - 7	Wiper intermittent dial position
TURN SIGNAL R	Other than turn signal switch RH	OFF
	Turn signal switch RH	ON
TURN SIGNAL L	Other than turn signal switch LH	OFF
	Turn signal switch LH	ON
TAIL LAMP SW	Other than lighting switch 1ST and 2ND	OFF
	Lighting switch 1ST or 2ND	ON
HI BEAM SW	Other than lighting switch HI	OFF
	Lighting switch HI	ON
HEAD LAMP SW 1	Other than lighting switch 2ND	OFF
	Lighting switch 2ND	ON
HEAD LAMP SW 2	Other than lighting switch 2ND	OFF
	Lighting switch 2ND	ON
PASSING SW	Other than lighting switch PASS	OFF
	Lighting switch PASS	ON
AUTO LIGHT SW	Other than lighting switch AUTO	OFF
	Lighting switch AUTO	ON
FR FOG SW	Front fog lamp switch OFF	OFF
	Front fog lamp switch ON	ON
DOOR SW-DR	Driver door closed	OFF
	Driver door opened	ON
DOOR SW-AS	Passenger door closed	OFF
	Passenger door opened	ON
DOOR SW-RR	Rear door RH closed	OFF
	Rear door RH opened	ON
DOOR SW-RL	Rear door LH closed	OFF
	Rear door LH opened	ON

BCM (BODY CONTROL MODULE)

< ECU DIAGNOSIS >

[XENON TYPE]

Monitor Item	Condition	Value/Status
CDL LOCK SW	Other than power door lock switch LOCK	OFF
	Power door lock switch LOCK	ON
CDL UNLOCK SW	Other than power door lock switch UNLOCK	OFF
	Power door lock switch UNLOCK	ON
KEY CYL LK-SW	Other than driver door key cylinder LOCK position	OFF
	Driver door key cylinder LOCK position	ON
KEY CYL UN-SW	Other than driver door key cylinder UNLOCK position	OFF
	Driver door key cylinder UNLOCK position	ON
HAZARD SW	When hazard switch is not pressed	OFF
	When hazard switch is pressed	ON
REAR DEF SW	When rear window defogger switch is pressed	ON
TR CANCEL SW	Trunk lid opener cancel switch OFF	OFF
	Trunk lid opener cancel switch ON	ON
TR/BD OPEN SW	Trunk lid opener switch OFF	OFF
	While the trunk lid opener switch is turned ON	ON
TRNK/HAT MNTR	Trunk lid closed	OFF
	Trunk lid opened	ON
RKE-LOCK	When LOCK button of Intelligent Key is not pressed	OFF
	When LOCK button of Intelligent Key is pressed	ON
RKE-UNLOCK	When UNLOCK button of Intelligent Key is not pressed	OFF
	When UNLOCK button of Intelligent Key is pressed	ON
RKE-TR/BD	When TRUNK OPEN button of Intelligent Key is not pressed	OFF
	When TRUNK OPEN button of Intelligent Key is pressed	ON
RKE-PANIC	When PANIC button of Intelligent Key is not pressed	OFF
	When PANIC button of Intelligent Key is pressed	ON
RKE-P/W OPEN	When UNLOCK button of Intelligent Key is not pressed and held	OFF
	When UNLOCK button of Intelligent Key is pressed and held	ON
RKE-MODE CHG	When LOCK/UNLOCK button of Intelligent Key is not pressed and held simultaneously	OFF
	When LOCK/UNLOCK button of Intelligent Key is pressed and held simultaneously	ON
OPTICAL SENSOR	When outside of the vehicle is bright	Close to 5 V
	When outside of the vehicle is dark	Close to 0 V
REQ SW-DR	When front door request switch is not pressed (driver side)	OFF
	When front door request switch is pressed (driver side)	ON
REQ SW-AS	When front door request switch is not pressed (passenger side)	OFF
	When front door request switch is pressed (passenger side)	ON
REQ SW-RL	When rear door request switch is not pressed (driver side)	OFF
	When rear door request switch is pressed (driver side)	ON
REQ SW-RR	When rear door request switch is not pressed (passenger side)	OFF
	When rear door request switch is pressed (passenger side)	ON
REQ SW-BD/TR	When trunk request switch is not pressed	OFF
	When trunk request switch is pressed	ON
PUSH SW	When engine switch (push switch) is not pressed	OFF
	When engine switch (push switch) is pressed	ON

BCM (BODY CONTROL MODULE)

< ECU DIAGNOSIS >

[XENON TYPE]

Monitor Item	Condition	Value/Status	
IGN RLY 2-F/B	Ignition switch OFF or ACC	OFF	A
	Ignition switch ON	ON	
ACC RLY-F/B	Ignition switch OFF	OFF	B
	Ignition switch ACC or ON	ON	
BRAKE SW 1	When the brake pedal is not depressed	ON	C
	When the brake pedal is depressed	OFF	
DETE/CANCL SW	When selector lever is in P position	OFF	D
	When selector lever is in any position other than P	ON	
SFT PN/N SW	When selector lever is in any position other than P or N	OFF	E
	When selector lever is in P or N position	ON	
S/L-LOCK*	Electronic steering column lock LOCK status	OFF	F
	Electronic steering column lock UNLOCK status	ON	
S/L-UNLOCK*	Electronic steering column lock UNLOCK status	OFF	G
	Electronic steering column lock LOCK status	ON	
S/L RELAY-F/B*	Ignition switch OFF or ACC	OFF	H
	Ignition switch ON	ON	
UNLK SEN-DR	Driver door UNLOCK status	OFF	I
	Driver door LOCK status	ON	
PUSH SW-IPDM	When engine switch (push switch) is not pressed	OFF	J
	When engine switch (push switch) is pressed	ON	
IGN RLY1 F/B	Ignition switch OFF or ACC	OFF	K
	Ignition switch ON	ON	
DETE SW -IPDM	When selector lever is in P position	OFF	EXL
	When selector lever is in any position other than P	ON	
SFT PN -IPDM	When selector lever is in any position other than P or N	OFF	M
	When selector lever is in P or N position	ON	
SFT P-MET	When selector lever is in any position other than P	OFF	N
	When selector lever is in P position	ON	
SFT N-MET	When selector lever is in any position other than N	OFF	O
	When selector lever is in N position	ON	
ENGINE STATE	Engine stopped	STOP	P
	While the engine stalls	STALL	
	At engine cranking	CRANK	
	Engine running	RUN	
S/L LOCK-IPDM*	Electronic steering column lock LOCK status	OFF	
	Electronic steering column lock UNLOCK status	ON	
S/L UNLK-IPDM*	Electronic steering column lock UNLOCK status	OFF	
	Electronic steering column lock LOCK status	ON	
S/L RELAY-REQ*	Ignition switch OFF or ACC	OFF	
	Ignition switch ON	ON	
VEH SPEED 1	While driving	Equivalent to speedometer reading	
VEH SPEED 2	While driving	Equivalent to speedometer reading	

BCM (BODY CONTROL MODULE)

< ECU DIAGNOSIS >

[XENON TYPE]

Monitor Item	Condition	Value/Status
DOOR STAT-DR	Driver door LOCK status	LOCK
	Wait with selective UNLOCK operation (5 seconds)	READY
	Driver door UNLOCK status	UNLK
DOOR STAT-AS	Passenger door LOCK status	LOCK
	Wait with selective UNLOCK operation (5 seconds)	READY
	Passenger door UNLOCK status	UNLK
ID OK FLAG	Ignition switch ACC or ON	RESET
	Ignition switch OFF	SET
PRMT ENG STRT	When the engine start is prohibited	RESET
	When the engine start is permitted	SET
KEY SW -SLOT	When Intelligent Key is not inserted into key slot	OFF
	When Intelligent Key is inserted into key slot	ON
RKE OPE COUN1	During the operation of Intelligent Key	Operation frequency of Intelligent Key
CONFIRM ID ALL	The key ID that the key slot receives does not accord with any key ID registered to BCM.	YET
	The key ID that the key slot receives accords with any key ID registered to BCM.	DONE
CONFIRM ID4	The key ID that the key slot receives does not accord with the fourth key ID registered to BCM.	YET
	The key ID that the key slot receives accords with the fourth key ID registered to BCM.	DONE
CONFIRM ID3	The key ID that the key slot receives does not accord with the third key ID registered to BCM.	YET
	The key ID that the key slot receives accords with the third key ID registered to BCM.	DONE
CONFIRM ID2	The key ID that the key slot receives does not accord with the second key ID registered to BCM.	YET
	The key ID that the key slot receives accords with the second key ID registered to BCM.	DONE
CONFIRM ID1	The key ID that the key slot receives does not accord with the first key ID registered to BCM.	YET
	The key ID that the key slot receives accords with the first key ID registered to BCM.	DONE
TP 4	The ID of fourth key is not registered to BCM	YET
	The ID of fourth key is registered to BCM	DONE
TP 3	The ID of third key is not registered to BCM	YET
	The ID of third key is registered to BCM	DONE
TP 2	The ID of second key is not registered to BCM	YET
	The ID of second key is registered to BCM	DONE
TP 1	The ID of first key is not registered to BCM	YET
	The ID of first key is registered to BCM	DONE
AIR PRESS FL	Ignition switch ON (only when the signal from the transmitter is received)	Air pressure of front LH tire
AIR PRESS FR	Ignition switch ON (only when the signal from the transmitter is received)	Air pressure of front RH tire
AIR PRESS RR	Ignition switch ON (only when the signal from the transmitter is received)	Air pressure of rear RH tire
AIR PRESS RL	Ignition switch ON (only when the signal from the transmitter is received)	Air pressure of rear LH tire

BCM (BODY CONTROL MODULE)

< ECU DIAGNOSIS >

[XENON TYPE]

Monitor Item	Condition	Value/Status
ID REGST FL1	When ID of front LH tire transmitter is registered	DONE
	When ID of front LH tire transmitter is not registered	YET
ID REGST FR1	When ID of front RH tire transmitter is registered	DONE
	When ID of front RH tire transmitter is not registered	YET
ID REGST RR1	When ID of rear RH tire transmitter is registered	DONE
	When ID of rear RH tire transmitter is not registered	YET
ID REGST RL1	When ID of rear LH tire transmitter is registered	DONE
	When ID of rear LH tire transmitter is not registered	YET
WARNING LAMP	Tire pressure indicator OFF	OFF
	Tire pressure indicator ON	ON
BUZZER	Tire pressure warning alarm is not sounding	OFF
	Tire pressure warning alarm is sounding	ON

* : With electronic steering column lock

A
B
C
D
E
F
G
H
I
J
K
L
M
N
O
P

EXL

BCM (BODY CONTROL MODULE)

< ECU DIAGNOSIS >

[XENON TYPE]

Terminal Layout

INFOID:000000005530147

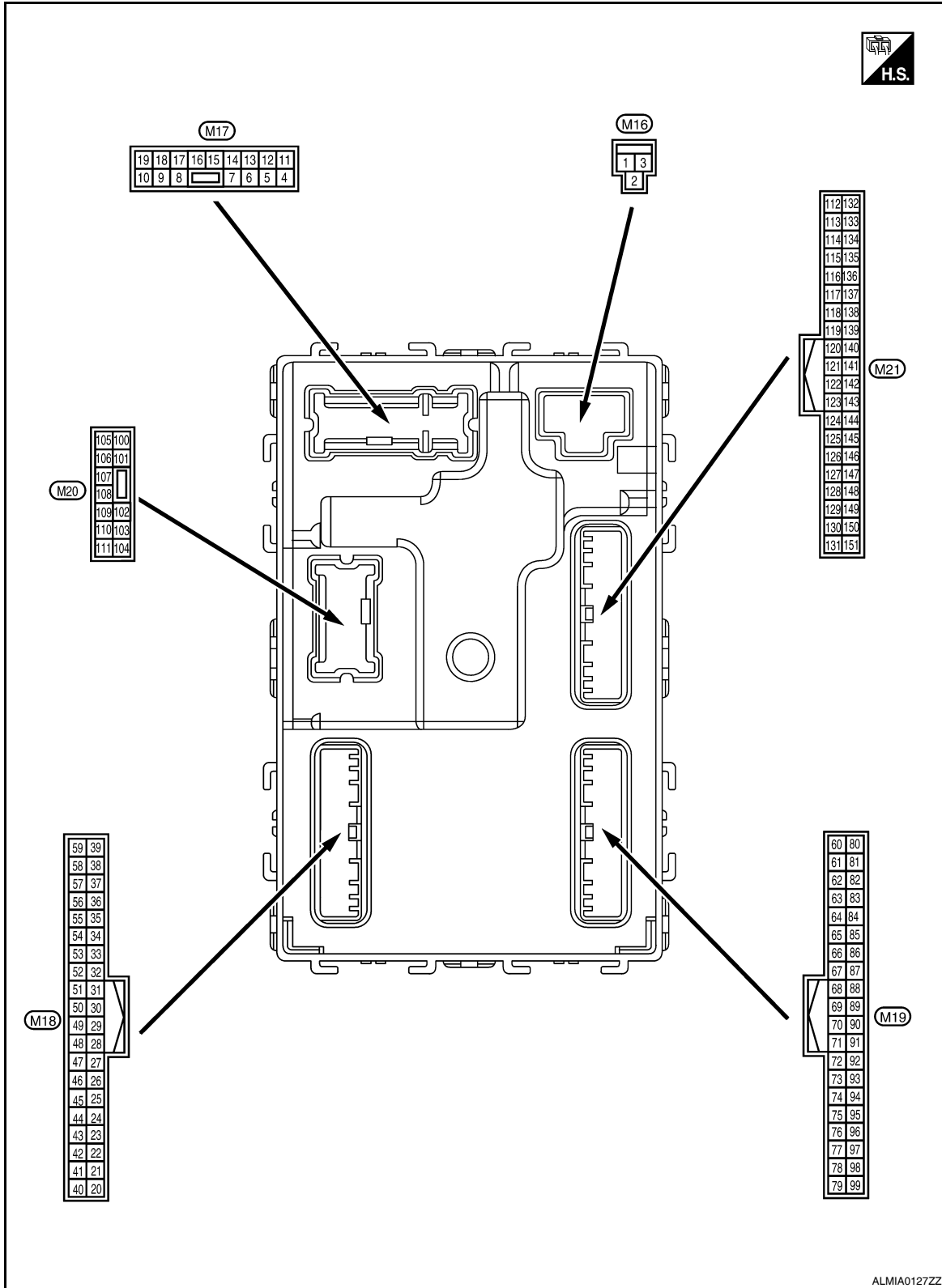

Physical Values

INFOID:000000005530148

BCM (BODY CONTROL MODULE)

< ECU DIAGNOSIS >

[XENON TYPE]

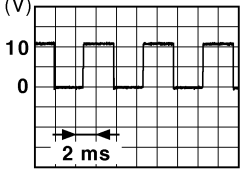
Terminal No. (Wire color)		Description		Condition		Value (Approx.)
		Signal name	Input/ Output			
(+)	(-)					
1 (W/B)	Ground	Battery power supply	Input	Ignition switch OFF		Battery voltage
2 (R/Y)	Ground	Battery power supply output	Output	Ignition switch OFF		Battery voltage
3 (L/W)	Ground	Ignition power supply output	Output	Ignition switch ON		Battery voltage
4 (P/W)	Ground	Interior room lamp power supply	Output	After passing the interior room lamp battery saver operation time		0V
				Any other time after passing the interior room lamp battery saver operation time		Battery voltage
5 (G)	Ground	Front door RH UNLOCK	Output	Front door RH	UNLOCK (actuator is activated)	Battery voltage
					Other than UNLOCK (actuator is not activated)	0V
7 (R/W)	Ground	Step lamp	Output	Step lamp	ON	0V
					OFF	Battery voltage
8 (V)	Ground	All doors LOCK	Output	All doors	LOCK (actuator is activated)	Battery voltage
					Other than LOCK (actuator is not activated)	0V
9 (L)	Ground	Front door LH UNLOCK	Output	Front door LH	UNLOCK (actuator is activated)	Battery voltage
					Other than UNLOCK (actuator is not activated)	0V
10 (G)	Ground	Rear door RH and rear door LH UNLOCK	Output	Rear door RH and rear door LH	UNLOCK (actuator is activated)	Battery voltage
					Other than UNLOCK (actuator is not activated)	0V
11 (Y/R)	Ground	Battery power supply	Input	Ignition switch OFF		Battery voltage
13 (B)	Ground	Ground	—	Ignition switch ON		0V
14 (GR/W)	Ground	Engine switch (push switch) illumination ground	Input	Tail lamp	OFF	0V
					ON	<p>NOTE: When the illumination brightening/dimming level is in the neutral position</p>  <p style="text-align: right; font-size: small;">JSNIA0010GB</p>
15 (Y/L)	Ground	ACC indicator lamp	Output	Ignition switch	OFF	Battery voltage
					ACC or ON	0V

A
B
C
D
E
F
G
H
I
J
K
EXL
M
N
O
P

BCM (BODY CONTROL MODULE)

< ECU DIAGNOSIS >

[XENON TYPE]

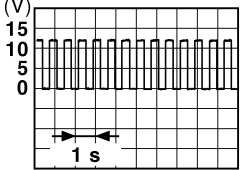
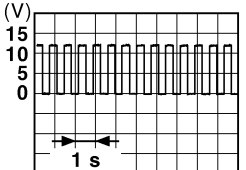
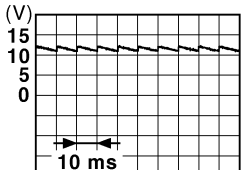
Terminal No. (Wire color)		Description		Condition		Value (Approx.)
(+)	(-)	Signal name	Input/ Output			
17 (G/B)	Ground	Turn signal (RH)	Output	Ignition switch ON	Turn signal switch OFF	0V
					Turn signal switch RH	 <p style="text-align: right; font-size: small;">PKID0926E 6.5 V</p>
18 (G/Y)	Ground	Turn signal (LH)	Output	Ignition switch ON	Turn signal switch OFF	0V
					Turn signal switch LH	 <p style="text-align: right; font-size: small;">PKID0926E 6.5 V</p>
19 (Y)	Ground	Room lamp timer control	Output	Interior room lamp	OFF	Battery voltage
					ON	0V
21 (P/B)	Ground	Optical sensor signal	Input	Ignition switch ON	When outside of the vehi- cle is bright	Close to 5V
					When outside of the vehi- cle is dark	Close to 0V
24 (R/W)	Ground	Stop lamp switch 1	Input	—	Battery voltage	
26 (O/L)	Ground	Stop lamp switch 2	Input	Stop lamp switch	OFF (brake pedal is re- leased)	0V
					ON (brake pedal is de- pressed)	Battery voltage
27 (O)	Ground	Front door lock as- sembly LH (unlock sensor)	Input	Front door LH	LOCK status	 <p style="text-align: right; font-size: small;">JPMIA0011GB 11.8V</p>
					UNLOCK status	0V
29 (Y)	Ground	Key slot switch	Input	When Intelligent Key is inserted into key slot	Battery voltage	
				When Intelligent Key is not inserted into key slot	0V	
30 (V/Y)	Ground	ACC feedback signal	Input	Ignition switch	OFF	0
				ACC or ON	Battery voltage	
31 (G)	Ground	Rear window defog- ger feedback signal	Input	Rear window de- fogger switch	OFF	0V
				ON	Battery voltage	

BCM (BODY CONTROL MODULE)

< ECU DIAGNOSIS >

[XENON TYPE]

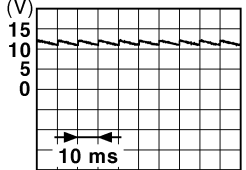
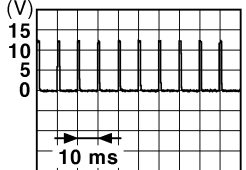
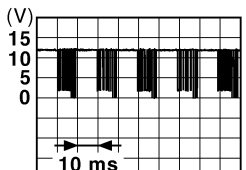

Terminal No. (Wire color)		Description		Condition		Value (Approx.)
(+)	(-)	Signal name	Input/ Output			
32 (R/B)	Ground	Front door RH switch	Input	Front door RH switch	OFF (when front door RH closes)	 11.8 V
					ON (when front door RH opens)	0V
37 (O)	Ground	Trunk lid opener cancel switch	Input	Trunk lid opener cancel switch	CANCEL	 1.1V
					ON	0V
38 (GR/W)	Ground	Rear window defogger ON signal	Input	Rear window defogger switch	OFF	5V
					ON	0V
40 (Y/G)	Ground	Power window serial link	Input/ Output	Ignition switch ON	 10.2V	
				Ignition switch OFF or ACC	0V	
41 (W)	Ground	Engine switch (push switch) illumination	Output	Engine switch (push switch) illumination	ON	5.5V
				OFF	0V	
42 (R)	Ground	LOCK indicator lamp	Output	LOCK indicator lamp	ON	0V
				OFF	Battery voltage	
45 (P)	Ground	Receiver & sensor ground	Input	Ignition switch ON	0V	N
46 (V/W)	Ground	Receiver & sensor power supply output	Output	Ignition switch	OFF	0V
				ACC or ON	5.0V	O

A
B
C
D
E
F
G
H
I
J
K
EXL
M
N
O
P

BCM (BODY CONTROL MODULE)

< ECU DIAGNOSIS >

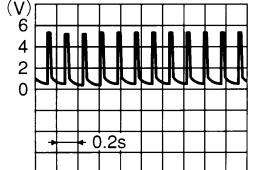
[XENON TYPE]

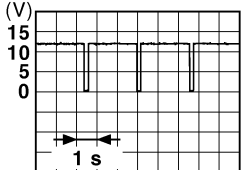
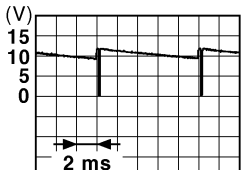
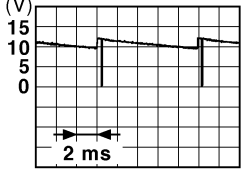
Terminal No. (Wire color)		Description		Condition	Value (Approx.)
(+)	(-)	Signal name	Input/ Output		
47 ¹ (G/O)	Ground	Tire pressure receiver signal	Input/ Output	Ignition switch ON	Standby state  OCC3881D
				When receiving the signal from the transmitter  OCC3880D	
48 (R/G)	Ground	Selector lever transmission range switch signal	Input	Selector lever	P or N position 12.0V
				Except P and N positions	0V
49 (L/O)	Ground	Security indicator signal	Output	Security indicator	ON 0V
				Blinking  11.3V JPMIA0014GB	
50 (LG/B)	Ground	Combination switch OUTPUT 5	Output	Combination switch (Wiper intermittent dial 4)	All switch OFF 0V
				Lighting switch 1ST	Lighting switch high-beam Lighting switch 2ND Turn signal switch RH  10.7V JPMIA0031GB
				Lighting switch high-beam	
				Lighting switch 2ND	
51 (L/W)	Ground	Combination switch OUTPUT 1	Output	Combination switch	All switch OFF (Wiper intermittent dial 4) 0V
				Any of the conditions below with all switch OFF • Wiper intermittent dial 1 • Wiper intermittent dial 2 • Wiper intermittent dial 3 • Wiper intermittent dial 6 • Wiper intermittent dial 7  10.7V JPMIA0032GB	

BCM (BODY CONTROL MODULE)

< ECU DIAGNOSIS >

[XENON TYPE]

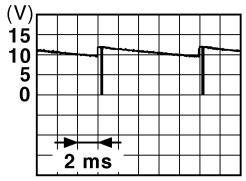
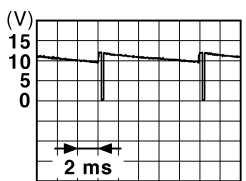
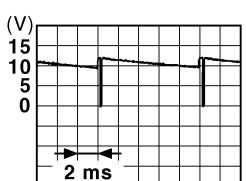
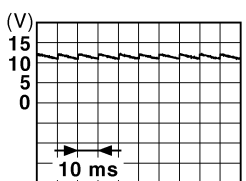
Terminal No. (Wire color)		Description		Condition	Value (Approx.)		
		Signal name	Input/ Output				
(+)	(-)						
52 (G/B)	Ground	Combination switch OUTPUT 2	Output	Combination switch	All switch OFF (Wiper intermittent dial 4)	0V	
					Front washer switch ON (Wiper intermittent dial 4)		
					Any of the conditions below with all switch OFF		
					<ul style="list-style-type: none"> • Wiper intermittent dial 1 • Wiper intermittent dial 5 • Wiper intermittent dial 6 		
					10.7V		
53 (LG/ R)	Ground	Combination switch OUTPUT 3	Output	Combination switch (Wiper intermit- tent dial 4)	All switch OFF	0V	
					Front wiper switch INT		
					Front wiper switch LO		
					Lighting switch AUTO		
					10.7V		
54 (G/Y)	Ground	Combination switch OUTPUT 4	Output	Combination switch (Wiper intermit- tent dial 4)	All switch OFF	0V	
					Front fog lamp switch ON		
					Lighting switch 2ND		
					Lighting switch flash-to- pass		
					10.7V		
57 ¹ (W)	Ground	Tire pressure warn- ing check switch	Input	—	5V		
58 (SB)	Ground	Front door LH switch	Input	Front door LH switch	OFF (front door LH CLOSE)		
					ON (front door LH OPEN)		0V
					11.8V		
59 (G/R)	Ground	Rear window defog- ger relay	Output	Rear window de- fogger	Active	Battery voltage	
					Not activated	0V	

A
B
C
D
E
F
G
H
I
J
K
EXL
M
N
O
P

BCM (BODY CONTROL MODULE)

< ECU DIAGNOSIS >

[XENON TYPE]

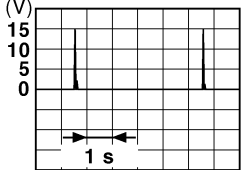
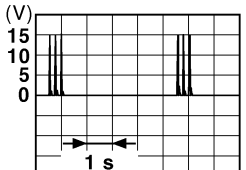
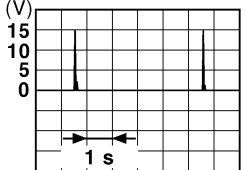
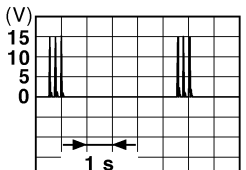
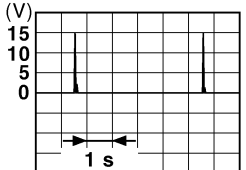
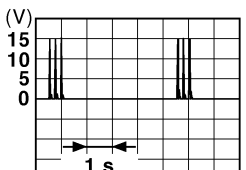
Terminal No. (Wire color)		Description		Condition	Value (Approx.)
(+)	(-)	Signal name	Input/ Output		
60 (B/R)	Ground	Front console antenna 2 (-)	Output	Ignition switch OFF	 <p style="text-align: right; font-size: small;">JMKIA0062GB</p>
				When Intelligent Key is not in the passenger compartment	 <p style="text-align: right; font-size: small;">JMKIA0063GB</p>
61 (W/R)	Ground	Center console antenna 2 (+)	Output	Ignition switch OFF	 <p style="text-align: right; font-size: small;">JMKIA0062GB</p>
				When Intelligent Key is not in the passenger compartment	 <p style="text-align: right; font-size: small;">JMKIA0063GB</p>
62 (V)	Ground	Front outside handle RH antenna (-)	Output	When the front door RH request switch is operated with ignition switch OFF	 <p style="text-align: right; font-size: small;">JMKIA0062GB</p>
				When Intelligent Key is not in the antenna detection area	 <p style="text-align: right; font-size: small;">JMKIA0063GB</p>

BCM (BODY CONTROL MODULE)

< ECU DIAGNOSIS >

[XENON TYPE]

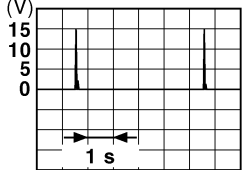
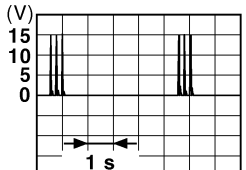
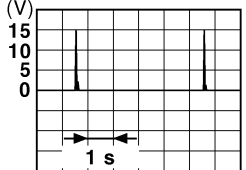
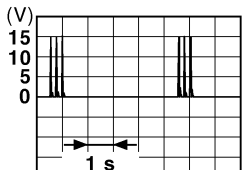
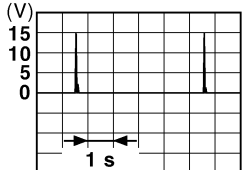
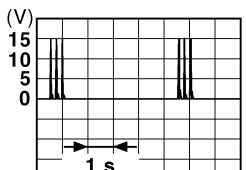



Terminal No. (Wire color)		Description		Condition	Value (Approx.)
(+)	(-)	Signal name	Input/ Output		
63 (P)	Ground	Front outside handle RH antenna (+)	Output	When the front door RH request switch is operat- ed with ignition switch OFF	When Intelligent Key is in the antenna detection area  <small>JMKIA0062GB</small>
				When Intelligent Key is not in the antenna detection area	 <small>JMKIA0063GB</small>
64 (V)	Ground	Front outside handle LH antenna (-)	Output	When the front door LH request switch is operat- ed with ignition switch OFF	When Intelligent Key is in the antenna detection area  <small>JMKIA0062GB</small>
				When Intelligent Key is not in the antenna detection area	 <small>JMKIA0063GB</small>
65 (P)	Ground	Front outside handle LH antenna (+)	Output	When the front door LH request switch is operat- ed with ignition switch OFF	When Intelligent Key is in the antenna detection area  <small>JMKIA0062GB</small>
				When Intelligent Key is not in the antenna detection area	 <small>JMKIA0063GB</small>

A
B
C
D
E
F
G
H
I
J
K
EXL
M
N
O
P

BCM (BODY CONTROL MODULE)

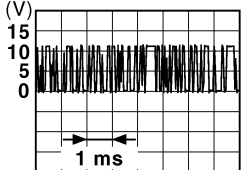
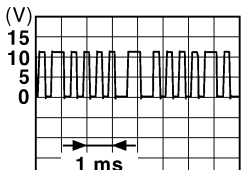
< ECU DIAGNOSIS >



[XENON TYPE]

Terminal No. (Wire color)		Description		Condition		Value (Approx.)
(+)	(-)	Signal name	Input/ Output			
68 (G/O)	Ground	NATS antenna amp (built in key slot)	Input/ Output	During waiting	Ignition switch is pressed while inserting the Intelli- gent Key into the key slot.	Just after pressing ignition switch. Pointer of tester should move.
69 (O)	Ground	NATS antenna amp (built in key slot)	Input/ Output	During waiting	Ignition switch is pressed while inserting the Intelli- gent Key into the key slot.	Just after pressing ignition switch. Pointer of tester should move.
70 (R/B)	Ground	Ignition relay-2 con- trol	Output	Ignition switch	OFF or ACC ON	0V Battery voltage
71 (L/O)	Ground	Remote keyless entry receiver signal	Input/ Output	During waiting		 <p style="text-align: right; font-size: small;">JMKIA0064GB</p>
				When operating either button on Intelligent Key		 <p style="text-align: right; font-size: small;">JMKIA0065GB</p>
75 (R/Y)	Ground	Combination switch INPUT 5	Input	Combination switch	All switch OFF (Wiper intermittent dial 4)	 <p style="text-align: right; font-size: small;">JPMIA0041GB</p> <p style="text-align: center;">1.4V</p>
					Front fog lamp switch ON (Wiper intermittent dial 4)	 <p style="text-align: right; font-size: small;">JPMIA0037GB</p> <p style="text-align: center;">1.3V</p>
					Any of the conditions below with all switch OFF • Wiper intermittent dial 1 • Wiper intermittent dial 2 • Wiper intermittent dial 6 • Wiper intermittent dial 7	 <p style="text-align: right; font-size: small;">JPMIA0040GB</p> <p style="text-align: center;">1.3V</p>

BCM (BODY CONTROL MODULE)

< ECU DIAGNOSIS >

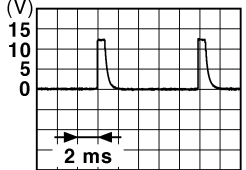
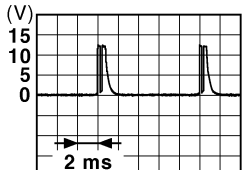
[XENON TYPE]

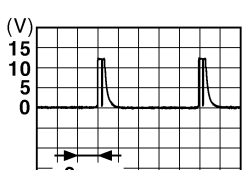
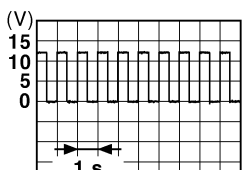
Terminal No. (Wire color)		Description		Condition	Value (Approx.)	
(+)	(-)	Signal name	Input/ Output			
76 (R/G)	Ground	Combination switch INPUT 3	Input	Combination switch	All switch OFF (Wiper intermittent dial 4)	 <small>JPMIA0041GB</small> 1.4V
					Lighting switch high-beam (Wiper intermittent dial 4)	 <small>JPMIA0036GB</small> 1.3V
					Lighting switch 2ND (Wiper intermittent dial 4)	 <small>JPMIA0037GB</small> 1.3V
					Any of the conditions below with all switch OFF • Wiper intermittent dial 1 • Wiper intermittent dial 2 • Wiper intermittent dial 3	 <small>JPMIA0040GB</small> 1.3V
77 ² (BR)	Ground	Engine switch (push switch)	Input	Engine switch (push switch)	Pressed Not pressed	0V Battery voltage
78 (P)	Ground	CAN-L	Input/ Output	—	—	
79 (L)	Ground	CAN-H	Input/ Output	—	—	
80 (R/L)	Ground	Key slot illumination	Output	Key slot illumina- tion	OFF	0V
					Blinking	 <small>JPMIA0015GB</small> 6.5V
					ON	Battery voltage

A
B
C
D
E
F
G
H
I
J
K

EXL

M
N
O
P

BCM (BODY CONTROL MODULE)

< ECU DIAGNOSIS >



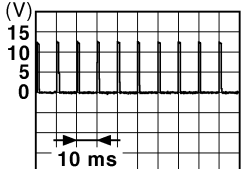
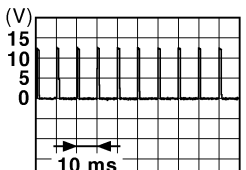

[XENON TYPE]

Terminal No. (Wire color)		Description		Condition		Value (Approx.)
		Signal name	Input/ Output			
(+)	(-)					
81 (LG)	Ground	ON indicator lamp	Output	Ignition switch	OFF or ACC	0V
					ON	Battery voltage
83 (L)	Ground	ACC relay control	Output	Ignition switch	OFF	0V
					ACC or ON	Battery voltage
84 (Y/R)	Ground	CVT shift selector	Output	—		Battery voltage
85 ³ (L/O)	Ground	Electronic steering column lock condition No. 1	Input	Electronic steer- ing column lock	Lock status	0V
					Unlock status	Battery voltage
86 ³ (G/R)	Ground	Electronic steering column lock condition No. 2	Input	Electronic steer- ing column lock	Lock status	Battery voltage
					Unlock status	0V
87 (G/B)	Ground	Selector lever P posi- tion switch	Input	Selector lever	P position	0V
					Any position other than P	Battery voltage
88 (R)	Ground	Front door RH re- quest switch	Input	Front door RH re- quest switch	ON (pressed)	0V
					OFF (not pressed)	
89 (R)	Ground	Front door LH re- quest switch	Input	Front door LH re- quest switch	ON (pressed)	0V
					OFF (not pressed)	
90 (Y)	Ground	Blower fan motor re- lay control	Output	Ignition switch	OFF or ACC	0V
					ON	Battery voltage
91 (L/R)	Ground	Remote keyless entry receiver power sup- ply	Output	Ignition switch OFF		Battery voltage
94 ³ (G/Y)	Ground	Steering wheel lock unit power supply	Output	Ignition switch	OFF or ACC	Battery voltage
					ON	0V

BCM (BODY CONTROL MODULE)

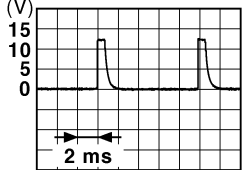
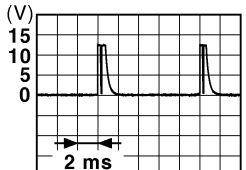
< ECU DIAGNOSIS >

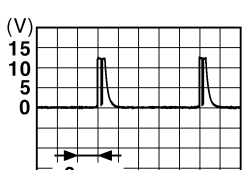
[XENON TYPE]

Terminal No. (Wire color)		Description		Condition	Value (Approx.)
(+)	(-)	Signal name	Input/ Output		
95 (R/W)	Ground	Combination switch INPUT 1	Input	All switch OFF	 <small>JPMIA0041GB</small> 1.4V
				Turn signal switch LH	 <small>JPMIA0037GB</small> 1.3V
				Turn signal switch RH	 <small>JPMIA0036GB</small> 1.3V
				Front wiper switch LO	 <small>JPMIA0038GB</small> 1.3V
				Front washer switch ON	 <small>JPMIA0039GB</small> 1.3V

A
B
C
D
E
F
G
H
I
J
K
EXL
M
N
O
P

BCM (BODY CONTROL MODULE)

< ECU DIAGNOSIS >



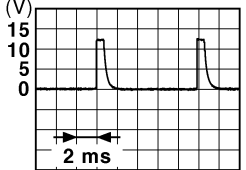
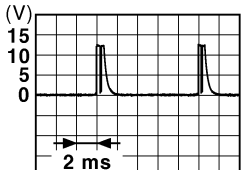
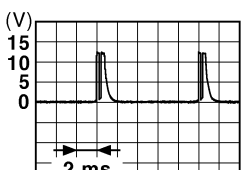
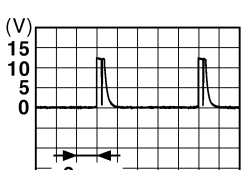

[XENON TYPE]

Terminal No. (Wire color)		Description		Condition	Value (Approx.)
(+)	(-)	Signal name	Input/ Output		
96 (P/B)	Ground	Combination switch INPUT 4	Input	Combination switch	All switch OFF (Wiper intermittent dial 4) <div style="text-align: right;">  <p style="font-size: small; margin: 0;">JPMIA0041GB</p> <p style="margin: 0;">1.4V</p> </div>
				Lighting switch AUTO (Wiper intermittent dial 4)	<div style="text-align: right;">  <p style="font-size: small; margin: 0;">JPMIA0038GB</p> <p style="margin: 0;">1.3V</p> </div>
				Lighting switch 1ST (Wiper intermittent dial 4)	<div style="text-align: right;">  <p style="font-size: small; margin: 0;">JPMIA0036GB</p> <p style="margin: 0;">1.3V</p> </div>
				Any of the conditions below with all switch OFF	<div style="text-align: right;">  <p style="font-size: small; margin: 0;">JPMIA0039GB</p> <p style="margin: 0;">1.3V</p> </div>

BCM (BODY CONTROL MODULE)

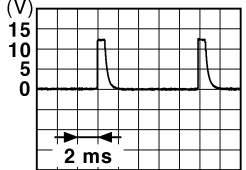
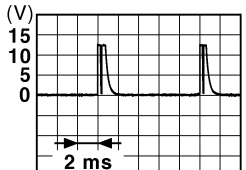
< ECU DIAGNOSIS >

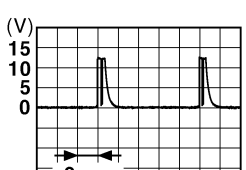
[XENON TYPE]

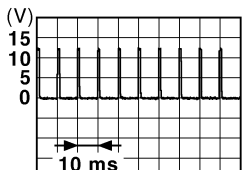
Terminal No. (Wire color)		Description		Condition	Value (Approx.)	
(+)	(-)	Signal name	Input/ Output			
97 (R/B)	Ground	Combination switch INPUT 2	Input	Combination switch (Wiper intermittent dial 4)	All switch OFF	 1.4V
					Lighting switch flash-to-pass	 1.3V
					Lighting switch 2ND	 1.3V
					Front wiper switch INT	 1.3V
					Front wiper switch HI	 1.3V
					Pressed	0 V
98 (G/O)	Ground	Hazard switch	Input	Hazard switch	Not pressed	 1.1V

A
B
C
D
E
F
G
H
I
J
K
EXL
M
N
O
P

BCM (BODY CONTROL MODULE)

< ECU DIAGNOSIS >

[XENON TYPE]

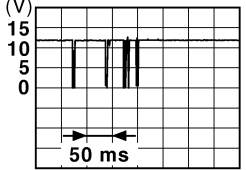
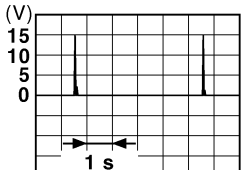
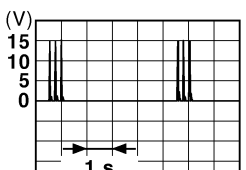
Terminal No. (Wire color)		Description		Condition	Value (Approx.)	
(+)	(-)	Signal name	Input/ Output			
99 ³ (L/Y)	Ground	Electronic steering column lock unit com- munication	Input/ Output	Electronic steer- ing column lock	LOCK status	Battery voltage
					LOCK or UNLOCK	 <p style="text-align: right; font-size: small;">JMKIA0066GB</p>
					For 15 seconds after UN- LOCK	Battery voltage
					15 seconds or later after UNLOCK	0V
103 (V)	Ground	Trunk lid opening.	Output	Trunk lid	Open (trunk lid opener ac- tuator is activated)	Battery voltage
					Close (trunk lid opener ac- tuator is not activated)	0V
110 (V/W)	Ground	Trunk room lamp	Output	Trunk room lamp	ON	0V
					OFF	Battery voltage
114 (B)	Ground	Trunk room antenna 1 (-)	Output	Ignition switch OFF	When Intelligent Key is in the passenger compart- ment	 <p style="text-align: right; font-size: small;">JMKIA0062GB</p>
					When Intelligent Key is not in the passenger compart- ment	 <p style="text-align: right; font-size: small;">JMKIA0063GB</p>

BCM (BODY CONTROL MODULE)

< ECU DIAGNOSIS >

[XENON TYPE]

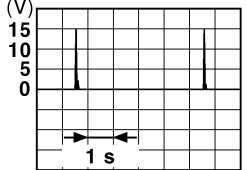
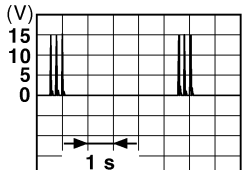
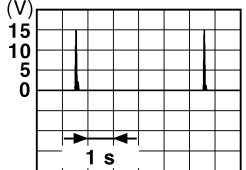
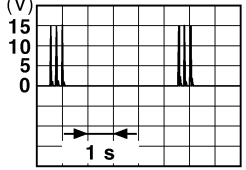
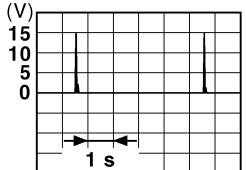
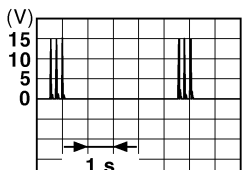
Terminal No. (Wire color)		Description		Condition	Value (Approx.)
(+)	(-)	Signal name	Input/ Output		
115 (W)	Ground	Trunk room antenna 1 (+)	Output	Ignition switch OFF	 <p style="text-align: right; font-size: small;">JMKIA0062GB</p>
				When Intelligent Key is not in the passenger compart- ment	 <p style="text-align: right; font-size: small;">JMKIA0063GB</p>
118 (L/O)	Ground	Rear bumper anten- na (-)	Output	When the trunk lid request switch is operated with ignition switch OFF	 <p style="text-align: right; font-size: small;">JMKIA0062GB</p>
				When Intelligent Key is not in the antenna detection area	 <p style="text-align: right; font-size: small;">JMKIA0063GB</p>
119 (BR/ W)	Ground	Rear bumper anten- na (+)	Output	When the trunk lid request switch is operated with ignition switch OFF	 <p style="text-align: right; font-size: small;">JMKIA0062GB</p>
				When Intelligent Key is not in the antenna detection area	 <p style="text-align: right; font-size: small;">JMKIA0063GB</p>

A
B
C
D
E
F
G
H
I
J
K
M
N
O
P

EXL

BCM (BODY CONTROL MODULE)

< ECU DIAGNOSIS >

[XENON TYPE]

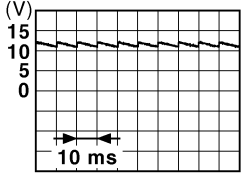
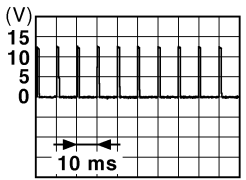
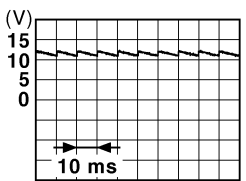
Terminal No. (Wire color)		Description		Condition		Value (Approx.)
(+)	(-)	Signal name	Input/ Output			
127 (BR/ W)	Ground	Ignition relay (IPDM E/R) control	Output	Ignition switch	OFF or ACC	Battery voltage
					ON	0V
130 (W)	Ground	Trunk room lamp switch	Input	Trunk room lamp switch	OFF (trunk is closed)	 <p style="text-align: right; font-size: small;">JPMIA0011GB</p> <p style="text-align: center;">11.8V</p>
					ON (trunk is open)	0V
132 (R)	Ground	Starter motor relay control	Output	Ignition switch ON	When selector lever is in P or N position and the brake is depressed	Battery voltage
					When selector lever is in P or N position and the brake is not depressed	0V
140 ⁴ (L/R)	Ground	Engine switch (push switch)	Input	Engine switch (push switch)	Pressed	0V
					Not pressed	Battery voltage
141 (BR)	Ground	Trunk request switch	Input	Trunk request switch	ON (pressed)	0V
					OFF (not pressed)	 <p style="text-align: right; font-size: small;">JPMIA0016GB</p> <p style="text-align: center;">1.0V</p>
144 (GR)	Ground	Request switch buzz- er	Output	Request switch buzzer	Sounding	0V
					Not sounding	Battery voltage
147 (L/R)	Ground	Trunk lid opener switch	Input	Trunk lid opener switch	Pressed	0V
					Not pressed	Battery voltage
148 (R/W)	Ground	Rear door RH switch	Input	Rear door RH switch	OFF (when rear door RH closes)	 <p style="text-align: right; font-size: small;">JPMIA0011GB</p> <p style="text-align: center;">11.8V</p>
					ON (when rear door RH opens)	0V

BCM (BODY CONTROL MODULE)

< ECU DIAGNOSIS >

[XENON TYPE]

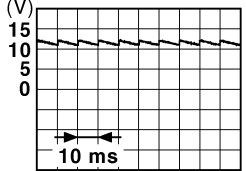
Terminal No. (Wire color)		Description		Condition	Value (Approx.)	
		Signal name	Input/ Output			
(+)	(-)					
149 (R/B)	Ground	Rear door LH switch	Input	Rear door LH switch	OFF (when rear door LH closes)	
				ON (when rear door LH opens)	0V	

- 1 : With low tire pressure monitoring system
- 2 : With electronic steering column lock
- 3 : Early production
- 4 : Without electronic steering column lock

A
B
C
D
E
F
G
H
I
J
K

EXL

M
N
O
P

BCM (BODY CONTROL MODULE)

< ECU DIAGNOSIS >

[XENON TYPE]

Wiring Diagram

INFOID:000000005530149

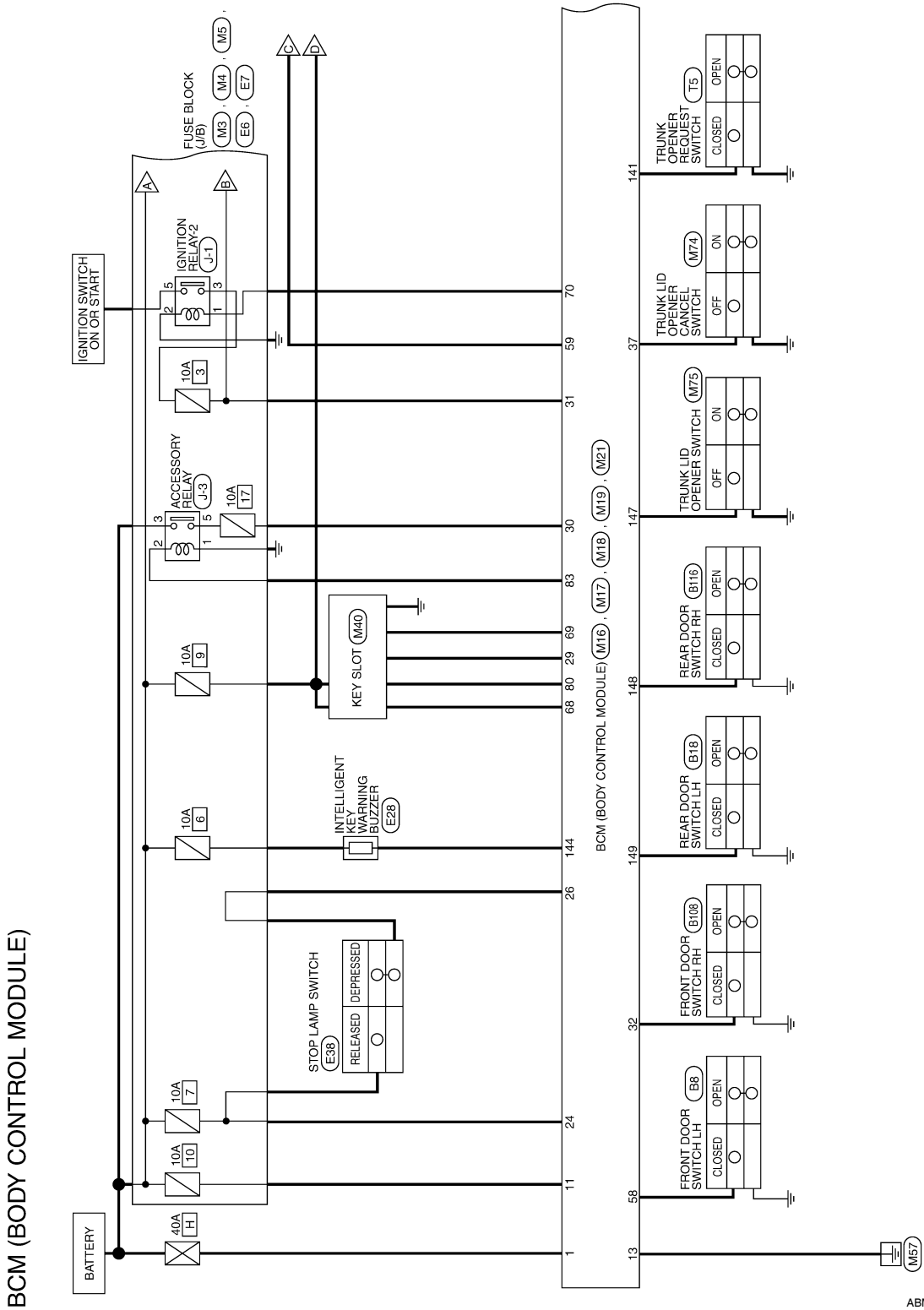

ABMWA0498G

BCM (BODY CONTROL MODULE)

< ECU DIAGNOSIS >

[XENON TYPE]

- ◊TP◊ : WITH LOW TIRE PRESSURE MONITORING SYSTEM
- ◊EH◊ : WITH ELECTRONIC STEERING COLUMN LOCK
- ◊EJ◊ : WITHOUT ELECTRONIC STEERING COLUMN LOCK

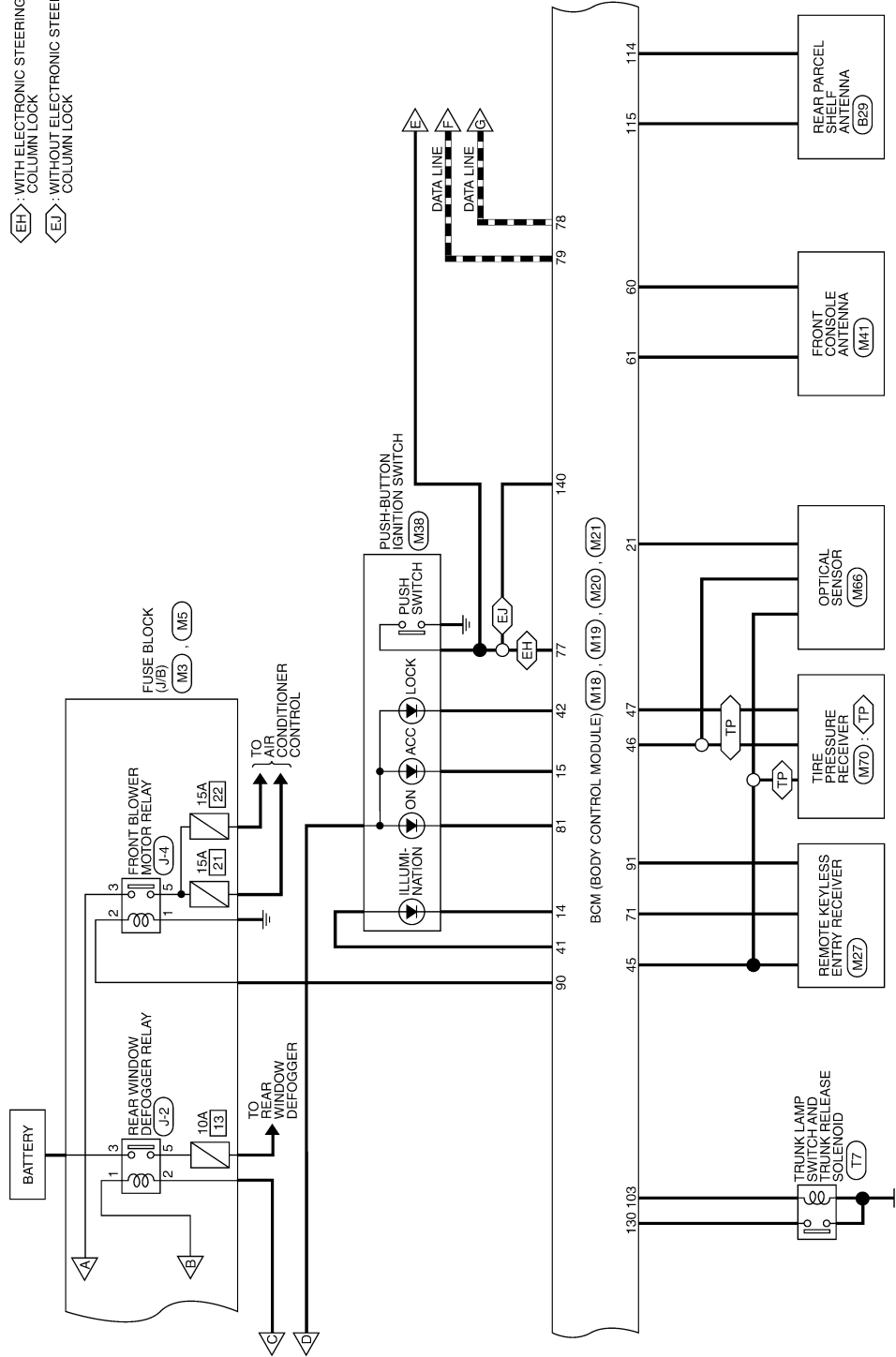

ABMWA0817GI

A
B
C
D
E
F
G
H
I
J
K
EXL
M
N
O
P

BCM (BODY CONTROL MODULE)

< ECU DIAGNOSIS >

[XENON TYPE]

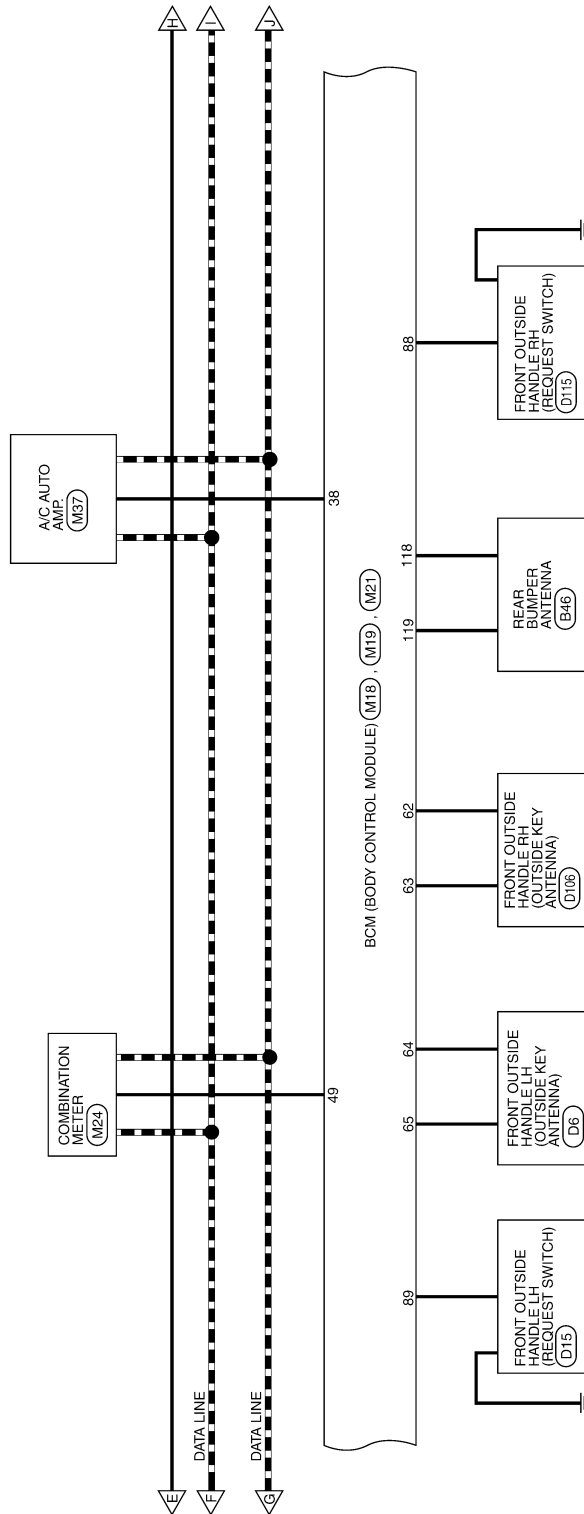

ABMWA0818GI

BCM (BODY CONTROL MODULE)

< ECU DIAGNOSIS >

[XENON TYPE]

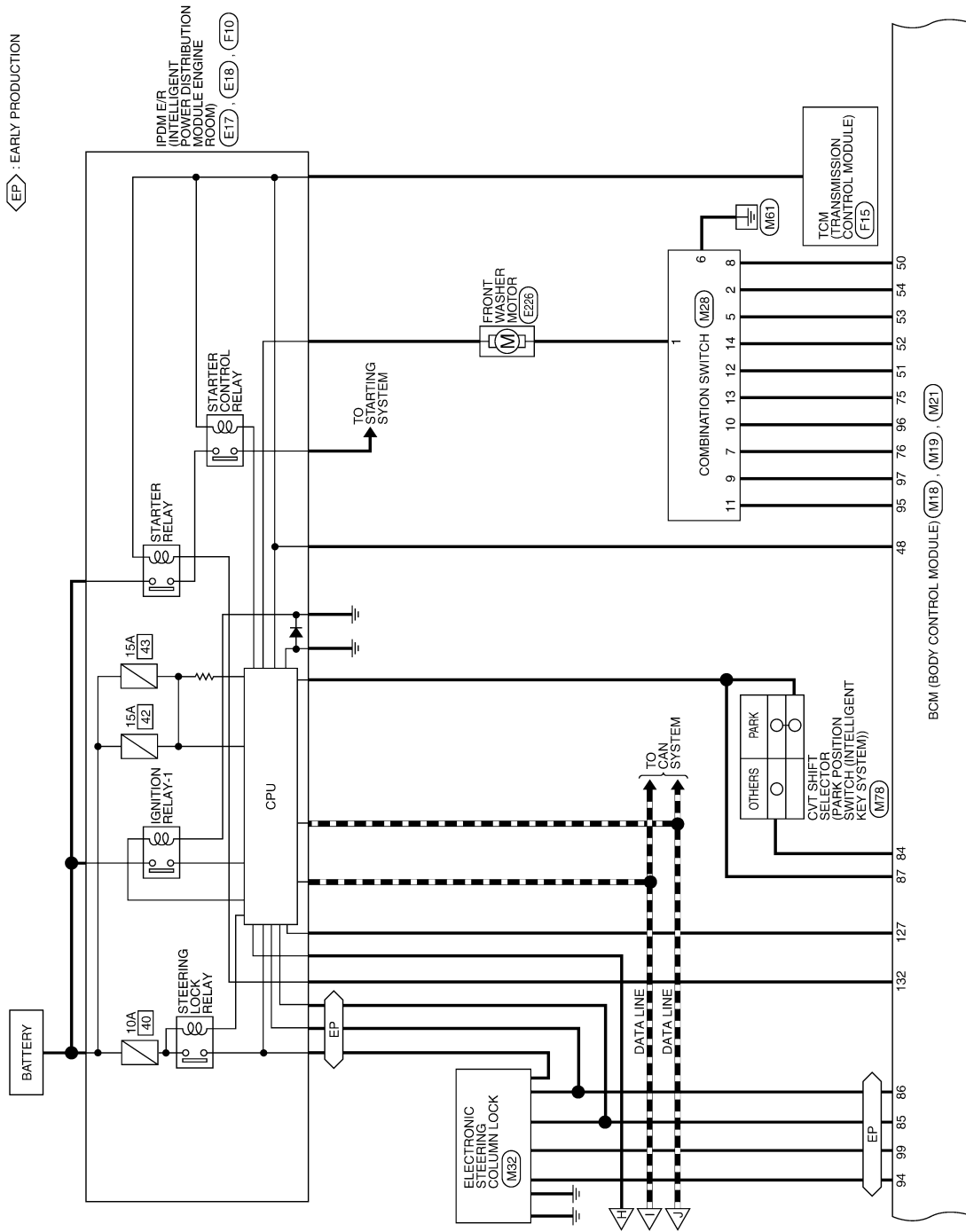

ABMWA0819GI

A
B
C
D
E
F
G
H
I
J
K
EXL
M
N
O
P

BCM (BODY CONTROL MODULE)

[XENON TYPE]

< ECU DIAGNOSIS >

- $\langle A2 \rangle$: WITH LEFT AND RIGHT FRONT POWER WINDOW ANTI-PINCH SYSTEM
- $\langle A3 \rangle$: WITH FRONT AND REAR POWER WINDOW ANTI-PINCH SYSTEM
- $\langle DP \rangle$: WITH DUAL PANEL SUNROOF
- $\langle DW \rangle$: WITHOUT DUAL PANEL SUNROOF

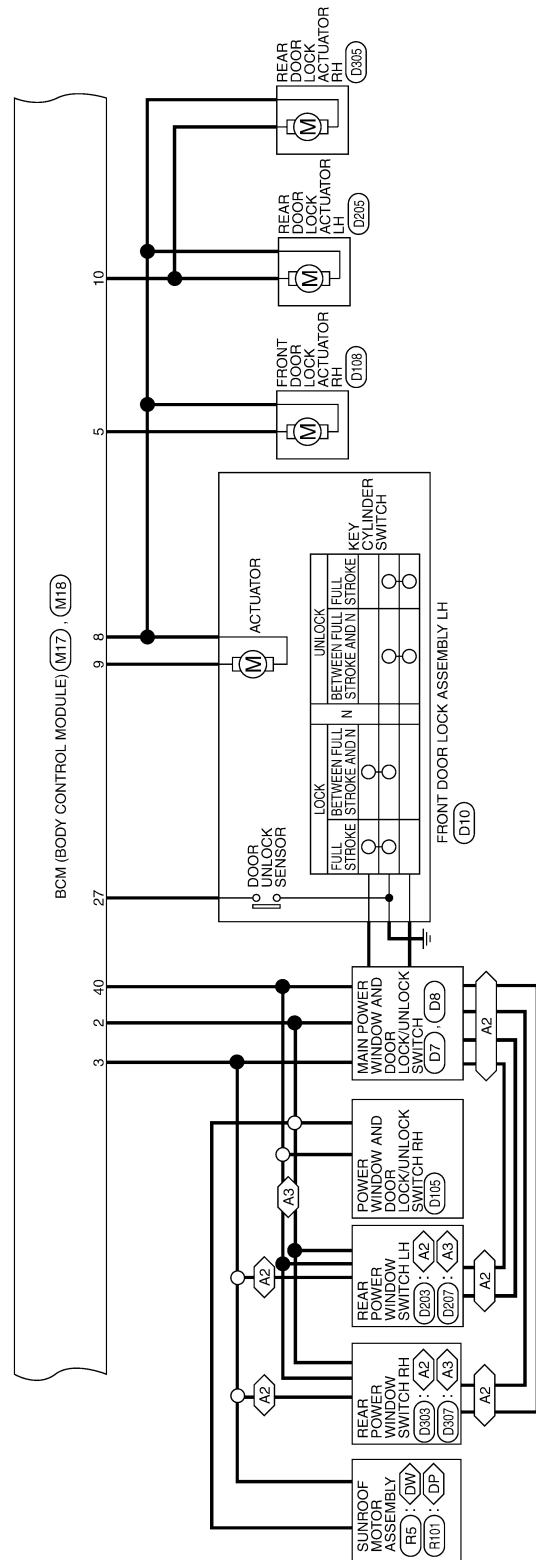

ABMWA0081GI

BCM (BODY CONTROL MODULE)

< ECU DIAGNOSIS >

[XENON TYPE]

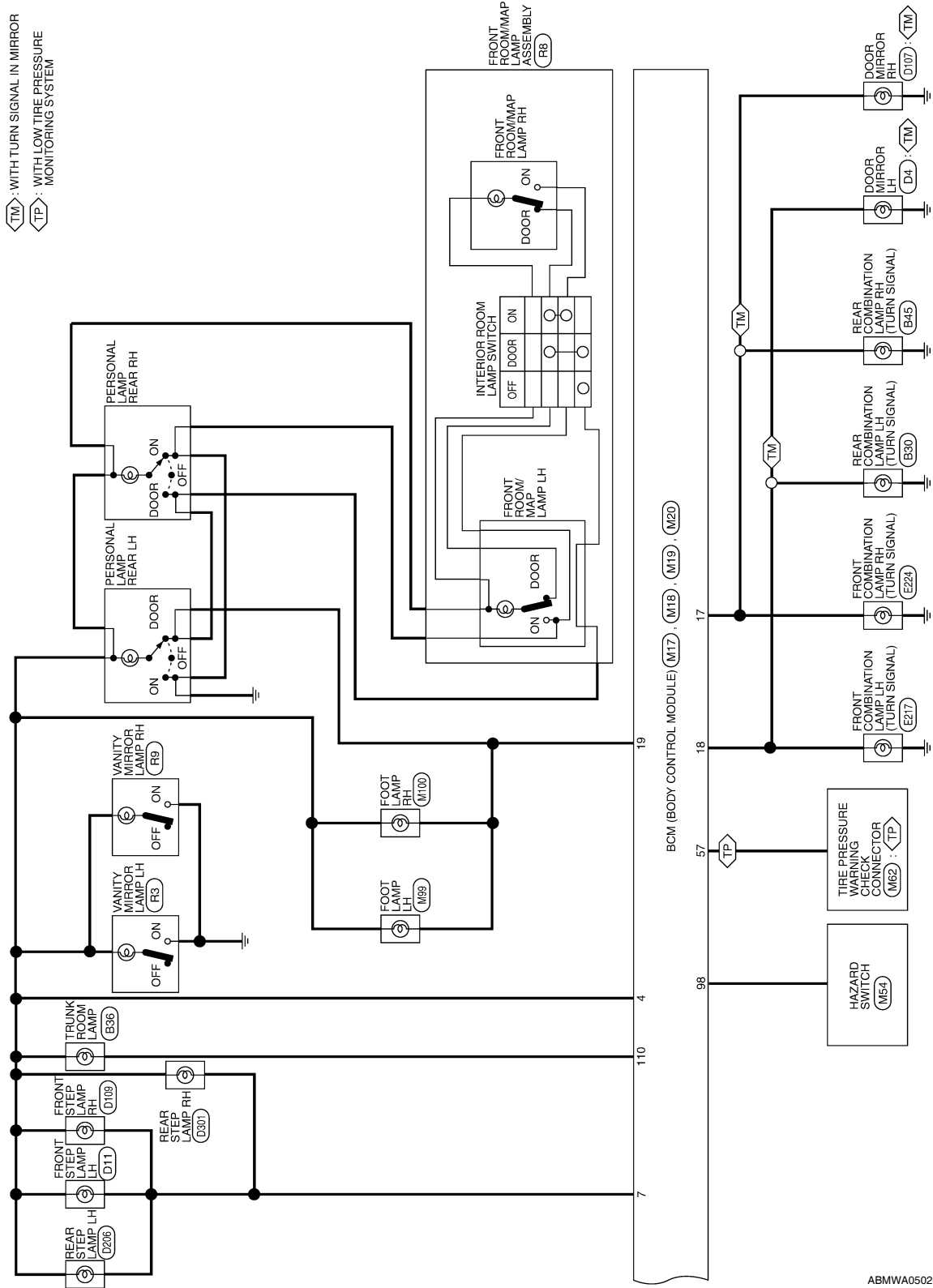

A
B
C
D
E
F
G
H
I
J
K
EXL
M
N
O
P

BCM (BODY CONTROL MODULE)

< ECU DIAGNOSIS >

[XENON TYPE]

BCM (BODY CONTROL MODULE) CONNECTORS

Connector No.	M16
Connector Name	BCM (BODY CONTROL MODULE)
Connector Color	BLACK



Terminal No.	Color of Wire	Signal Name
1	W/B	BATT (F/L)
2	R/Y	P/W POWER SUPPLY PERM
3	L/W	P/W POWER SUPPLY IGN

Connector No.	M17
Connector Name	BCM (BODY CONTROL MODULE)
Connector Color	WHITE

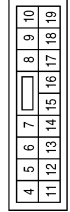

Terminal No.	Color of Wire	Signal Name
4	P/W	R/L POWER SUPPLY
5	G	DOOR UNLOCK OUTPUT AS
6	-	-
7	R/W	STEP LAMP CONT
8	V	DOOR LOCK OUTPUT ALL
9	L	DOOR UNLOCK OUTPUT (DR/FL)

Terminal No.	Color of Wire	Signal Name
10	G	DOOR UNLOCK OUTPUT (RR/RL)
11	Y/R	BAT BCM FUSE
12	-	-
13	B	GND1
14	GR/W	LOW SIDE PUSH LED
15	Y/L	ACC LED
16	-	-
17	G/B	FR FLASHER
18	G/Y	FL FLASHER
19	Y	ROOM LAMP CONT

Connector No.	M18
Connector Name	BCM (BODY CONTROL MODULE)
Connector Color	GREEN

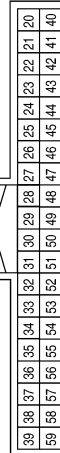

Terminal No.	Color of Wire	Signal Name
20	-	-
21	P/B	A/L SIGNAL TYPE 1
22	-	-
23	-	-
24	R/W	BRAKE SW1
25	-	-
26	O/L	BRAKE SW2

Terminal No.	Color of Wire	Signal Name
27	O	DOOR LOCK STATUS DR
28	-	-
29	Y	FOB IN SW 1
30	V/Y	ACC F/B
31	G	IGN F/B
32	R/B	AS DOOR SW 1
33	-	-
34	-	-
35	-	-
36	-	-
37	O	TRUNK CANCEL SW
38	GR/W	REAR DEFOGGER SW
39	-	-
40	Y/G	PW K-LINE
41	W	RING LED
42	R	S/L LOCK LED
43	-	-
44	-	-

Terminal No.	Color of Wire	Signal Name
45	P	GND RF2 A/L
46	V/W	A/L POWER SUPPLY 5V
47	G/O	RF2 TUNER SIGNAL
48	R/G	SHIFT N/P/ NEUTRAL SW
49	L/O	IMMO LED (SECURITY INDICATOR)
50	LG/B	OUTPUT 5
51	L/W	OUTPUT 1
52	G/B	OUTPUT 2
53	LG/R	OUTPUT 3
54	G/Y	OUTPUT 4
55	-	-
56	-	-
57	W	TPMS MODE
58	SB	DR DOOR SW
59	G/R	REAR DEFOGGER

ABMIA1331GB

BCM (BODY CONTROL MODULE)

< ECU DIAGNOSIS >

[XENON TYPE]

Terminal No.	Color of Wire	Signal Name
84	Y/R	AT DEVICE OUT
85	L/O	S/L CONDITION 1
86	G/R	S/L CONDITION 2
87	G/B	SHIFT P/ASCD CANCEL SW
88	R	AS REQUEST SW
89	R	DR REQUEST SW
90	Y	BLOWER FAN RELAY
91	L/R	RF POWER SUPPLY 12V
92	-	-
93	-	-
94	G/Y	S/L POWER SUPPLY 12V
95	R/W	INPUT 1
96	P/B	INPUT 4
97	R/B	INPUT 2
98	G/O	HAZARD SW
99	L/Y	S/L K-LINE

Terminal No.	Color of Wire	Signal Name
67	-	-
68	G/O	FOB READER CLOCK
69	O	FOB READER DATA
70	R/B	IGN REL OUTPUT 2
71	L/O	RF1 TUNER SIGNAL
72	-	-
73	-	-
74	-	-
75	R/Y	INPUT 5
76	R/G	INPUT 3
77	BR	ENG START SW
78	P	CAN-L
79	L	CAN-H
80	R/L	FOB SLOT ILLUMINATION
81	LG	IGN ON LED
82	-	-
83	L	ACC CONT

Connector No.	M19
Connector Name	BCM (BODY CONTROL MODULE)
Connector Color	BLACK



79	78	77	76	75	74	73	72	71	70	69	68	67	66	65	64	63	62	61	60
59	58	57	56	55	54	53	52	51	50	49	48	47	46	45	44	43	42	41	40

Terminal No.	Color of Wire	Signal Name
60	B/R	ROOM ANT 2 B
61	W/R	ROOM ANT 2 A
62	V	AS DOOR ANT B
63	P	AS DOOR ANT A
64	V	DR DOOR ANT B
65	P	DR DOOR ANT A
66	-	-

Connector No.	M20
Connector Name	BCM (BODY CONTROL MODULE)
Connector Color	WHITE



100	101	102	103	104		
105	106	107	108	109	110	111

Terminal No.	Color of Wire	Signal Name
100	-	-
101	-	-
102	-	-
103	V	CDL BACK TRUNK

Terminal No.	Color of Wire	Signal Name
104	-	-
105	-	-
106	-	-
107	-	-
108	-	-
109	-	-
110	V/W	TRUNK LAMP CONT
111	-	-

ABMIA1332GB

A
B
C
D
E
F
G
H
I
J
K
L
M
N
O
P

EXL

BCM (BODY CONTROL MODULE)

< ECU DIAGNOSIS >

[XENON TYPE]

Terminal No.	Color of Wire	Signal Name
136	-	-
137	-	-
138	-	-
139	-	-
140	BR	ENG START SW W/O ESCL
141	BR	TRUNK REQUEST SW
142	-	-
143	-	-
144	GR	BUZZER
145	-	-
146	-	-
147	L/R	BACK TRUNK OPENER
148	R/W	RR DOOR SW
149	R/B	RL DOOR SW
150	-	-
151	-	-

Terminal No.	Color of Wire	Signal Name
119	BR/W	BACK DOOR ANT A
120	-	-
121	-	-
122	-	-
123	-	-
124	-	-
125	-	-
126	-	-
127	BR/W	IGN RELAY OUTPUT
128	-	-
129	-	-
130	W	TRUNK SW
131	-	-
132	R	ST RELAY OUTPUT
133	-	-
134	-	-
135	-	-

Terminal No.	Color of Wire	Signal Name
10	P/B	INPUT 4
11	R/W	INPUT 1
12	L/W	OUTPUT 1
13	R/Y	INPUT 5
14	G/B	OUTPUT 2

Connector No.	M21
Connector Name	BCM (BODY CONTROL MODULE)
Connector Color	GRAY

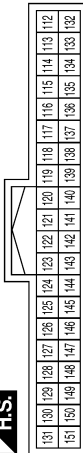

Terminal No.	Color of Wire	Signal Name
112	-	-
113	-	-
114	B	TRUNK ANT 1 B
115	W	TRUNK ANT 1 A
116	-	-
117	-	-
118	L/O	BACK DOOR ANT B

Connector No.	M28
Connector Name	COMBINATION SWITCH
Connector Color	WHITE



Terminal No.	Color of Wire	Signal Name
1	R/L	-
2	G/Y	OUTPUT 4
5	LG/R	OUTPUT 3
6	B	-
7	R/G	INPUT 3
8	LG/B	OUTPUT 5
9	R/B	INPUT 2

ABMIA2102GB

INFOID:000000005530150

Fail Safe

Display contents of CONSULT	Fail-safe	Cancellation
B2013: ID DISCORD BCM-S/L*	Inhibit engine cranking	Erase DTC
B2014: CHAIN OF S/L-BCM*	Inhibit engine cranking	Erase DTC
B2190: NATS ANTENNA AMP	Inhibit engine cranking	Erase DTC

BCM (BODY CONTROL MODULE)

[XENON TYPE]

< ECU DIAGNOSIS >

Display contents of CONSULT	Fail-safe	Cancellation	
B2191: DIFFERENCE OF KEY	Inhibit engine cranking	Erase DTC	A
B2192: ID DISCORD BCM-ECM	Inhibit engine cranking	Erase DTC	
B2193: CHAIN OF BCM-ECM	Inhibit engine cranking	Erase DTC	B
B2195: ANTI-SCANNING	Inhibit engine cranking	Erase DTC	
B2557: VEHICLE SPEED*	Inhibit electronic steering column lock	When normal vehicle speed signals have been received from ABS actuator and electric unit (control unit) for 500 ms	C
B2560: STARTER CONT RELAY	Inhibit engine cranking	500 ms after the following CAN signal communication status has become consistent <ul style="list-style-type: none"> • Starter control relay signal • Starter relay status signal 	D
B2562: LO VOLTAGE	<ul style="list-style-type: none"> • Inhibit engine cranking • Inhibit electronic steering column lock* 	100 ms after the power supply voltage increases to more than 8.8 V	E
B2601: SHIFT POSITION*	Inhibit electronic steering column lock	500 ms after the following signal reception status becomes consistent <ul style="list-style-type: none"> • Selector lever P position switch signal • P range signal (CAN) 	F
B2602: SHIFT POSITION*	Inhibit electronic steering column lock	5 seconds after the following BCM recognition conditions are fulfilled <ul style="list-style-type: none"> • Ignition switch is in the ON position • Selector lever P position switch signal: Except P position (battery voltage) • Vehicle speed: 4 km/h or more 	G
B2603: SHIFT POSI STATUS*	Inhibit electronic steering column lock	500 ms after the following BCM recognition conditions are fulfilled <ul style="list-style-type: none"> • Ignition switch is in the ON position • Selector lever P position switch signal: Except P position (battery voltage) • Selector lever transmission range switch signal: Except P and N positions (0 V) 	H
B2604: TRANSMISSION RANGE SWITCH*	Inhibit electronic steering column lock	500 ms after any of the following BCM recognition conditions is fulfilled <ul style="list-style-type: none"> • Status 1 <ul style="list-style-type: none"> - Ignition switch is in the ON position - Selector lever transmission range switch signal: P and N position (battery voltage) - P range signal or N range signal (CAN): ON • Status 2 <ul style="list-style-type: none"> - Ignition switch is in the ON position - Selector lever transmission range switch signal: Except P and N positions (0 V) - P range signal and N range signal (CAN): OFF 	I
B2605: TRANSMISSION RANGE SWITCH*	Inhibit electronic steering column lock	500 ms after any of the following BCM recognition conditions is fulfilled <ul style="list-style-type: none"> • Ignition switch is in the ON position - Power position: IGN - Selector lever transmission range switch signal: Except P and N positions (0 V) - Transmission range switch signal (CAN): OFF • Status 2 <ul style="list-style-type: none"> - Ignition switch is in the ON position - Selector lever transmission range switch signal: P or N position (battery voltage) - Transmission range switch signal (CAN): ON 	J
B2606: S/L RELAY*	Inhibit engine cranking	500 ms after the following CAN signal communication status has become consistent <ul style="list-style-type: none"> • Electronic steering column lock relay signal (Request signal) • Electronic steering column lock relay signal (Condition signal) 	K

EXL

BCM (BODY CONTROL MODULE)

< ECU DIAGNOSIS >

[XENON TYPE]

Display contents of CONSULT	Fail-safe	Cancellation
B2607: S/L RELAY*	Inhibit engine cranking	500 ms after the following CAN signal communication status has become consistent <ul style="list-style-type: none"> Electronic steering column lock relay signal (Request signal) Electronic steering column lock relay signal (Condition signal)
B2608: STARTER RELAY	Inhibit engine cranking	500 ms after the following signal communication status becomes consistent <ul style="list-style-type: none"> Starter motor relay control signal Starter relay status signal (CAN)
B2609: S/L STATUS*	<ul style="list-style-type: none"> Inhibit engine cranking Inhibit electronic steering column lock 	When the following electronic steering column lock conditions agree <ul style="list-style-type: none"> BCM electronic steering column lock control status Electronic steering column lock condition No. 1 signal status Electronic steering column lock condition No. 2 signal status
B260A: IGNITION RELAY	Inhibit engine cranking	500 ms after the following conditions are fulfilled <ul style="list-style-type: none"> IGN relay (IPDM E/R) control signal: OFF (Battery voltage) Ignition ON signal (CAN to IPDM E/R): OFF (Request signal) Ignition ON signal (CAN from IPDM E/R): OFF (Condition signal)
B260F: ENG STATE SIG LOST	Maintains the power supply position attained at the time of DTC detection	When any of the following conditions is fulfilled <ul style="list-style-type: none"> Power position changes to ACC Receives engine status signal (CAN)
B2612: S/L STATUS*	<ul style="list-style-type: none"> Inhibit engine cranking Inhibit electronic steering column lock 	When any of the following conditions is fulfilled <ul style="list-style-type: none"> Electronic steering column lock unit status signal (CAN) is received normally The BCM electronic steering column lock control status matches the electronic steering column lock status recognized by the electronic steering column lock unit status signal (CAN from IPDM E/R)
B2617: STARTER RELAY CIRC	Inhibit engine cranking	1 second after the starter motor relay control inside BCM becomes normal
B2618: BCM	Inhibit engine cranking	1 second after the ignition relay (IPDM E/R) control inside BCM becomes normal
B2619: BCM*	Inhibit engine cranking	1 second after the electronic steering column lock unit power supply output control inside BCM becomes normal
B26E1: ENG STATE NO RECIV	Inhibit engine cranking	When any of the following conditions are fulfilled <ul style="list-style-type: none"> Power position changes to ACC Receives engine status signal (CAN)

* : With electronic steering column lock

DTC Inspection Priority Chart

INFOID:000000005530151

If some DTCs are displayed at the same time, perform inspections one by one based on the following priority chart.

Priority	DTC
1	<ul style="list-style-type: none"> B2562: LO VOLTAGE
2	<ul style="list-style-type: none"> U1000: CAN COMM CIRCUIT U1010: CONTROL UNIT (CAN)
3	<ul style="list-style-type: none"> B2190: NATS ANTENNA AMP B2191: DIFFERENCE OF KEY B2192: ID DISCORD BCM-ECM B2193: CHAIN OF BCM-ECM

BCM (BODY CONTROL MODULE)

[XENON TYPE]

< ECU DIAGNOSIS >

Priority	DTC		
4	<ul style="list-style-type: none"> • B2013: ID DISCORD BCM-S/L* • B2014: CHAIN OF S/L-BCM* • B2553: IGNITION RELAY • B2555: STOP LAMP • B2556: PUSH-BTN IGN SW • B2557: VEHICLE SPEED • B2560: STARTER CONT RELAY • B2601: SHIFT POSITION • B2602: SHIFT POSITION • B2603: SHIFT POSI STATUS • B2604: TRANSMISSION RANGE SWITCH • B2605: TRANSMISSION RANGE SWITCH • B2606: S/L RELAY* • B2607: S/L RELAY* • B2608: STARTER RELAY • B2609: S/L STATUS* • B260A: IGNITION RELAY • B260B: STEERING LOCK UNIT* • B260C: STEERING LOCK UNIT* • B260D: STEERING LOCK UNIT* • B260F: ENG STATE SIG LOST • B2612: S/L STATUS* • B2614: ACC RELAY CIRC • B2615: BLOWER RELAY CIRC • B2616: IGN RELAY CIRC • B2617: STARTER RELAY CIRC • B2618: BCM • B2619: BCM* • B261A: PUSH-BTN IGN SW • B26E1: ENG STATE NO RECIV • C1729: VHCL SPEED SIG ERR • U0415: VEHICLE SPEED SIG 	<p style="text-align: center;">A</p> <p style="text-align: center;">B</p> <p style="text-align: center;">C</p> <p style="text-align: center;">D</p> <p style="text-align: center;">E</p> <p style="text-align: center;">F</p> <p style="text-align: center;">G</p> <p style="text-align: center;">H</p> <p style="text-align: center;">I</p> <p style="text-align: center;">J</p>	
	<ul style="list-style-type: none"> • C1704: LOW PRESSURE FL • C1705: LOW PRESSURE FR • C1706: LOW PRESSURE RR • C1707: LOW PRESSURE RL • C1708: [NO DATA] FL • C1709: [NO DATA] FR • C1710: [NO DATA] RR • C1711: [NO DATA] RL • C1712: [CHECKSUM ERR] FL • C1713: [CHECKSUM ERR] FR • C1714: [CHECKSUM ERR] RR • C1715: [CHECKSUM ERR] RL • C1716: [PRESSDATA ERR] FL • C1717: [PRESSDATA ERR] FR • C1718: [PRESSDATA ERR] RR • C1719: [PRESSDATA ERR] RL • C1720: [CODE ERR] FL • C1721: [CODE ERR] FR • C1722: [CODE ERR] RR • C1723: [CODE ERR] RL • C1724: [BATT VOLT LOW] FL • C1725: [BATT VOLT LOW] FR • C1726: [BATT VOLT LOW] RR • C1727: [BATT VOLT LOW] RL • C1734: CONTROL UNIT 	<p style="text-align: center;">K</p> <p style="text-align: center;">EXL</p> <p style="text-align: center;">M</p> <p style="text-align: center;">N</p> <p style="text-align: center;">O</p> <p style="text-align: center;">P</p>	
	6	<ul style="list-style-type: none"> • B2622: INSIDE ANTENNA • B2623: INSIDE ANTENNA 	

* : With electronic steering column lock

BCM (BODY CONTROL MODULE)

[XENON TYPE]

< ECU DIAGNOSIS >

DTC Index

INFOID:000000005530152

NOTE:

- Details of time display
- CRNT: Displays when there is a malfunction now or after returning to the normal condition until turning ignition switch OFF → ON again.
- 1 - 39: Displayed if any previous malfunction is present when current condition is normal. It increases 1 → 2 → 3...38 → 39 after returning to the normal condition whenever ignition switch OFF → ON. The counter remains at 39 even if the number of cycles exceeds it. It is counted from 1 again when turning ignition switch OFF → ON after returning to the normal condition if the malfunction is detected again.

CONSULT display	Fail-safe	Intelligent Key warning lamp ON	Tire pressure monitor warning lamp ON	Reference page
No DTC is detected. further testing may be required.	—	—	—	—
U1000: CAN COMM CIRCUIT	—	—	—	BCS-36
U1010: CONTROL UNIT (CAN)	—	—	—	BCS-37
U0415: VEHICLE SPEED SIG	—	—	—	BCS-38
B2013: ID DISCORD BCM-S/L*	×	—	—	SEC-39
B2014: CHAIN OF S/L-BCM*	×	—	—	SEC-40
B2190: NATS ANTENNA AMP	×	—	—	SEC-43
B2191: DIFFERENCE OF KEY	×	—	—	SEC-46
B2192: ID DISCORD BCM-ECM	×	—	—	SEC-47
B2193: CHAIN OF BCM-ECM	×	—	—	SEC-48
B2553: IGNITION RELAY	—	—	—	PCS-55
B2555: STOP LAMP	—	—	—	SEC-49
B2556: PUSH-BTN IGN SW	—	×	—	SEC-52
B2557: VEHICLE SPEED	×	×	—	SEC-54
B2560: STARTER CONT RELAY	×	×	—	SEC-55
B2562: LOW VOLTAGE	—	—	—	BCS-39
B2601: SHIFT POSITION	×	×	—	SEC-56
B2602: SHIFT POSITION	×	×	—	SEC-59
B2603: SHIFT POSI STATUS	×	×	—	SEC-62
B2604: TRANSMISSION RANGE SWITCH	×	×	—	SEC-65
B2605: TRANSMISSION RANGE SWITCH	×	×	—	SEC-67
B2606: S/L RELAY*	×	×	—	SEC-69
B2607: S/L RELAY*	×	×	—	SEC-70
B2608: STARTER RELAY	×	×	—	SEC-72
B2609: S/L STATUS*	×	×	—	SEC-74
B260A: IGNITION RELAY	×	×	—	PCS-57
B260B: STEERING LOCK UNIT*	—	×	—	SEC-78
B260C: STEERING LOCK UNIT*	—	×	—	SEC-79
B260D: STEERING LOCK UNIT*	—	×	—	SEC-80
B260F: ENG STATE SIG LOST	×	×	—	SEC-81
B2612: S/L STATUS*	×	×	—	SEC-83
B2614: ACC RELAY CIRC	—	×	—	PCS-59

BCM (BODY CONTROL MODULE)

< ECU DIAGNOSIS >

[XENON TYPE]

CONSULT display	Fail-safe	Intelligent Key warning lamp ON	Tire pressure monitor warning lamp ON	Reference page	
B2615: BLOWER RELAY CIRC	—	×	—	PCS-62	A
B2616: IGN RELAY CIRC	—	×	—	PCS-65	B
B2617: STARTER RELAY CIRC	×	×	—	PCS-65	
B2618: BCM	×	×	—	PCS-68	C
B2619: BCM*	×	×	—	SEC-89	
B261A: PUSH-BTN IGN SW	—	×	—	SEC-90	
B2622: INSIDE ANTENNA	—	—	—	DLK-60	D
B2623: INSIDE ANTENNA	—	—	—	DLK-63	
B26E1: ENG STATE NO RES	×	×	—	SEC-82	E
C1704: LOW PRESSURE FL	—	—	×	WT-48	
C1705: LOW PRESSURE FR	—	—	×	WT-48	
C1706: LOW PRESSURE RR	—	—	×	WT-48	F
C1707: LOW PRESSURE RL	—	—	×	WT-48	
C1708: [NO DATA] FL	—	—	×	WT-14	G
C1709: [NO DATA] FR	—	—	×	WT-14	
C1710: [NO DATA] RR	—	—	×	WT-14	
C1711: [NO DATA] RL	—	—	×	WT-14	H
C1712: [CHECKSUM ERR] FL	—	—	×	WT-16	
C1713: [CHECKSUM ERR] FR	—	—	×	WT-16	I
C1714: [CHECKSUM ERR] RR	—	—	×	WT-16	
C1715: [CHECKSUM ERR] RL	—	—	×	WT-16	
C1716: [PRESSDATA ERR] FL	—	—	×	WT-18	J
C1717: [PRESSDATA ERR] FR	—	—	×	WT-18	
C1718: [PRESSDATA ERR] RR	—	—	×	WT-18	K
C1719: [PRESSDATA ERR] RL	—	—	×	WT-18	
C1720: [CODE ERR] FL	—	—	×	WT-16	
C1721: [CODE ERR] FR	—	—	×	WT-16	EXL
C1722: [CODE ERR] RR	—	—	×	WT-16	
C1723: [CODE ERR] RL	—	—	×	WT-16	
C1724: [BATT VOLT LOW] FL	—	—	×	WT-16	M
C1725: [BATT VOLT LOW] FR	—	—	×	WT-16	
C1726: [BATT VOLT LOW] RR	—	—	×	WT-16	N
C1727: [BATT VOLT LOW] RL	—	—	×	WT-16	
C1729: VHCL SPEED SIG ERR	—	—	×	WT-20	O
C1734: CONTROL UNIT	—	—	×	WT-21	

* : With electronic steering column lock

IPDM E/R (INTELLIGENT POWER DISTRIBUTION MODULE ENGINE ROOM)

< ECU DIAGNOSIS >

[XENON TYPE]

IPDM E/R (INTELLIGENT POWER DISTRIBUTION MODULE ENGINE ROOM)

Reference Value

INFOID:000000005530266

VALUES ON THE DIAGNOSIS TOOL

Monitor Item	Condition		Value/Status
MOTOR FAN REQ	Engine idle speed	Changes depending on engine coolant temperature, air conditioner operation status, vehicle speed, etc.	1,2,3,4
AC COMP REQ	Engine running	A/C switch OFF	Off
		A/C switch ON (Compressor is operating)	On
TAIL&CLR REQ	Lighting switch OFF		Off
	Lighting switch 1ST, 2ND, HI or AUTO (Light is illuminated)		On
HL LO REQ	Lighting switch OFF		Off
	Lighting switch 2ND HI or AUTO (Light is illuminated)		On
HL HI REQ	Lighting switch OFF		Off
	Lighting switch HI		On
FR FOG REQ	Lighting switch 2ND or AUTO (Light is illuminated)	Front fog lamp switch OFF	Off
		<ul style="list-style-type: none"> • Front fog lamp switch ON • Daytime running light activated (Only for Canada models) 	On
FR WIP REQ	Ignition switch ON	Front wiper switch OFF	STOP
		Front wiper switch INT	1LOW
		Front wiper switch LO	Low
		Front wiper switch HI	Hi
WIP AUTO STOP	Ignition switch ON	Front wiper stop position	STOP P
		Any position other than front wiper stop position	ACT P
WIP PROT	Ignition switch ON	Front wiper operates normally	Off
		Front wiper stops at fail-safe operation	BLOCK
IGN RLY1 -REQ	Ignition switch OFF or ACC		Off
	Ignition switch ON		On
IGN RLY	Ignition switch OFF or ACC		Off
	Ignition switch ON		On
PUSH SW	Release the push-button ignition switch		Off
	Press the push-button ignition switch		On
INTER/NP SW	Ignition switch ON	CVT selector lever in any position other than P or N	Off
	Ignition switch ON	CVT selector lever in P or N position	On
ST RLY CONT	Ignition switch ON		Off
	At engine cranking		On
IHBT RLY -REQ	Ignition switch ON		Off
	At engine cranking		On

IPDM E/R (INTELLIGENT POWER DISTRIBUTION MODULE ENGINE ROOM)

< ECU DIAGNOSIS >

[XENON TYPE]

Monitor Item	Condition	Value/Status
ST/INH RLY	Ignition switch ON	Off
	At engine cranking	ST →INH
	The status of starter relay or starter control relay cannot be recognized by the battery voltage malfunction, etc. when the starter relay is ON and the starter control relay is OFF	UNKWN
DETENT SW	Ignition switch ON <ul style="list-style-type: none"> Press the selector button with CVT selector lever in P position CVT selector lever in any position other than P 	Off
	Release the CVT selector button with CVT selector lever in P position	On
S/L RLY -REQ ¹	None of the conditions below are present	Off
	<ul style="list-style-type: none"> Open the driver door after the ignition switch is turned OFF (for a few seconds) Press the push-button ignition switch when the steering lock is activated 	On
S/L STATE ¹	Steering lock is activated	LOCK
	Steering lock is deactivated	UNLK
	[DTC B210A] is detected	UNKWN
DTRL -REQ	DTRL ON	On
	DTRL OFF	Off
OIL P SW	Ignition switch OFF, ACC or engine running	Open
	Ignition switch ON	Close
THFT HRN REQ	Not operated	Off
	<ul style="list-style-type: none"> Panic alarm is activated Horn is activated with VEHICLE SECURITY (THEFT WARNING) SYSTEM 	On
HORN CHIRP	Not operated	Off
	Door locking with Intelligent Key (horn chirp mode)	On

1: Early production

A
B
C
D
E
F
G
H
I
J
K

EXL

M
N
O
P

IPDM E/R (INTELLIGENT POWER DISTRIBUTION MODULE ENGINE ROOM)

< ECU DIAGNOSIS >

[XENON TYPE]

TERMINAL LAYOUT

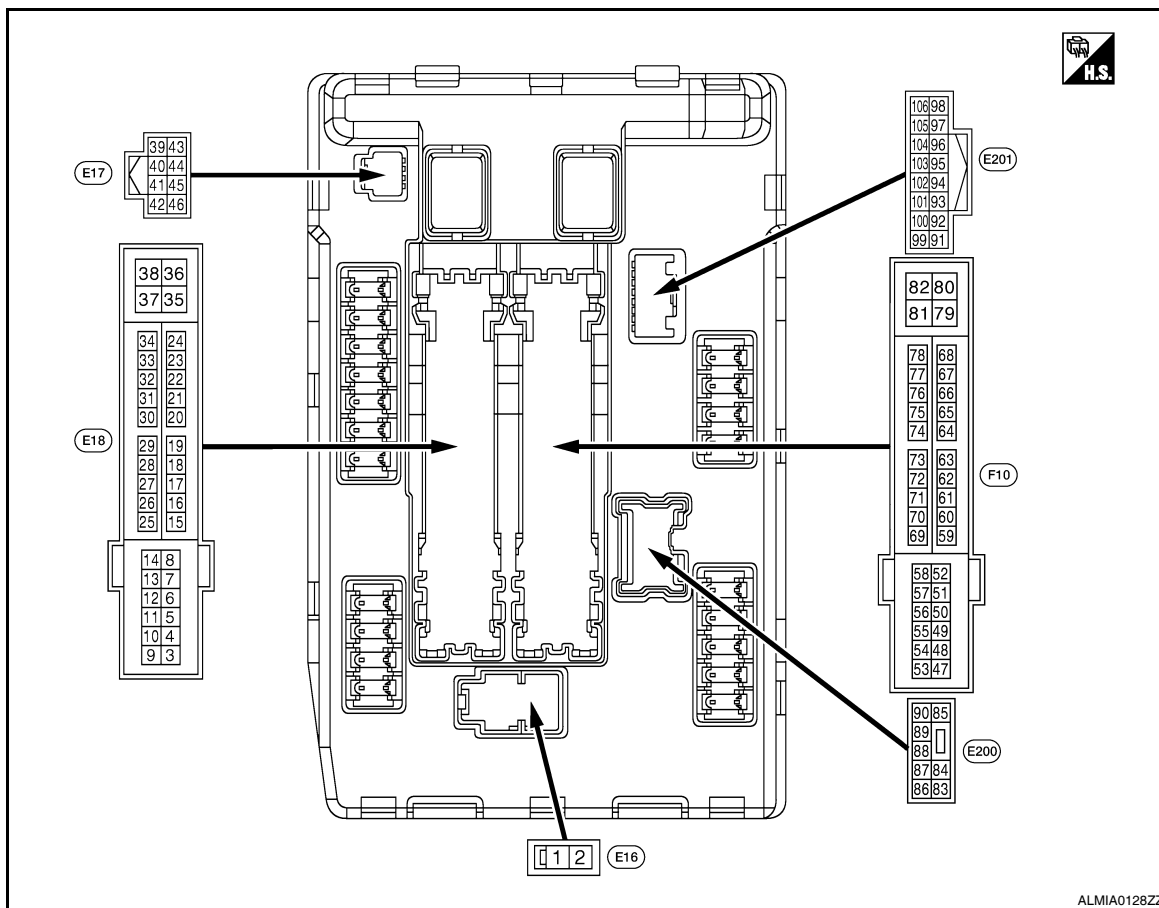

ALMIA0128ZZ

PHYSICAL VALUES

Terminal No. (Wire color)		Description		Condition		Value (Approx.)
+	-	Signal name	Input/ Output			
1 (R)	Ground	Battery power supply	Input	Ignition switch OFF		Battery voltage
2 (L)	Ground	Battery power supply	Input	Ignition switch OFF		Battery voltage
4 (LG)	Ground	Front wiper LO	Output	Ignition switch OFF	Front wiper switch OFF	0 V
				Ignition switch ON	Front wiper switch LO	Battery voltage
5 (Y)	Ground	Front wiper HI	Output	Ignition switch OFF	Front wiper switch OFF	0 V
				Ignition switch ON	Front wiper switch HI	Battery voltage
6 (L)	Ground	Daytime light relay power supply (Canada models only)	Output	Ignition switch OFF		Battery voltage
7 (GR)	Ground	Tail, license plate lamps & interior lamps	Output	Ignition switch OFF	Lighting switch OFF	0 V
				Ignition switch ON	Lighting switch 1ST	Battery voltage
10 (BR)	Ground	ECM relay power supply	Output	Ignition switch OFF (For a few seconds after turning ignition switch OFF)		0 V
				<ul style="list-style-type: none"> Ignition switch ON Ignition switch OFF (More than a few seconds after turning ignition switch OFF) 		Battery voltage

IPDM E/R (INTELLIGENT POWER DISTRIBUTION MODULE ENGINE ROOM)

< ECU DIAGNOSIS >

[XENON TYPE]

Terminal No. (Wire color)		Description		Condition		Value (Approx.)	
+	-	Signal name	Input/ Output				
11 ¹ (O)	Ground	Electronic steering column lock power supply	Output	Ignition switch OFF	A few seconds after opening the driver door	Battery voltage	A
				Ignition switch LOCK	Press the push-button ignition switch	Battery voltage	B
				Ignition switch ACC or ON		0 V	C
12 (B)	Ground	Ground	—	Ignition switch ON		0 V	D
13 (SB)	Ground	Fuel pump power supply	Output	Approximately 1 second or more after turning the ignition switch ON		0 V	E
				<ul style="list-style-type: none"> • Approximately 1 second after turning the ignition switch ON • Engine running 		Battery voltage	F
15 (W)	Ground	Ignition relay-1 power supply	Output	Ignition switch OFF		0 V	G
				Ignition switch ON		Battery voltage	H
16 (R)	Ground	Front wiper auto stop	Input	Ignition switch ON	Front wiper stop position	0 V	I
					Any position other than front wiper stop position		Battery voltage
19 (Y)	Ground	Ignition relay-1 power supply	Output	Ignition switch OFF		0 V	K
				Ignition switch ON		Battery voltage	EXL
20 (L)	Ground	Ambient sensor ground	—	Ignition switch ON		0V	M
21 (LG)	Ground	Ambient sensor	—	Ignition switch ON		5V	N
22 (SB)	Ground	Refrigerant pressure sensor ground	—	Ignition switch ON		0V	O
23 (GR)	Ground	Refrigerant pressure sensor	—	<ul style="list-style-type: none"> • Ignition switch ON (READY) • Both A/C switch and blower motor switch ON (electric compressor operates) 		1.0 - 4.0V	P
24 (G)	Ground	Refrigerant pressure sensor power supply	—	Ignition switch ON		5V	EXL
25 (GR)	Ground	Ignition relay-1 power supply	Output	Ignition switch OFF		0 V	M
				Ignition switch ON		Battery voltage	N
27 (W)	Ground	Ignition relay monitor	Input	Ignition switch OFF or ACC		Battery voltage	O
				Ignition switch ON		0 V	P
28 (SB)	Ground	Push-button ignition switch	Input	Press the push-button ignition switch		0 V	O
				Release the push-button ignition switch		Battery voltage	P
30 (BR)	Ground	Starter relay control	Input	CVT selector lever in any position other than P or N (ignition switch ON)		0 V	O
				CVT selector lever P or N (ignition switch ON)		Battery voltage	P
32 ¹ (P)	Ground	Electronic steering column lock unit condition-1	Input	Electronic steering column lock is activated		0 V	P
				Electronic steering column lock is deactivated		Battery voltage	P

IPDM E/R (INTELLIGENT POWER DISTRIBUTION MODULE ENGINE ROOM)

< ECU DIAGNOSIS >

[XENON TYPE]

Terminal No. (Wire color)		Description		Condition		Value (Approx.)
+	-	Signal name	Input/ Output			
33 ¹ (G)	Ground	Electronic steering column lock condition-2	Input	Electronic steering column lock is activated	Battery voltage	
				Electronic steering column lock is deactivated	0 V	
34 (O)	Ground	Cooling fan relay-3 control	Input	Ignition switch OFF or ACC	0 V	
				Ignition switch ON	0.7 V	
35 (P)	Ground	Cooling fan motor control	Output	Ignition switch OFF or ACC	0 V	
				Ignition switch ON	0.7 V	
36 (G)	Ground	Battery power supply	Input	Ignition switch OFF	Battery voltage	
38 (GR)	Ground	Cooling fan motor control	Output	Ignition switch OFF or ACC	0 V	
				Ignition switch ON	0.7 V	
39 (P)	—	CAN - L	Input/ Output	—	—	
40 (L)	—	CAN - H	Input/ Output	—	—	
41 (B)	Ground	Ground	—	Ignition switch ON	0 V	
42 (SB)	Ground	Cooling fan relay-2 control	Input	Ignition switch OFF or ACC	0 V	
				Ignition switch ON	0.7 V	
43 (Y)	Ground	CVT shift selector (Detention switch)	Input	Press the CVT selector button (CVT selector lever P)	Battery voltage	
				Ignition switch ON	<ul style="list-style-type: none"> • CVT selector lever in any position other than P • Release the CVT selector button (CVT selector lever P) 	0 V
44 (W)	Ground	Horn relay control	Input	The horn is deactivated	Battery voltage	
				The horn is activated	0 V	
45 (GR)	Ground	Anti theft horn relay control	Input	The horn is deactivated	Battery voltage	
				The horn is activated	0 V	
46 (BR)	Ground	Starter relay control	Input	CVT selector lever in any position other than P or N (ignition switch ON)	0 V	
				CVT selector lever P or N (ignition switch ON)	Battery voltage	
48 (W)	Ground	A/C relay power supply	Output	Engine running	A/C switch OFF	0 V
				A/C switch ON (A/C compressor is operating)	Battery voltage	
49 (R/G)	Ground	ECM relay power supply	Output	Ignition switch OFF (For a few seconds after turning ignition switch OFF)	0 V	
				<ul style="list-style-type: none"> • Ignition switch ON • Ignition switch OFF (More than a few seconds after turning ignition switch OFF) 	Battery voltage	
51 (LG)	Ground	Ignition relay power supply	Output	Ignition switch OFF	0 V	
				Ignition switch ON	Battery voltage	

IPDM E/R (INTELLIGENT POWER DISTRIBUTION MODULE ENGINE ROOM)

< ECU DIAGNOSIS >

[XENON TYPE]

Terminal No. (Wire color)		Description		Condition		Value (Approx.)	
52 (Y/G)	Ground	Ignition relay power supply	Output	Ignition switch OFF		0 V	A
				Ignition switch ON		Battery voltage	B
53 (R/W)	Ground	ECM relay power supply	Output	Ignition switch OFF (For a few seconds after turning ignition switch OFF)		0 V	C
				<ul style="list-style-type: none"> • Ignition switch ON • Ignition switch OFF (More than a few seconds after turning ignition switch OFF) 		Battery voltage	D
54 (G/W)	Ground	Throttle control motor relay power supply	Output	Ignition switch OFF (For a few seconds after turning ignition switch OFF)		0 V	E
				<ul style="list-style-type: none"> • Ignition switch ON • Ignition switch OFF (More than a few seconds after turning ignition switch OFF) 		Battery voltage	F
55 (W/L)	Ground	ECM power supply	Output	Ignition switch OFF		Battery voltage	G
56 (R/Y)	Ground	Ignition relay power supply	Output	Ignition switch OFF		0 V	H
				Ignition switch ON		Battery voltage	
57 (O)	Ground	Ignition relay power supply	Output	Ignition switch OFF		0 V	I
				Ignition switch ON		Battery voltage	
58 (Y)	Ground	Ignition relay power supply	Output	Ignition switch OFF		0 V	J
				Ignition switch ON		Battery voltage	
69 (W/B)	Ground	ECM relay control	Output	Ignition switch OFF (For a few seconds after turning ignition switch OFF)		Battery voltage	K
				<ul style="list-style-type: none"> • Ignition switch ON • Ignition switch OFF (More than a few seconds after turning ignition switch OFF) 		0 - 1.5 V	
70 (O)	Ground	Throttle control motor relay control	Output	Ignition switch ON → OFF		0 - 1.0 V ↓ Battery voltage ↓ 0 V	M
				Ignition switch ON		0 - 1.0 V	
72 (R/B)	Ground	Transmission range switch signal	Input	Ignition switch ON	CVT selector lever in P or N position	Battery voltage	N
					CVT selector lever in any position other than P or N position	0 V	
75 (LG)	Ground	Oil pressure switch	Input	Ignition switch ON	Engine stopped	0 V	O
					Engine running	Battery voltage	

EXL

IPDM E/R (INTELLIGENT POWER DISTRIBUTION MODULE ENGINE ROOM)

< ECU DIAGNOSIS >

[XENON TYPE]

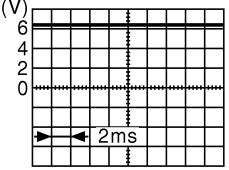
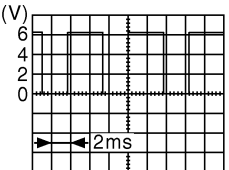
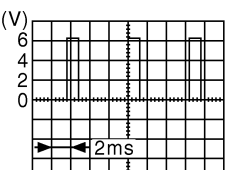
Terminal No. (Wire color)		Description		Condition		Value (Approx.)
+	-	Signal name	Input/ Output			
76 (SB)	Ground	Power generation command signal	Output	Ignition switch ON		 6.3 V
				40% is set on "Active test", "ALTERNATOR DUTY" of "ENGINE"		 3.8 V
				80% is set on "Active test", "ALTERNATOR DUTY" of "ENGINE"		 1.4 V
77 (GR)	Ground	Fuel pump relay control	Output	<ul style="list-style-type: none"> • Approximately 1 second after turning the ignition switch ON • Engine running 		0 - 1.0 V
				Approximately 1 second or more after turning the ignition switch ON		Battery voltage
80 (B/W)	Ground	Starter motor	Output	At engine cranking		Battery voltage
83 (R/Y)	Ground	Headlamp LO (RH)	Output	Ignition switch ON	Lighting switch OFF	0 V
					Lighting switch 2ND	Battery voltage
84 (L)	Ground	Headlamp LO (LH)	Output	Ignition switch ON	Lighting switch OFF	0 V
					Lighting switch 2ND	Battery voltage
86 (W/R)	Ground	Front fog lamp (RH)	Output	Lighting switch 2ND	<ul style="list-style-type: none"> • Front fog lamp switch ON • Daytime running light activated (Only for Canada models) 	Battery voltage
					Front fog lamp switch OFF	0 V
87 (L/Y)	Ground	Front fog lamp (LH)	Output	Lighting switch 2ND	<ul style="list-style-type: none"> • Front fog lamp switch ON • Daytime running light activated (Only for Canada models) 	Battery voltage
					Front fog lamp switch OFF	0 V
88 (R/W)	Ground	Washer pump power supply	Output	Ignition switch ON		Battery voltage

IPDM E/R (INTELLIGENT POWER DISTRIBUTION MODULE ENGINE ROOM)

< ECU DIAGNOSIS >

[XENON TYPE]

Terminal No. (Wire color)		Description		Condition		Value (Approx.)
+	-	Signal name	Input/ Output			
89 (L/W)	Ground	Headlamp HI (RH)	Output	Ignition switch ON	• Lighting switch HI • Lighting switch PASS	Battery voltage
					Lighting switch OFF	0 V
90 (G)	Ground	Headlamp HI (LH)	Output	Ignition switch ON	• Lighting switch HI • Lighting switch PASS	Battery voltage
					Lighting switch OFF	0 V
91 (LG/ R)	Ground	Parking lamp (RH)	Output	Ignition switch ON	Lighting switch 1ST	Battery voltage
					Lighting switch OFF	0 V
92 (LG/ B)	Ground	Parking lamp (LH)	Output	Ignition switch ON	Lighting switch 1ST	Battery voltage
					Lighting switch OFF	0 V
99 (BR/ W)	Ground	Ambient sensor ground	—	Ignition switch ON		0V
100 (SB)	Ground	Ambient sensor	—	Ignition switch ON		5V
101 (W)	Ground	Refrigerant pressure sensor ground	—	Ignition switch ON		0V
102 (R)	Ground	Refrigerant pressure sensor	—	• Ignition switch ON (READY) • Both A/C switch and blower motor switch ON (electric compressor operates)		1.0 - 4.0V
103 (P)	Ground	Refrigerant pressure sensor power supply	—	Ignition switch ON		5V
105 (V)	Ground	Daytime light relay control (Only for Canada models)	Output	Ignition switch ON	Daytime light system active	Battery voltage
				Ignition switch ON	Daytime light system inactive	0 V

1: Early production

A
B
C
D
E
F
G
H
I
J
K

EXL

M
N
O
P

IPDM E/R (INTELLIGENT POWER DISTRIBUTION MODULE ENGINE ROOM)

< ECU DIAGNOSIS >

[XENON TYPE]

Wiring Diagram

INFOID:000000005530267

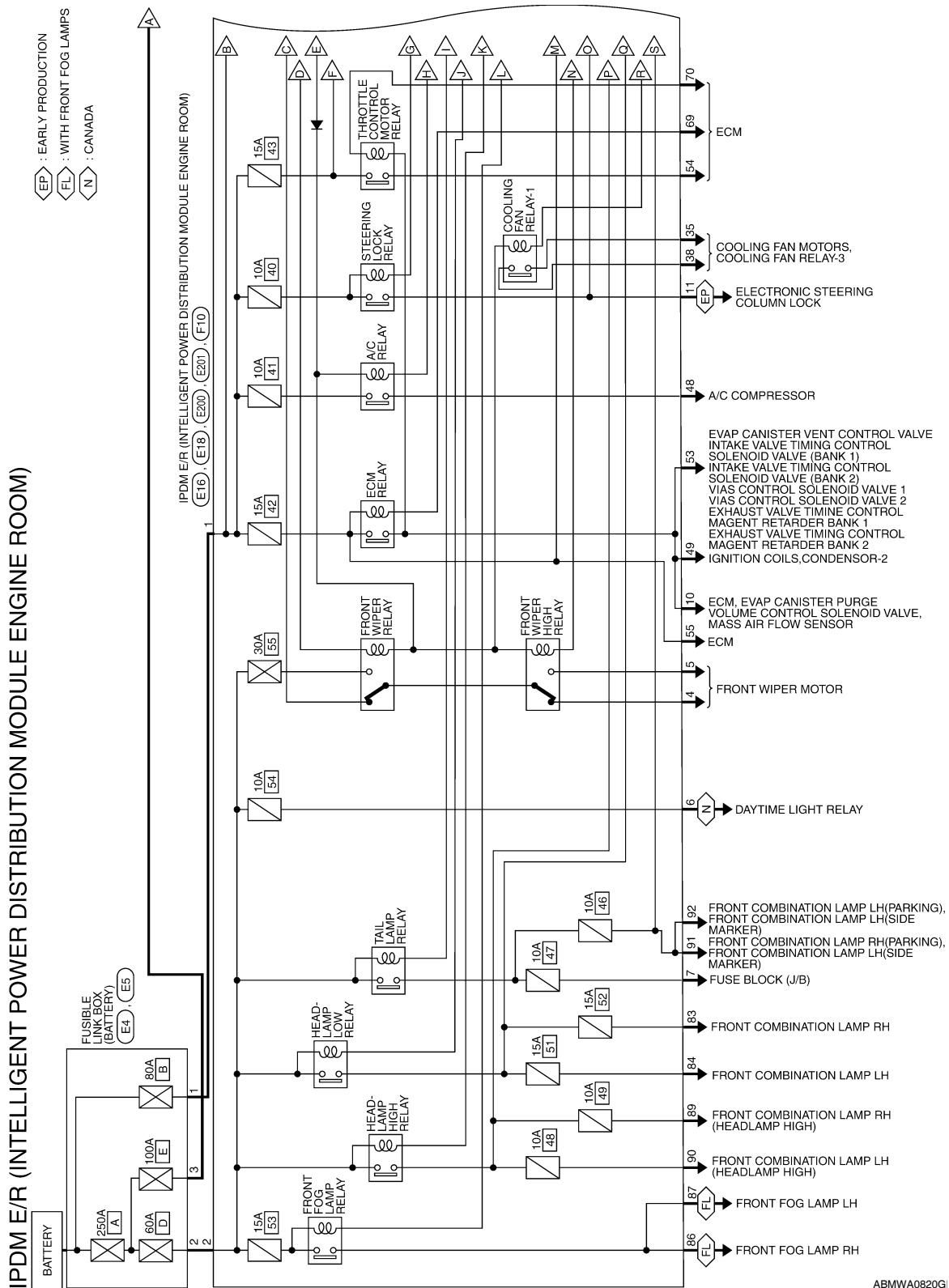

ABMWA0820G

IPDM E/R (INTELLIGENT POWER DISTRIBUTION MODULE ENGINE ROOM)

< ECU DIAGNOSIS >

[XENON TYPE]

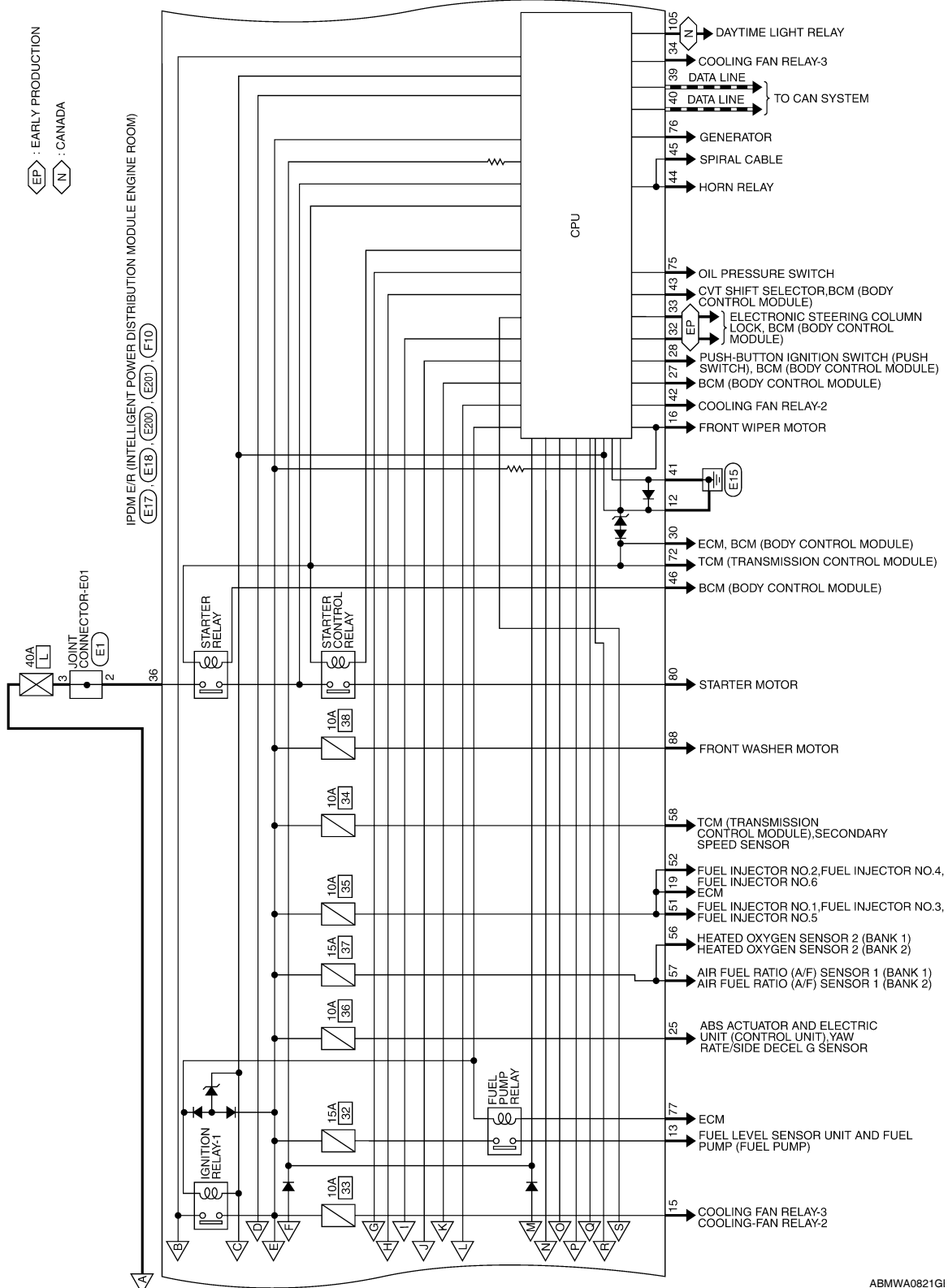

A
B
C
D
E
F
G
H
I
J
K
L
M
N
O
P

EXL

ABMWA0821GI

IPDM E/R (INTELLIGENT POWER DISTRIBUTION MODULE ENGINE ROOM)

< ECU DIAGNOSIS >

[XENON TYPE]

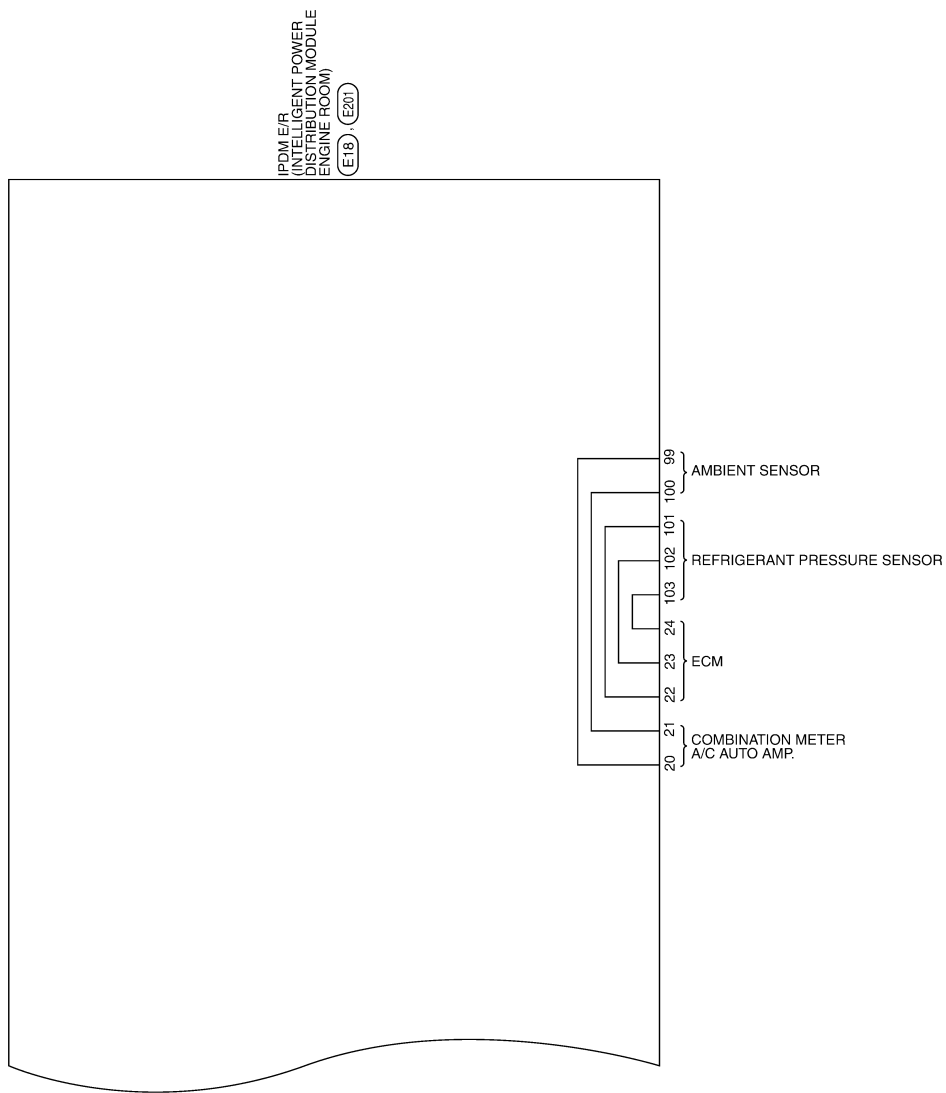

ABMWA0085GI

IPDM E/R (INTELLIGENT POWER DISTRIBUTION MODULE ENGINE ROOM)

< ECU DIAGNOSIS >

[XENON TYPE]

IPDM E/R (INTELLIGENT POWER DISTRIBUTION MODULE ENGINE ROOM) CONNECTORS

Connector No.	E1
Connector Name	JOINT CONNECTOR-E01
Connector Color	WHITE



Terminal No.	Color of Wire	Signal Name
2	G	-
3	G	-

Connector No.	E4
Connector Name	FUSIBLE LINK BOX (BATTERY)
Connector Color	BROWN



Terminal No.	Color of Wire	Signal Name
1	B/W	-
2	L	-

Connector No.	E5
Connector Name	FUSIBLE LINK BOX (BATTERY)
Connector Color	GRAY



Terminal No.	Color of Wire	Signal Name
3	R	-

Connector No.	E16
Connector Name	IPDM E/R (INTELLIGENT POWER DISTRIBUTION MODULE ENGINE ROOM)
Connector Color	BLACK



Terminal No.	Color of Wire	Signal Name
1	R	F/L MAIN
2	L	F/L USM

Connector No.	E17
Connector Name	IPDM E/R (INTELLIGENT POWER DISTRIBUTION MODULE ENGINE ROOM)
Connector Color	WHITE

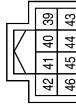

Terminal No.	Color of Wire	Signal Name
39	P	CAN-L
40	L	CAN-H
41	B	GND (SIGNAL)
42	SB	MOTOR FAN RLY MID
43	Y	DETENT SW
44	W	HORN RLY
45	GR	HORN SW
46	BR	START CONT

ABMIA0852GB

A
B
C
D
E
F
G
H
I
J
K
L
M
N
O
P

EXL

IPDM E/R (INTELLIGENT POWER DISTRIBUTION MODULE ENGINE ROOM)

< ECU DIAGNOSIS >

[XENON TYPE]

Connector No.	E18
Connector Name	IPDM E/R (INTELLIGENT POWER DISTRIBUTION MODULE ENGINE ROOM)
Connector Color	WHITE

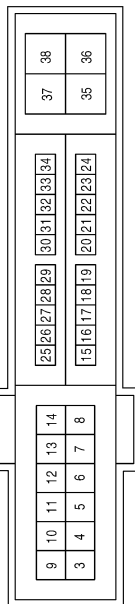

Terminal No.	Color of Wire	Signal Name
3	-	-
4	LG	FR WIPER LO
5	Y	FR WIPER HI
6	L	DTRL/DEICER

Connector No.	E200
Connector Name	IPDM E/R (INTELLIGENT POWER DISTRIBUTION MODULE ENGINE ROOM)
Connector Color	WHITE

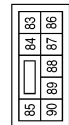

Terminal No.	Color of Wire	Signal Name
83	R/Y	HEADLAMP LO RH
84	L	HEADLAMP LO LH
85	-	-
86	W/R	FR FOG LAMP RH
87	L/Y	FR FOG LAMP LH
88	R/W	WASHER MTR
89	L/W	HEADLAMP HI RH
90	G	HEADLAMP HI LH

Terminal No.	Color of Wire	Signal Name
7	GR	TAIL/ILLUMI
8	-	-
9	-	-
10	BR	ECM VB
11	O	ESCL (EARLY PRODUCTION)
12	B	GND (POWER)
13	SB	FUEL PUMP
14	-	-
15	W	START IG E/R
16	R	WIPER AUTOSTOP
17	-	-
18	-	-
19	Y	BCM IGNSW
20	L	AMB SENS GND-E/R
21	LG	AMB SENS SIG-E/R
22	SB	PD SENS GND-E/R
23	GR	PD SENS SIG-E/R

Terminal No.	Color of Wire	Signal Name
24	G	PD SENS PWR-E/R
25	GR	ABS ECU
26	-	-
27	W	IGN SIGNAL
28	SB	PUSH START SW
29	-	-
30	BR	CLUTCH I/L SW
31	-	-
32	P	SL CONDITION 1 (EARLY PRODUCTION)
33	G	SL CONDITION 2 (EARLY PRODUCTION)
34	O	MOTOR FAN RLY HI
35	P	MOTOR FAN LO
36	G	F/L IGNSW
37	-	-
38	GR	F/L MOTOR FAN

Connector No.	E201
Connector Name	IPDM E/R (INTELLIGENT POWER DISTRIBUTION MODULE ENGINE ROOM)
Connector Color	WHITE



Terminal No.	Color of Wire	Signal Name
91	LG/R	CLEARANCE RH
92	LG/B	CLEARANCE LH
93	-	-
94	-	-
95	-	-
96	-	-
97	-	-

Terminal No.	Color of Wire	Signal Name
98	-	-
99	BR/W	AMB SENS GND-FEM
100	SB	AMB SENS SIG-FEM
101	W	PD SENS GND FEM
102	R	PD SENS SIG FEM
103	P	PD SENS PWR FEM
104	-	-
105	V	DTRL RLY
106	-	-

IPDM E/R (INTELLIGENT POWER DISTRIBUTION MODULE ENGINE ROOM)

< ECU DIAGNOSIS >

[XENON TYPE]

Terminal No.	Color of Wire	Signal Name
70	O	MOTRLY
71	-	-
72	R/B	NP SW
73	-	-
74	-	-
75	LG	OIL PRESSURE SW
76	SB	ALT C
77	GR	FPR
78	-	-
79	-	-
80	B/W	STARTER MOTOR

Terminal No.	Color of Wire	Signal Name
47	-	-
48	W	A/C COMP
49	R/G	ING COIL
50	-	-
51	LG	INJECTOR #1
52	Y/G	INJECTOR #2
53	R/W	ENG SOL
54	G/W	ETC
55	W/L	ECM BAT
56	R/Y	O2 SENS #1
57	O	O2 SENS #2
58	Y	AT ECU
59	-	-
60	-	-
61	-	-
62	-	-
63	-	-
64	-	-
65	-	-
66	-	-
67	-	-
68	-	-
69	W/B	SSOFF

Connector No.	F10
Connector Name	IPDM E/R (INTELLIGENT POWER DISTRIBUTION MODULE ENGINE ROOM)
Connector Color	WHITE

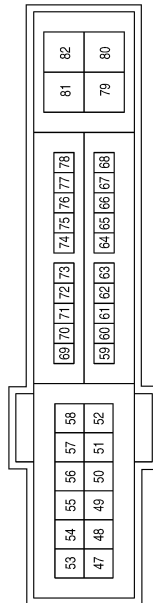

A
B
C
D
E
F
G
H
I
J
K
L
M
N
O
P

EXL

ABMIA1348GB

INFOID:000000005530268

Fail Safe

CAN COMMUNICATION CONTROL

When CAN communication with ECM and BCM is impossible, IPDM E/R performs fail-safe control. After CAN communication recovers normally, it also returns to normal control.

If No CAN Communication Is Available With ECM

IPDM E/R (INTELLIGENT POWER DISTRIBUTION MODULE ENGINE ROOM)

< ECU DIAGNOSIS >

[XENON TYPE]

Control part	Fail-safe in operation
Cooling fan	<ul style="list-style-type: none"> • Signals cooling fans ON when the ignition switch is turned ON • Signals cooling fans OFF when the ignition switch is turned OFF
A/C compressor	A/C relay OFF
Generator	Outputs the power generation command signal (PWM signal) 0%

If No CAN Communication Is Available With BCM

Control part	Fail-safe in operation
Headlamp	<ul style="list-style-type: none"> • Turns ON the headlamp low relay when the ignition switch is turned ON • Turns OFF the headlamp low relay when the ignition switch is turned OFF • Headlamp high relay OFF
<ul style="list-style-type: none"> • Parking lamps • License plate lamps • Illumination • Tail lamps 	<ul style="list-style-type: none"> • Turns ON the tail lamp relay when the ignition switch is turned ON • Turns OFF the tail lamp relay when the ignition switch is turned OFF
Front wiper	<ul style="list-style-type: none"> • The status just before activation of fail-safe control is maintained until the ignition switch is turned OFF while the front wiper is operating at LO or HI speed. • The wiper is operated at LO speed until the ignition switch is turned OFF if the fail-safe control is activated while the front wiper is set in the INT mode and the front wiper motor is operating.
Front fog lamps (if equipped)	Front fog lamp relay OFF
Horn	Horn OFF
Ignition relay	The status just before activation of fail-safe is maintained.
Starter motor	Starter control relay OFF
Electronic steering column lock ¹	Steering lock relay OFF

1: Early production

IGNITION RELAY MALFUNCTION DETECTION FUNCTION

- IPDM E/R monitors the voltage at the contact circuit and excitation coil circuit of the ignition relay inside it.
- IPDM E/R judges the ignition relay error if the voltage differs between the contact circuit and the excitation coil circuit.
- If the ignition relay cannot turn OFF due to contact seizure, it activates the tail lamp relay for 10 minutes to alert the user to the ignition relay malfunction when the ignition switch is turned OFF.

DTC	Ignition switch	Ignition relay	Tail lamp relay
—	ON	ON	—
—	OFF	OFF	—
B2098: IGN RELAY ON	OFF	ON	ON (10 minutes)
B2099: IGN RELAY OFF	ON	OFF	—

NOTE:

The tail lamp turns OFF when the ignition switch is turned ON.

FRONT WIPER CONTROL

IPDM E/R detects front wiper stop position by a front wiper auto stop signal.

When a front wiper auto stop signal is in the conditions listed below, IPDM E/R stops power supply to wiper after repeating a front wiper 10 second activation and 20 second stop five times.

Ignition switch	Front wiper switch	Auto stop signal
ON	OFF	Front wiper stop position signal cannot be input 10 seconds.
	ON	The signal does not change for 10 seconds.

NOTE:

IPDM E/R (INTELLIGENT POWER DISTRIBUTION MODULE ENGINE ROOM)

[XENON TYPE]

< ECU DIAGNOSIS >

This operation status can be confirmed on the IPDM E/R “Data Monitor” that displays “BLOCK” for the item “WIP PROT” while the wiper is stopped.

STARTER MOTOR PROTECTION FUNCTION

IPDM E/R turns OFF the starter control relay to protect the starter motor when the starter control relay remains active for 90 seconds.

DTC Index

INFOID:000000005530269

CONSULT-III display	Fail-safe	TIME ^{NOTE}		Refer to
No DTC is detected. further testing may be required.	—	—	—	—
U1000: CAN COMM CIRCUIT	×	CRNT	1 – 39	PCS-19
B2098: IGN RELAY ON	×	CRNT	1 – 39	PCS-20
B2099: IGN RELAY OFF	—	CRNT	1 – 39	PCS-21
B2108: STRG LCK RELAY ON	—	CRNT	1 – 39	SEC-92
B2109: STRG LCK RELAY OFF	—	CRNT	1 – 39	SEC-93
B210A: STRG LCK STATE SW	—	CRNT	1 – 39	SEC-94
B210B: START CONT RLY ON	—	CRNT	1 – 39	SEC-98
B210C: START CONT RLY OFF	—	CRNT	1 – 39	SEC-99
B210D: STARTER RELAY ON	—	CRNT	1 – 39	SEC-100
B210E: STARTER RELAY OFF	—	CRNT	1 – 39	SEC-101
B210F: INTRLCK/PNP SW ON	—	CRNT	1 – 39	SEC-103
B2110: INTRLCK/PNP SW OFF	—	CRNT	1 – 39	SEC-105

NOTE:

The details of TIME display are as follows.

- CRNT: The malfunctions that are detected now
- 1 - 39: The number is indicated when it is normal at present and a malfunction was detected in the past. It increases like 0 → 1 → 2 ... 38 → 39 after returning to the normal condition whenever IGN OFF → ON. It is fixed to 39 until the self-diagnosis results are erased if it is over 39. It returns to 0 when a malfunction is detected again in the process.

EXL

EXTERIOR LIGHTING SYSTEM SYMPTOMS

< SYMPTOM DIAGNOSIS >

[XENON TYPE]

SYMPTOM DIAGNOSIS

EXTERIOR LIGHTING SYSTEM SYMPTOMS

Symptom Table

INFOID:000000005460890

CAUTION:

Perform the self-diagnosis with CONSULT-III before the symptom diagnosis. Perform the trouble diagnosis if any DTC is detected.

Symptom		Possible cause	Inspection item
Headlamp does not switch to the high beam.	One side	<ul style="list-style-type: none"> • Fuse • Harness between IPDM E/R and the front combination lamp • Front combination lamp (High beam relay) • IPDM E/R 	Headlamp (HI) circuit. Refer to EXL-37 .
	Both sides	Symptom diagnosis "BOTH SIDE HEADLAMPS DO NOT SWITCH TO HIGH BEAM" Refer to EXL-155 .	
High beam indicator lamp is not turned ON. (Headlamp switches to the high beam.)		<ul style="list-style-type: none"> • Combination meter • BCM 	<ul style="list-style-type: none"> • Combination meter. Data monitor "HI-BEAM IND". • BCM (HEAD LAMP). Active test "HEADLAMP".
Headlamp does not switch to the low beam.	One side	Front combination lamp (Low beam relay)	—
	Both sides	<ul style="list-style-type: none"> • Combination switch • Harness between the combination switch and BCM • BCM 	Combination switch. Refer to BCS-10 .
		<ul style="list-style-type: none"> • High beam request signal • BCM • IPDM E/R 	IPDM E/R. Data monitor "HL HI REQ".
		IPDM E/R	—
Headlamp does not turn ON.	One side	<ul style="list-style-type: none"> • Fuse • Bulb • Harness between IPDM E/R and the front combination lamp • Front combination lamp • IPDM E/R 	Headlamp (LO) circuit. Refer to EXL-39 .
	Both sides	Symptom diagnosis "BOTH SIDE HEADLAMPS (LO) ARE NOT TURNED ON" Refer to EXL-156 , " Description ".	
Headlamp does not turn OFF.	When the ignition switch is turned ON	<ul style="list-style-type: none"> • BCM • Combination switch 	Combination switch. Refer to BCS-10 .
	The ignition switch is turned OFF (After activating the battery saver).	IPDM E/R	—
Headlamp is not turned ON/OFF with the lighting switch AUTO.		<ul style="list-style-type: none"> • Combination switch • Harness between the combination switch and BCM • BCM 	Combination switch. Refer to BCS-10 .
		<ul style="list-style-type: none"> • Optical sensor • Harness between the optical sensor and BCM • BCM 	Optical sensor. Refer to EXL-50 .

EXTERIOR LIGHTING SYSTEM SYMPTOMS

< SYMPTOM DIAGNOSIS >

[XENON TYPE]

Symptom	Possible cause	Inspection item	
Daytime light system does not activate.	<ul style="list-style-type: none"> • Either high beam bulb • Parking brake switch • Combination switch • BCM • IPDM E/R • Daytime light relay • Harness between IPDM E/R and daytime light relay. 	Daytime light system description. Refer to EXL-11 , " System Description ".	
Front fog lamp is not turned ON.	One side	<ul style="list-style-type: none"> • Front fog lamp bulb • Harness between IPDM E/R and the front combination lamp • Front combination lamp • IPDM E/R Front fog lamp circuit. Refer to EXL-41 .	
	Both side	Symptom diagnosis "BOTH SIDE FRONT FOG LAMPS ARE NOT TURNED ON" Refer to EXL-158 .	
Parking lamp is not turned ON.	One side	<ul style="list-style-type: none"> • Fuse • Parking lamp bulb • Harness between IPDM E/R and the front/rear combination lamp • Front/rear combination lamp • IPDM E/R Parking lamp circuit. Refer to EXL-43 .	
	Both sides	Symptom diagnosis "PARKING, LICENSE PLATE AND TAIL LAMPS ARE NOT TURNED ON". Refer to EXL-157 .	
Turn signal lamp does not blink.	Indicator lamp is normal. (The applicable side performs the high flasher activation).	<ul style="list-style-type: none"> • Harness between BCM and each turn signal lamp • Turn signal lamp bulb • Door mirror (if equipped with turn signals in the door mirrors) Turn signal lamp circuit. Refer to EXL-47 .	
Turn signal indicator lamp does not blink.	One side	Combination meter	
	Both sides (Always)	<ul style="list-style-type: none"> • Turn signal indicator lamp signal • Combination meter • BCM 	<ul style="list-style-type: none"> • Combination meter. Data monitor "TURN IND". • BCM (FLASHER). Active test "FLASHER".
	Both sides (Does blink when activating the hazard warning lamp with the ignition switch OFF)	<ul style="list-style-type: none"> • The combination meter power supply and the ground circuit • Combination meter 	Combination meter. Power supply and the ground circuit Refer to MWI-37 .

A
B
C
D
E
F
G
H
I
J
K
M
N
O
P

EXL

NORMAL OPERATING CONDITION

< SYMPTOM DIAGNOSIS >

[XENON TYPE]

NORMAL OPERATING CONDITION

Description

INFOID:000000005460891

XENON HEADLAMP

- The brightness and color of the light may vary slightly immediately after turning the headlamp ON. This condition will remain until the xenon bulb becomes stable. This is normal.
- Illumination time lag may occur between right and left. This is normal.

AUTO LIGHT SYSTEM

The auto light system may not turn the headlamp ON/OFF immediately after passing a dark area or a bright area (short tunnel, sky bridge, shadowed area etc.). This is normal.

BOTH SIDE HEADLAMPS DO NOT SWITCH TO HIGH BEAM

< SYMPTOM DIAGNOSIS >

[XENON TYPE]

BOTH SIDE HEADLAMPS DO NOT SWITCH TO HIGH BEAM

Description

INFOID:000000005460892

The headlamps (both sides) do not switch to high beam when the lighting switch is in the HI or PASS setting.

Diagnosis Procedure

INFOID:000000005460893

1.COMBINATION SWITCH INSPECTION

Check the combination switch. Refer to [EXL-21, "System Description"](#).

Is the combination switch normal?

YES >> GO TO 2.

NO >> Repair or replace the malfunctioning part.

2.CHECK HEADLAMP (HI) REQUEST SIGNAL INPUT

 CONSULT-III DATA MONITOR

1. Select "HL HI REQ" of IPDM E/R DATA MONITOR item.
2. While operating the lighting switch, check the monitor status.

Monitor item	Condition		Monitor status
HL HI REQ	Lighting switch (2ND)	HI or PASS	ON
		Except for HI or PASS	OFF

Is the item status normal?

YES >> GO TO 3.

NO >> Replace BCM. Refer to [BCS-87, "Removal and Installation"](#).

3.HEADLAMP (HI) CIRCUIT INSPECTION

Check the headlamp (HI) circuit. Refer to [EXL-37, "Diagnosis Procedure"](#).

Is the headlamp (HI) circuit normal?

YES >> Replace IPDM E/R. Refer to [PCS-41, "Removal and Installation"](#).

NO >> Repair or replace the malfunctioning part.

A
B
C
D
E
F
G
H
I
J
K

EXL

M
N
O
P

BOTH SIDE HEADLAMPS (LO) ARE NOT TURNED ON

< SYMPTOM DIAGNOSIS >

[XENON TYPE]

BOTH SIDE HEADLAMPS (LO) ARE NOT TURNED ON

Description

INFOID:000000005460894

The headlamps (both sides) do not turn ON in any lighting switch setting.

Diagnosis Procedure

INFOID:000000005460895

1. CHECK COMBINATION SWITCH

Check the combination switch. Refer to [EXL-21, "System Description"](#).

Is the combination switch normal?

YES >> GO TO 2.

NO >> Repair or replace the malfunctioning part.

2. CHECK HEADLAMP (LO) REQUEST SIGNAL INPUT

Ⓟ CONSULT-III DATA MONITOR

1. Select "HL LO REQ" of IPDM E/R DATA MONITOR item.
2. While operating the lighting switch, check the monitor status.

Monitor item	Condition	Monitor status	
HL LO REQ	Lighting switch	2ND	ON
		OFF	OFF

Is the item status normal?

YES >> GO TO 3.

NO >> Replace BCM. Refer to [BCS-87, "Removal and Installation"](#).

3. HEADLAMP (LO) CIRCUIT INSPECTION

Check the headlamp (LO) circuit. Refer to [EXL-39, "Diagnosis Procedure"](#).

Is the headlamp (LO) circuit normal?

YES >> Replace IPDM E/R. Refer to [PCS-41, "Removal and Installation"](#).

NO >> Repair or replace the malfunctioning part.

PARKING, LICENSE PLATE AND TAIL LAMPS ARE NOT TURNED ON

< SYMPTOM DIAGNOSIS >

[XENON TYPE]

PARKING, LICENSE PLATE AND TAIL LAMPS ARE NOT TURNED ON

Description

INFOID:000000005460896

The parking, license plate and tail lamps do not turn ON in with any lighting switch setting.

Diagnosis Procedure

INFOID:000000005460897

1.COMBINATION SWITCH INSPECTION

Check the combination switch. Refer to [EXL-21, "System Description"](#).

Is the combination switch normal?

YES >> GO TO 2.

NO >> Repair or replace the malfunctioning part.

2.CHECK TAIL LAMP RELAY REQUEST SIGNAL INPUT

ⓂCONSULT-III DATA MONITOR

1. Select "TAIL & CLR REQ" of IPDM E/R DATA MONITOR item.
2. While operating the lighting switch, check the monitor status.

Monitor item	Condition	Monitor status	
TAIL & CLR REQ	Lighting switch	1ST	ON
		OFF	OFF

Is the item status normal?

YES >> GO TO 3.

NO >> Replace BCM. Refer to [BCS-87, "Removal and Installation"](#).

3.PARK LAMP CIRCUIT INSPECTION

Check the parking lamp circuit. Refer to [EXL-43, "Diagnosis Procedure"](#).

Is the tail lamp circuit normal?

YES >> Replace IPDM E/R. Refer to [PCS-41, "Removal and Installation"](#).

NO >> Repair or replace the malfunctioning part.

A
B
C
D
E
F
G
H
I
J
K
M
N
O
P

EXL

BOTH SIDE FRONT FOG LAMPS ARE NOT TURNED ON

< SYMPTOM DIAGNOSIS >

[XENON TYPE]

BOTH SIDE FRONT FOG LAMPS ARE NOT TURNED ON

Description

INFOID:000000005460898

The front fog lamps do not turn ON in any setting.

Diagnosis Procedure

INFOID:000000005460899

1.COMBINATION SWITCH INSPECTION

Check the combination switch. Refer to [EXL-21, "System Description"](#).

Is the combination switch normal?

YES >> GO TO 2.

NO >> Repair or replace the malfunctioning part.

2.CHECK FRONT FOG LAMP REQUEST SIGNAL INPUT

ⓅCONSULT-III DATA MONITOR

1. Select "FR FOG REQ" of IPDM E/R DATA MONITOR item.
2. While operating the front fog lamp switch, check the monitor status.

Monitor item	Condition	Monitor status	
FR FOG REQ	Front fog lamp switch (Lighting switch 2ND)	ON	ON
		OFF	OFF

Is the item status normal?

YES >> GO TO 3.

NO >> Replace BCM. Refer to [BCS-87, "Removal and Installation"](#).

3.FRONT FOG LAMP CIRCUIT INSPECTION

Check the front fog lamp circuit. Refer to [EXL-41, "Diagnosis Procedure"](#).

Is the front fog lamp circuit normal?

YES >> Replace IPDM E/R. Refer to [PCS-41, "Removal and Installation"](#).

NO >> Repair or replace the malfunctioning part.

PRECAUTION

PRECAUTIONS

Precaution for Supplemental Restraint System (SRS) "AIR BAG" and "SEAT BELT PRE-TENSIONER"

INFOID:000000005460900

The Supplemental Restraint System such as "AIR BAG" and "SEAT BELT PRE-TENSIONER", used along with a front seat belt, helps to reduce the risk or severity of injury to the driver and front passenger for certain types of collision. This system includes seat belt switch inputs and dual stage front air bag modules. The SRS system uses the seat belt switches to determine the front air bag deployment, and may only deploy one front air bag, depending on the severity of a collision and whether the front occupants are belted or unbelted. Information necessary to service the system safely is included in the SR and SB section of this Service Manual.

WARNING:

- To avoid rendering the SRS inoperative, which could increase the risk of personal injury or death in the event of a collision which would result in air bag inflation, all maintenance must be performed by an authorized NISSAN/INFINITI dealer.
- Improper maintenance, including incorrect removal and installation of the SRS, can lead to personal injury caused by unintentional activation of the system. For removal of Spiral Cable and Air Bag Module, see the SR section.
- Do not use electrical test equipment on any circuit related to the SRS unless instructed to in this Service Manual. SRS wiring harnesses can be identified by yellow and/or orange harnesses or harness connectors.

PRECAUTIONS WHEN USING POWER TOOLS (AIR OR ELECTRIC) AND HAMMERS

WARNING:

- When working near the Airbag Diagnosis Sensor Unit or other Airbag System sensors with the Ignition ON or engine running, DO NOT use air or electric power tools or strike near the sensor(s) with a hammer. Heavy vibration could activate the sensor(s) and deploy the air bag(s), possibly causing serious injury.
- When using air or electric power tools or hammers, always switch the Ignition OFF, disconnect the battery, and wait at least 3 minutes before performing any service.

Precautions For Xenon Headlamp Service

INFOID:000000005460901

WARNING:

Comply with the following warnings to prevent any serious accident.

- Disconnect the battery cable (negative terminal) or the power supply fuse before installing, removing, or touching the xenon headlamp (bulb included). The xenon headlamp contains high-voltage generated parts.
- Never work with wet hands.
- Check the xenon headlamp ON-OFF status after assembling it to the vehicle. Never turn the xenon headlamp ON in other conditions. Connect the power supply to the vehicle-side connector.
(Turning it ON outside the lamp case may cause fire or visual impairments.)
- Never touch the bulb glass immediately after turning it OFF. It is extremely hot.



CAUTION:

Comply with the following cautions to prevent any error and malfunction.

A
B
C
D
E
F
G
H
I
J
K
EXL
M
N
O
P

PRECAUTIONS

< PRECAUTION >

[XENON TYPE]

- Install the xenon bulb securely. (Insufficient bulb socket installation may melt the bulb, the connector, the housing, etc, by high-voltage leakage or corona discharge.)
- Never perform HID circuit inspection with a tester.
- Never touch the xenon bulb glass with hands. Never put oil and grease on it.
- Dispose of the used xenon bulb after packing it in thick vinyl without breaking it.
- Never wipe out dirt and contamination with organic solvent (thinner, gasoline, etc.).

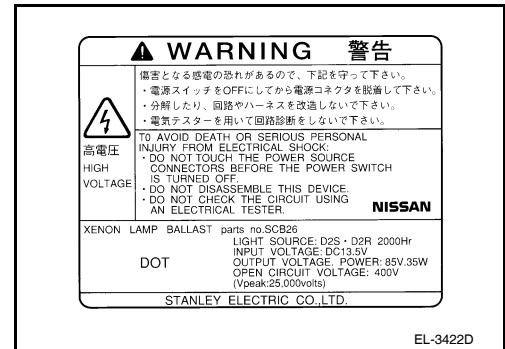

Precautions Necessary for Steering Wheel Rotation after Battery Disconnect (Early Production, With Electronic Steering Column Lock)

INFOID:000000005885952

NOTE:

- Before removing and installing any control units, first turn the push-button ignition switch to the LOCK position, then disconnect both battery cables.
- After finishing work, confirm that all control unit connectors are connected properly, then re-connect both battery cables.
- Always use CONSULT-III to perform self-diagnosis as a part of each function inspection after finishing work. If a DTC is detected, perform trouble diagnosis according to self-diagnosis results.

This vehicle is equipped with a push-button ignition switch and a steering lock unit.

If the battery is disconnected or discharged, the steering wheel will lock and cannot be turned.

If turning the steering wheel is required with the battery disconnected or discharged, follow the procedure below before starting the repair operation.

OPERATION PROCEDURE

1. Connect both battery cables.

NOTE:

Supply power using jumper cables if battery is discharged.

2. Carry the Intelligent Key or insert it to the key slot and turn the push-button ignition switch to ACC position. (At this time, the steering lock will be released.)
3. Disconnect both battery cables. The steering lock will remain released with both battery cables disconnected and the steering wheel can be turned.
4. Perform the necessary repair operation.
5. When the repair work is completed, re-connect both battery cables. With the brake pedal released, turn the push-button ignition switch from ACC position to ON position, then to LOCK position. (The steering wheel will lock when the push-button ignition switch is turned to LOCK position.)
6. Perform self-diagnosis check of all control units using CONSULT-III.

General precautions for service operations

INFOID:000000005460903

- Turn the lighting switch OFF before disconnecting and connecting the connector.
- When checking the headlamp on/off operation, check it on vehicle and with the power connected to the vehicle-side connector.
- Leaving the bulb removed from the headlamp housing for a long period of time can deteriorate the performance of the lens and reflector (dirt, clouding). Always prepare a new bulb and have it on hand when replacing the bulb.
- When adjusting the headlamp aiming, turn the aiming adjustment screw only in the tightening direction. (If it is necessary to loosen the screw, first fully loosen the screw, and then turn it in the tightening direction.)

HEADLAMP AIMING ADJUSTMENT

< ON-VEHICLE MAINTENANCE >

[XENON TYPE]

ON-VEHICLE MAINTENANCE

HEADLAMP AIMING ADJUSTMENT

Description

INFOID:000000005460904

PREPARATION BEFORE ADJUSTING

NOTE:

- For details, refer to the regulations in your area.
- Perform aiming adjustment if the vehicle front body has been repaired and/or the front combination lamp assembly has been replaced.

Before performing aiming adjustment, check the following.

- Adjust the tire pressure to specification.
- Position vehicle and screen on level surface.
- Ensure there is no load in vehicle other than the driver (or equivalent weight placed in driver's position).
- Ensure engine coolant and engine oil are filled to correct levels and fuel tank is full.
- Confirm spare tire, jack and tools are properly stowed.
- Wipe off dirt on the headlamp.

CAUTION:

Never use organic solvent (thinner, gasoline etc.).

AIMING ADJUSTMENT SCREW

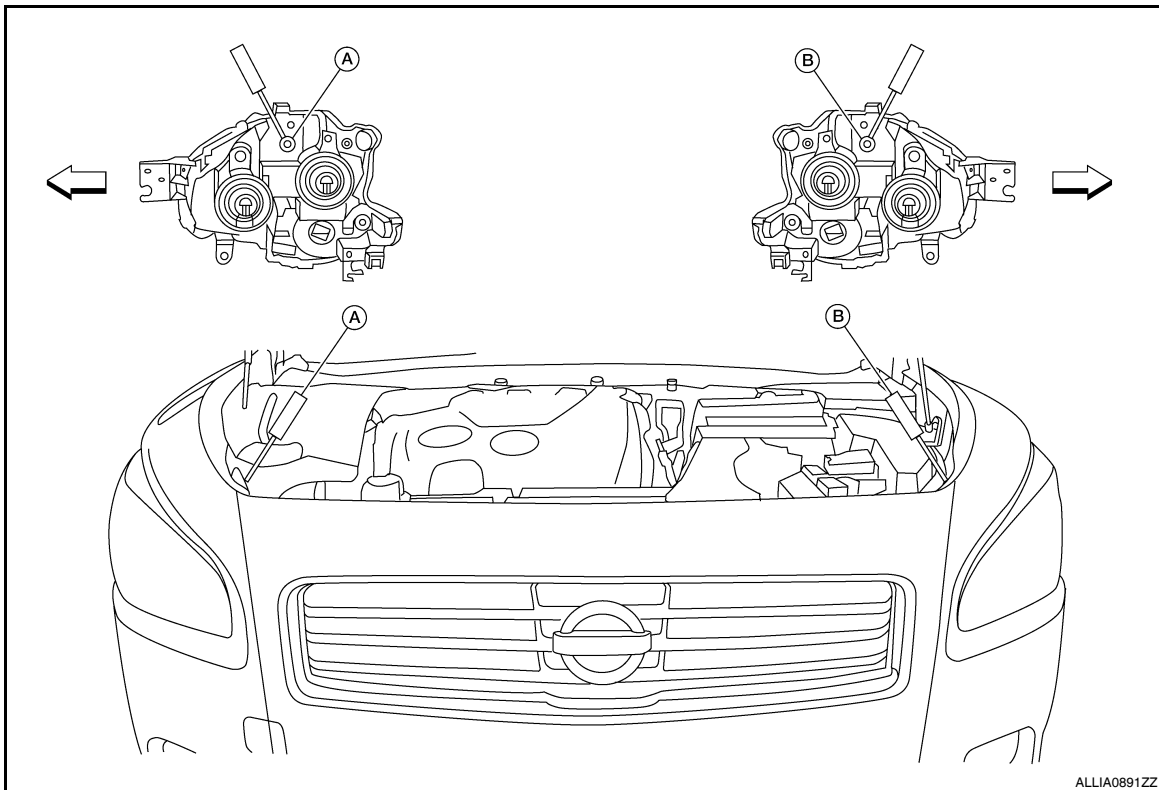

A. Headlamp RH (UP/DOWN) adjustment screw

B. Headlamp LH (UP/DOWN) adjustment screw

← Vehicle center

Adjustment screw		Screw driver rotation	Facing direction
A	Headlamp RH (UP/DOWN)	Clockwise	DOWN
		Counterclockwise	UP
B	Headlamp LH (UP/DOWN)	Clockwise	DOWN
		Counterclockwise	UP

HEADLAMP AIMING ADJUSTMENT

< ON-VEHICLE MAINTENANCE >

[XENON TYPE]

INFOID:000000005460905

Aiming Adjustment Procedure

1. Position the screen.

NOTE:

- Stop the vehicle facing the screen.
- Place the screen on a plain road vertically.

2. Face the screen with the vehicle. Maintain 7.62 m (25 ft) between the headlamp bulb center and the screen.

3. Start the engine. Turn the headlamp (LO) ON.

CAUTION:

Never cover the lens surface with tape, etc. The lens is made of resin.

NOTE:

- Aim each headlamp individually and ensure other headlamp beam pattern is blocked from screen.
- For horizontal aiming, adjust headlamp until beam pattern is at horizontal center point.

Adjustment Using An Adjustment Screen (Light/Dark Borderline)

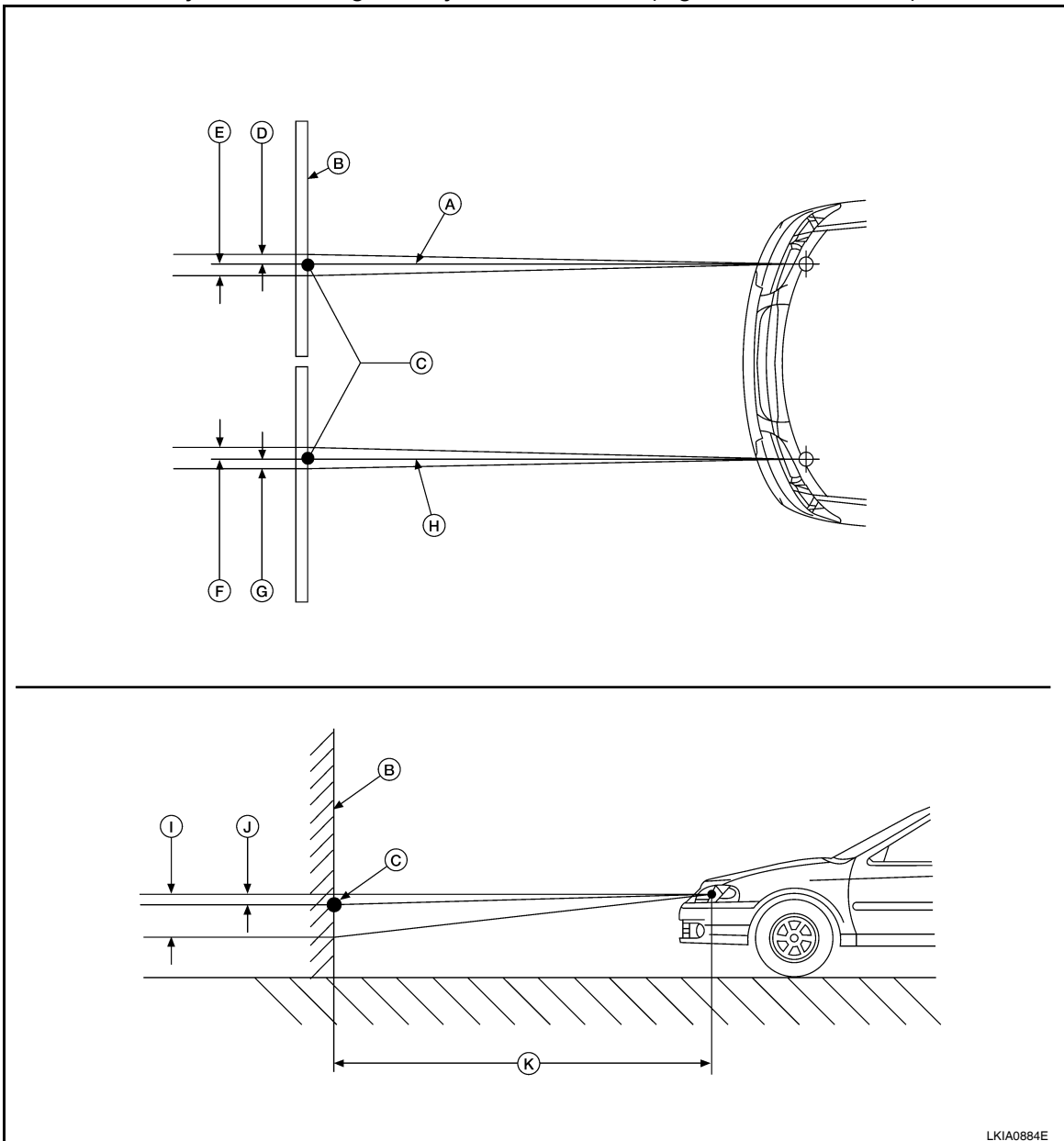

LKIA0884E

A. Headlamp beam (RH)

B. Screen

C. Horizontal/Vertical center point of headlamp

D. 66.5 mm (2.6 in)

E. 66.5 mm (2.6 in)

F. 66.5 mm (2.6 in)

HEADLAMP AIMING ADJUSTMENT

< ON-VEHICLE MAINTENANCE >

[XENON TYPE]

G. 66.5 mm (2.6 in)
J. 13.3 mm (0.5 in)

H. Headlamp beam (LH)
K. 7.62 m (25 ft)

I. 53.2 mm (2.1 in)

A
B
C
D
E
F
G
H
I
J
K
EXL
M
N
O
P

FRONT FOG LAMP AIMING ADJUSTMENT

< ON-VEHICLE MAINTENANCE >

[XENON TYPE]

FRONT FOG LAMP AIMING ADJUSTMENT

Description

INFOID:000000005460906

PREPARATION BEFORE ADJUSTING

NOTE:

For details, refer to the regulations in your area.

Before performing aiming adjustment, check the following.

- Adjust the tire pressure to specification.
- Position vehicle and screen on level surface.
- Ensure there is no load in vehicle other than the driver (or equivalent weight placed in driver's position).
- Ensure engine coolant and engine oil are filled to correct levels and fuel tank is full.
- Confirm spare tire, jack and tools are properly stowed.
- Wipe off dirt on the headlamp.

CAUTION:

Never use organic solvent (thinner, gasoline etc.).

AIMING ADJUSTMENT SCREW

- Turn the aiming adjusting screw for adjustment as shown.

NOTE:

A screwdriver or hexagonal wrench [6 mm (0.24 in)] can be used for adjustment.

- A: Up
- B: Down

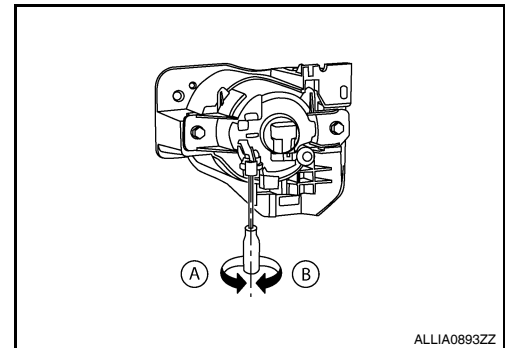

Aiming Adjustment Procedure

INFOID:000000005460907

1. Position the screen.

NOTE:

- Stop the vehicle facing the screen.
- Place the screen on a plain road vertically.

2. Face the screen with the vehicle. Maintain 7.62 m (25.0 ft) between the front fog lamp center and the screen.

3. Start the engine. Turn the front fog lamp ON.

CAUTION:

Never cover the lens surface with tape, etc. The lens is made of resin.

NOTE:

- Aim each fog lamp individually and ensure other fog lamp beam pattern is blocked from screen.

4. Adjust the cutoff line height (A) with the aiming adjustment screw so that the distance (X) between the horizontal center line of front fog lamp (H) and (A) becomes 100 mm (4.0 in).

- Front fog lamp light distribution on the screen is as shown.

- A: Cutoff line
- B: High illuminance area
- H: Horizontal center line of front fog lamp
- V: Vertical center line of front fog lamp
- X: Cutoff line height

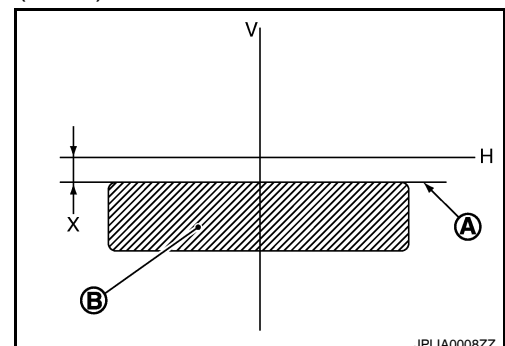

FRONT COMBINATION LAMP

< ON-VEHICLE REPAIR >

[XENON TYPE]

ON-VEHICLE REPAIR

FRONT COMBINATION LAMP

Exploded View

INFOID:000000005460908

REMOVAL

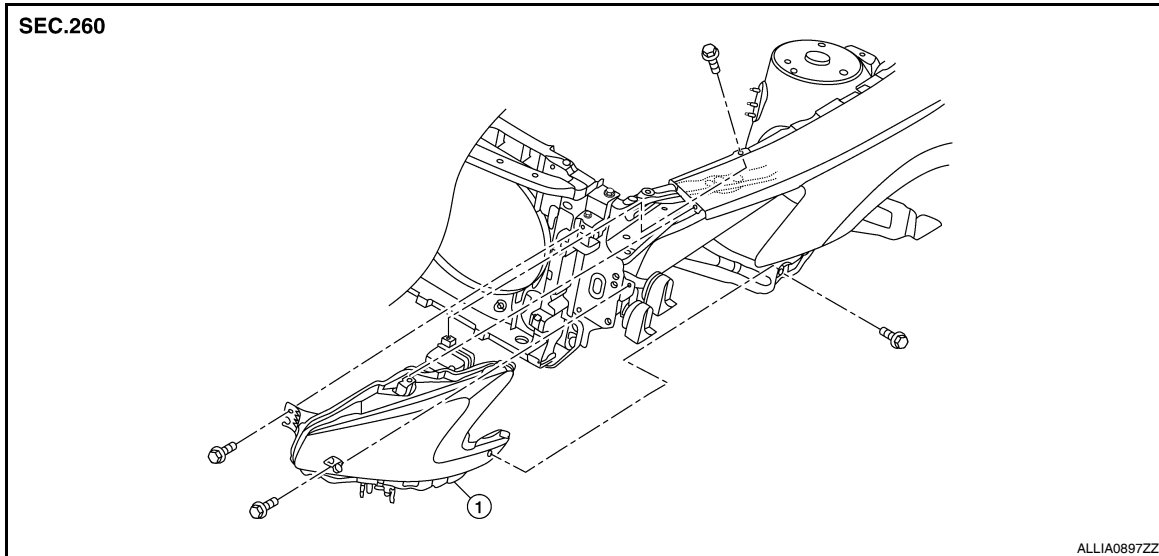

1. Front combination lamp

DISASSEMBLY

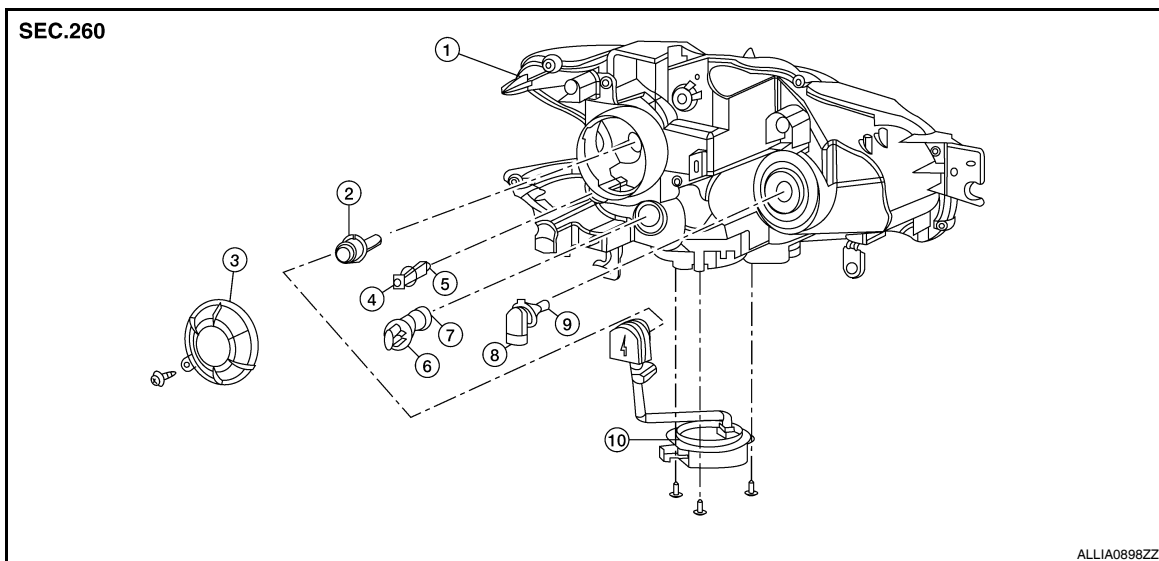

- | | | |
|--|------------------------------------|----------------------------------|
| 1. Front combination lamp | 2. Xenon bulb | 3. Plastic cover |
| 4. Side marker lamp socket | 5. Side marker lamp bulb | 6. Front turn signal lamp socket |
| 7. Front turn signal lamp bulb | 8. Halogen bulb socket (high beam) | 9. Halogen bulb (high beam) |
| 10. HID control unit and xenon bulb socket | | |

Removal and Installation

INFOID:000000005460909

REMOVAL

CAUTION:

FRONT COMBINATION LAMP

< ON-VEHICLE REPAIR >

[XENON TYPE]

Disconnect the battery negative terminal or remove the fuse.

1. Remove the front bumper fascia. Refer to [EXT-14, "Removal and Installation"](#).
2. Remove the front combination lamp bolts.
3. Remove the harness clips from the front combination lamp assembly.
4. Pull out the front combination lamp toward the front of vehicle.
5. Disconnect the harness connectors before removing the front combination lamp.

INSTALLATION

Installation is in the reverse order of removal.

NOTE:

After installation, perform headlamp aiming adjustment. Refer to [EXL-161, "Description"](#).

Replacement

INFOID:000000005460910

WARNING:

- Never touch bulb by hand while it is lit or right after being turned off.

CAUTION:

- Disconnect the battery negative terminal or remove the fuse.
- After installing the bulb, install the plastic cover and the bulb socket securely for watertightness.
- Never touch the glass of bulb directly by hand. Keep grease and other oily matters away from it.
- Never leave bulb out of lamp reflector for a long time because dust, moisture, smoke, etc., may affect the performance of lamp. When replacing bulb, be sure to replace it with new one.

XENON BULB

1. Remove the front combination lamp. Refer to [EXL-165, "Removal and Installation"](#).
2. Remove screw from cover and rotate the plastic cover counterclockwise and unlock it.
3. Rotate the xenon bulb socket counterclockwise and unlock it.
4. Unlock the retaining spring and remove the xenon bulb from the front combination lamp.

CAUTION:

Never break the xenon bulb ceramic tube when replacing the bulb.

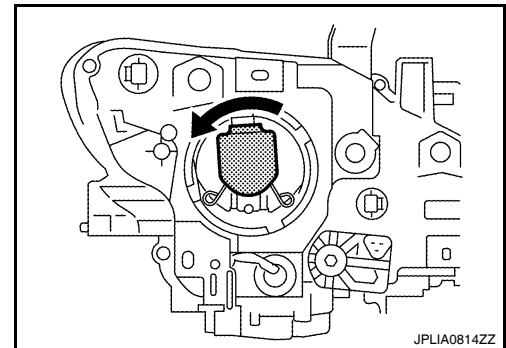

HALOGEN BULB (HIGH BEAM)

1. Remove the front combination lamp. Refer to [EXL-165, "Removal and Installation"](#).
2. Rotate the bulb socket counterclockwise and unlock it.
3. Remove the bulb from the bulb socket.

FRONT TURN SIGNAL LAMP BULB

1. Remove the front combination lamp. Refer to [EXL-165, "Removal and Installation"](#).
2. Rotate the bulb socket counterclockwise and unlock it.
3. Remove the bulb from the bulb socket.

FRONT SIDE MARKER LAMP BULB

1. Remove the front combination lamp. Refer to [EXL-165, "Removal and Installation"](#).
2. Rotate the bulb socket counterclockwise and unlock it.
3. Remove the bulb from the bulb socket.

Disassembly and Assembly

INFOID:000000005460911

DISASSEMBLY

1. Remove screw from cover and rotate the plastic cover counterclockwise and unlock it.

FRONT COMBINATION LAMP

< ON-VEHICLE REPAIR >

[XENON TYPE]

2. Rotate the xenon bulb socket counterclockwise and unlock it.
3. Unlock the retaining spring and remove the xenon bulb.
4. Remove the HID control unit installation screws.
5. Remove the screw and disconnect the harness connector from the HID control unit.
6. Remove the xenon bulb socket from front combination lamp.
7. Rotate the halogen bulb socket counterclockwise and unlock it.
8. Remove the bulb from halogen bulb socket.
9. Rotate the front turn signal lamp socket counterclockwise and unlock it.
10. Remove the bulb from front turn signal lamp socket.
11. Rotate the front side marker lamp socket counterclockwise and unlock it.
12. Remove the bulb from front side marker lamp socket.

A
B
C
D

ASSEMBLY

Assembly is in the reverse order of disassembly.

CAUTION:

- **Install HID control unit securely.**
- **After installing the bulb, install the plastic cover and the bulb socket securely for watertightness.**

E
F
G
H
I
J
K

EXL

M
N
O
P

FRONT FOG LAMP

< ON-VEHICLE REPAIR >

[XENON TYPE]

FRONT FOG LAMP

Exploded View

INFOID:000000005460912

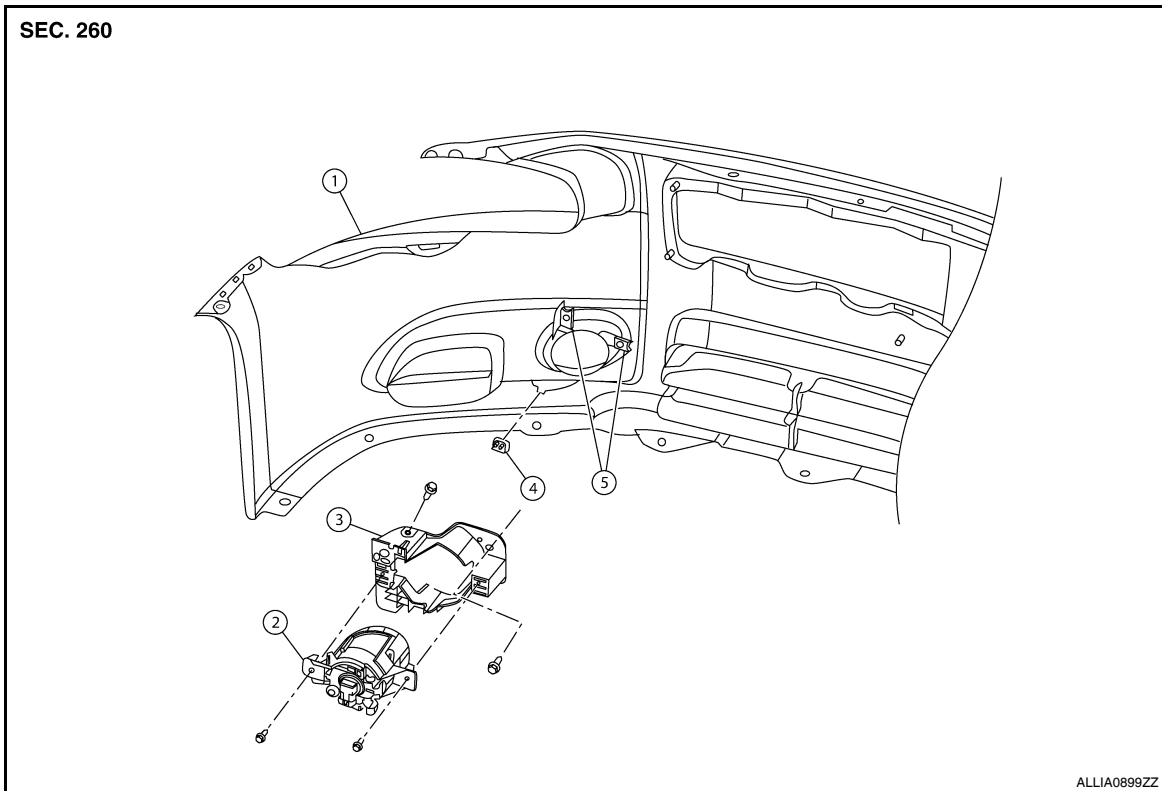

- | | | |
|------------------------|-------------------|---------------------------|
| 1. Front bumper fascia | 2. Front fog lamp | 3. Front fog lamp bracket |
| 4. Clip | 5. Spring nuts | |

Removal and Installation

INFOID:000000005460913

REMOVAL

1. Remove the front bumper fascia. Refer to [EXT-14, "Removal and Installation"](#).
2. Disconnect the front fog lamp harness connector.
3. Remove the front fog lamp bolts.
4. Remove the front fog lamp.

INSTALLATION

Installation is in the reverse order of removal.

NOTE:

After installation, perform front fog lamp aiming adjustment. Refer to [EXL-164, "Description"](#)

Replacement

INFOID:000000005460914

WARNING:

- Never touch bulb by hand while it is lit or right after being turned off.

CAUTION:

- Never touch the glass of bulb directly by hand. Keep grease and other oily matters away from it.
- Never leave bulb out of lamp reflector for a long time because dust, moisture smoke, etc., may affect the performance of lamp. When replacing bulb, be sure to replace it with new one.

FRONT FOG LAMP BULB

1. Remove the front fender protector. Refer to [EXT-20, "Removal and Installation"](#).

FRONT FOG LAMP

< ON-VEHICLE REPAIR >

[XENON TYPE]

2. Disconnect the front fog lamp harness connector (1).
3. Rotate the bulb (2) counterclockwise and unlock it.

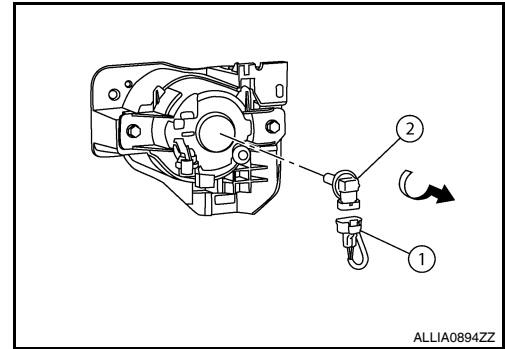

A
B
C
D
E
F
G
H
I
J
K
EXL
M
N
O
P

OPTICAL SENSOR

< ON-VEHICLE REPAIR >

[XENON TYPE]

OPTICAL SENSOR

Exploded View

INFOID:000000005460915

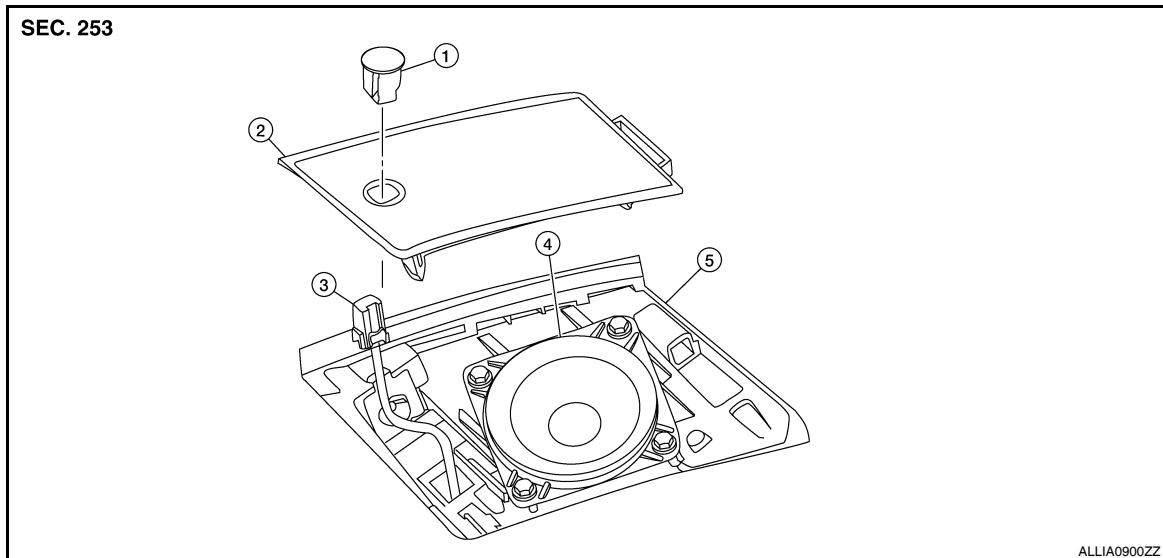

- | | | |
|---------------------|----------------------------|-------------------------------------|
| 1. Optical sensor | 2. LH front speaker grille | 3. Optical sensor harness connector |
| 4. LH front speaker | 5. Instrument panel | |

Removal and Installation

INFOID:000000005460916

REMOVAL

1. Remove the LH front speaker grille.
2. Insert an appropriate tool between the optical sensor and the LH front speaker grille. Pull out the optical sensor upward.
3. Disconnect the optical sensor harness connector and remove the optical sensor.

INSTALLATION

Installation is in the reverse order of removal.

LIGHTING & TURN SIGNAL SWITCH

< ON-VEHICLE REPAIR >

[XENON TYPE]

LIGHTING & TURN SIGNAL SWITCH

Removal and Installation

INFOID:000000005460917

NOTE:

The lighting and turn signal switch is integral with the combination switch assembly.

REMOVAL

1. Unlock steering wheel (early production, with electronic steering column lock).
2. Disconnect battery.
 - **CAUTION:**
 - **Before servicing, disconnect both battery terminals and wait at least three minutes.**
 - **Do not use air tools or electric tools for servicing.**
 - **After the work is completed, make sure no system malfunction is detected by air bag warning lamp.**
 - **In case a malfunction is detected by the air bag warning lamp, reset with the self-diagnosis function and delete the memory with CONSULT-III.**
 - **If a malfunction is still detected after the above operation, perform self-diagnosis to repair malfunctions. Refer to [SRC-12, "SRS Operation Check"](#).**
3. Remove steering column covers. Refer to [IP-11, "Exploded View"](#).
4. Rotate steering wheel clockwise to access first combination switch bolt. Remove bolt.
5. Rotate steering wheel counter-clockwise to access second combination switch bolt. Remove bolt, disconnect electrical connectors and combination switch.

INSTALLATION

Installation is in the reverse order of removal.

A
B
C
D
E
F
G
H
I
J
K
EXL
M
N
O
P

HAZARD SWITCH

< ON-VEHICLE REPAIR >

[XENON TYPE]

HAZARD SWITCH

Exploded View

INFOID:000000005460918

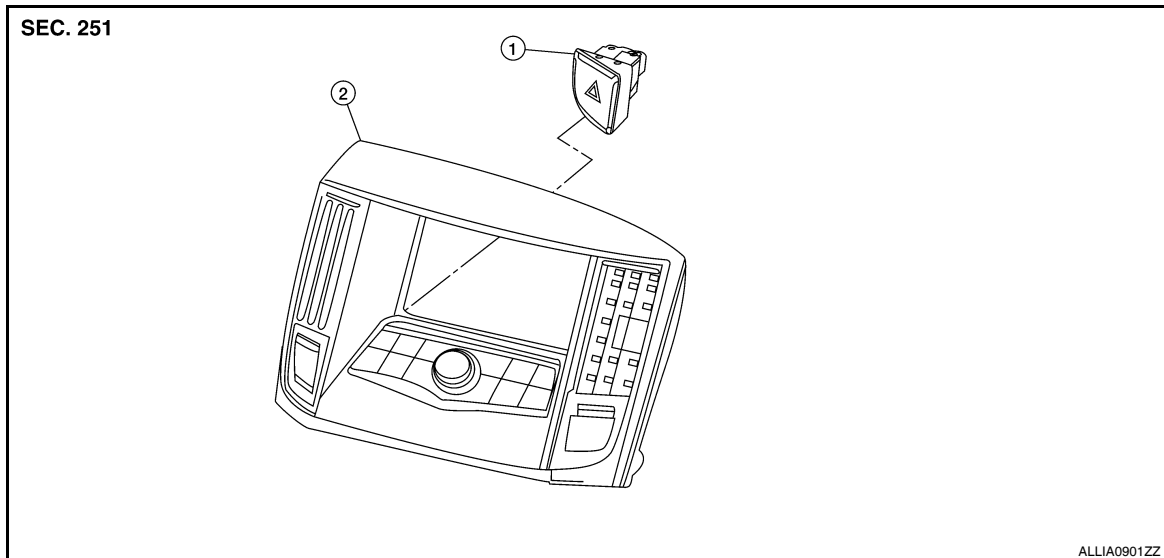

1. Hazard switch

2. Cluster lid D

Removal and Installation

INFOID:000000005460919

REMOVAL

1. Remove cluster lid D. Refer to [IP-11. "Exploded View"](#).
2. Disconnect the hazard switch harness connector.
3. Remove the hazard switch.

INSTALLATION

Installation is in the reverse order of removal.

REAR COMBINATION LAMP

< ON-VEHICLE REPAIR >

[XENON TYPE]

REAR COMBINATION LAMP

Exploded View

INFOID:000000005460920

REMOVAL

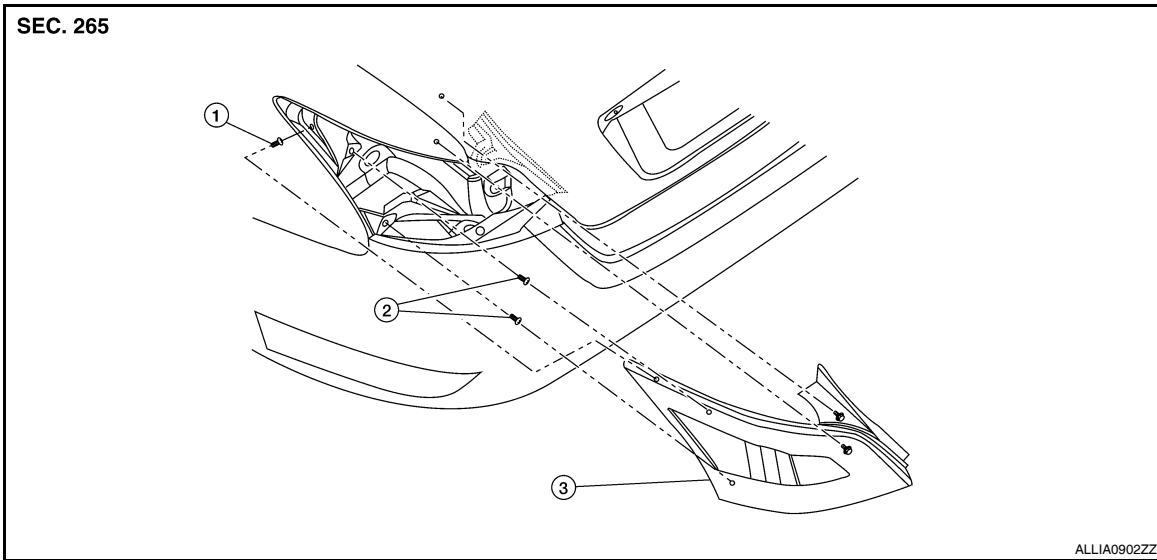

1. Slide clip 2. Grommets 3. Rear combination lamp

DISASSEMBLY

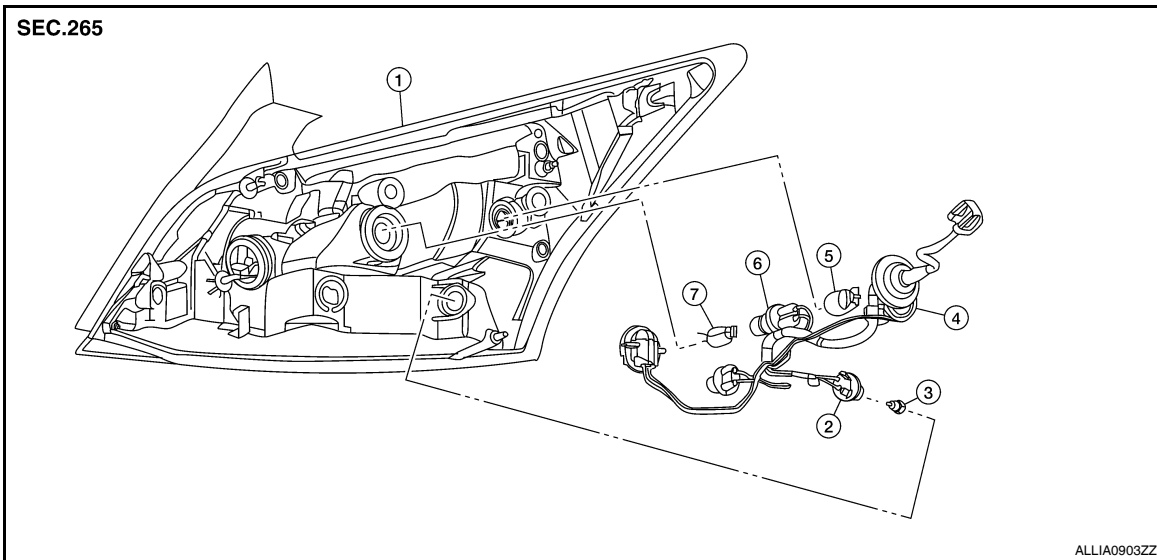

1. Rear combination lamp 2. Rear side marker lamp socket 3. Rear side marker lamp bulb
 4. Rear turn signal lamp socket 5. Rear turn signal lamp bulb 6. Back-up lamp socket
 7. Back-up lamp bulb

Removal and Installation

INFOID:000000005460921

REMOVAL

1. Remove the trunk side finisher. Refer to [INT-35, "Exploded View"](#).
2. Remove the rear combination lamp nuts.
3. Pull the rear combination lamp toward the rear of the vehicle to remove it.
4. Disconnect the rear combination lamp harness connector.

A
B
C
D
E
F
G
H
I
J
K
L
M
N
O
P

EXL

REAR COMBINATION LAMP

[XENON TYPE]

< ON-VEHICLE REPAIR >

INSTALLATION

Installation is in the reverse order of removal.

Replacement

INFOID:000000005460922

WARNING:

- Never touch bulb by hand while it is lit or right after being turned off.

CAUTION:

- Never touch the glass of bulb directly by hand. Keep grease and other oily matters away from it.
- Never leave bulb out of lamp reflector for a long time because dust, moisture smoke, etc. may affect the performance of lamp. When replacing bulb, be sure to replace it with new one.

STOP/TAIL LAMP

Replacement is integral with rear combination lamp. Refer to [EXL-173, "Exploded View"](#).

REAR SIDE MARKER LAMP BULB

1. Remove the rear combination lamp. Refer to [EXL-173, "Exploded View"](#).
2. Rotate the rear side marker lamp socket counterclockwise and unlock it.
3. Remove the bulb from the rear side marker lamp socket.

REAR TURN SIGNAL LAMP BULB

1. Remove the rear combination lamp. Refer to [EXL-173, "Exploded View"](#).
2. Rotate the rear turn signal lamp socket counterclockwise and unlock it.
3. Remove the bulb from the rear turn signal lamp socket.

BACK-UP LAMP BULB

1. Remove the rear combination lamp. Refer to [EXL-173, "Exploded View"](#).
2. Rotate the back-up lamp socket counterclockwise and unlock it.
3. Remove the bulb from the back-up lamp socket.

HIGH-MOUNTED STOP LAMP

< ON-VEHICLE REPAIR >

[XENON TYPE]

HIGH-MOUNTED STOP LAMP

Exploded View

INFOID:000000005460923

Models Without Rear Spoiler

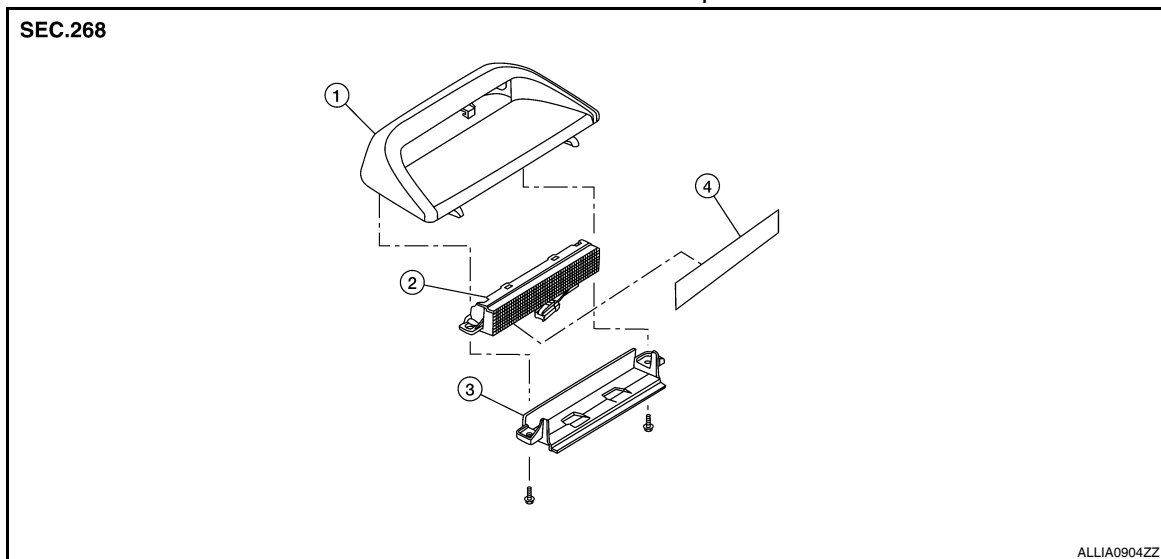

1. High-mounted stop lamp cover
2. High-mounted stop lamp bulb
3. High-mounted stop lamp bracket
4. Lens

Models With Rear Spoiler

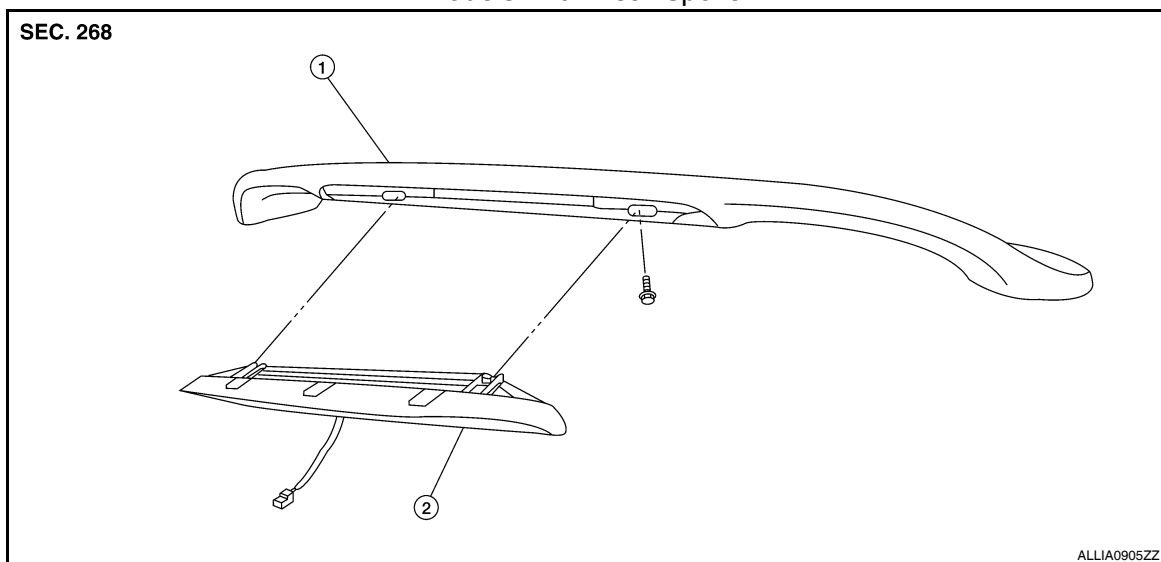

1. Rear spoiler
2. High-mounted stop lamp assembly

Removal and Installation

INFOID:000000005460924

WITHOUT REAR SPOILER

Removal

A
B
C
D
E
F
G
H
I
J
K
EXL
M
N
O
P

HIGH-MOUNTED STOP LAMP

< ON-VEHICLE REPAIR >

[XENON TYPE]

1. Slide the high-mounted stop lamp assembly rearward on the parcel shelf to give clearance to the front locking tabs.
2. Lift the front of the high-mounted stop lamp assembly up and slide it forward to give clearance to the rear locking tabs.
3. Disconnect the high-mounted stop lamp connector and remove.

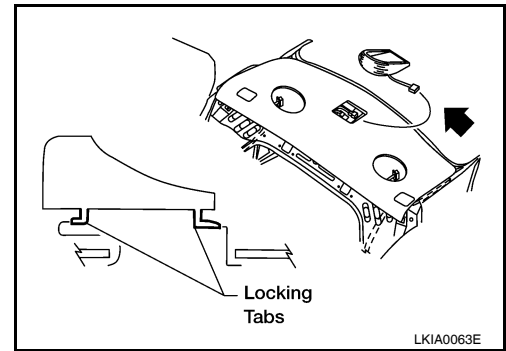

Installation

Installation is in the reverse order of removal.

WITH REAR SPOILER

Removal

1. Remove the high-mounted stop lamp assembly screws.
2. Remove the high-mounted stop lamp assembly from the rear spoiler.

Installation

Installation is in the reverse order of removal.

LICENSE PLATE LAMP

< ON-VEHICLE REPAIR >

[XENON TYPE]

LICENSE PLATE LAMP

Exploded View

INFOID:000000005460925

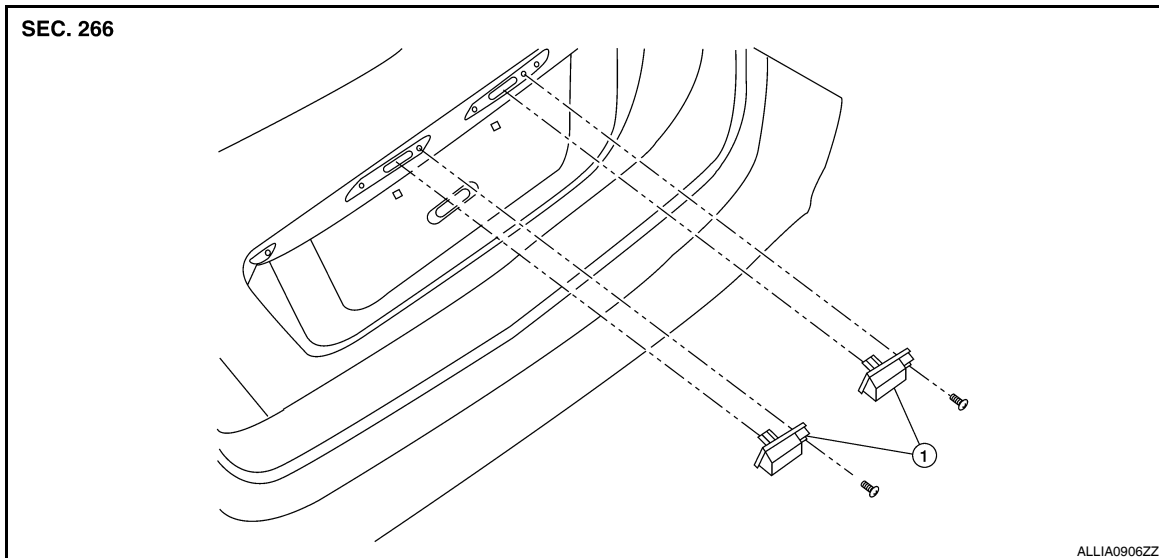

1. License plate lamp

Removal and Installation

INFOID:000000005460926

REMOVAL

1. Remove the license lamp finisher. Refer to [EXT-27, "Removal and Installation"](#).
2. Position trunk lid finisher aside. Refer to [INT-35, "Exploded View"](#).
3. Remove the license plate lamp screw and remove the license plate lamp.

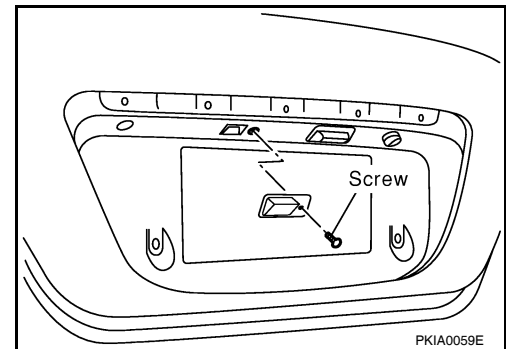

INSTALLATION

Installation is in the reverse order of removal.

Replacement

INFOID:000000005460927

WARNING:

- Never touch bulb by hand while it is lit or right after being turned off.

CAUTION:

- Never touch the glass of bulb directly by hand. Keep grease and other oily matters away from it.
- Never leave bulb out of lamp reflector for a long time because dust, moisture smoke, etc., may affect the performance of lamp. When replacing bulb, be sure to replace it with new one.

LICENSE PLATE LAMP BULB

1. Position trunk lid finisher aside. Refer to [INT-35, "Exploded View"](#).

A
B
C
D
E
F
G
H
I
J
K
EXL
M
N
O
P

LICENSE PLATE LAMP

< ON-VEHICLE REPAIR >

[XENON TYPE]

2. Turn the license plate lamp bulb socket counterclockwise and unlock it.
3. Remove the bulb from the license plate lamp bulb socket.

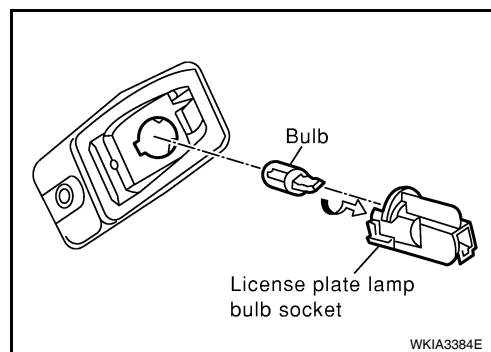

SERVICE DATA AND SPECIFICATIONS (SDS)

< SERVICE DATA AND SPECIFICATIONS (SDS)

[XENON TYPE]

SERVICE DATA AND SPECIFICATIONS (SDS)

SERVICE DATA AND SPECIFICATIONS (SDS)

Bulb Specifications

INFOID:000000005460928

Item	Type*	Wattage (W)
Front combination lamp	Headlamp (low beam)	D2S (Xenon) 35
	Headlamp (high beam)	9005/HB3 (Halogen) 65
	Park/Turn lamp	3457NAK 8/27
	Front side marker lamp	WY5W 5
Front fog lamp	H11 55	
Rear combination lamp	Stop lamp	LED —
	Tail lamp	LED —
	Rear turn signal lamp	WY21W 21
	Rear side marker lamp	W5W 5
	Back-up lamp	921 18
License plate lamp	168 5	
High-mounted stop lamp	Without rear spoiler	LED —
	With rear spoiler	LED —

*: Always check with the Parts Department for the latest parts information.

A
B
C
D
E
F
G
H
I
J
K
L
M
N
O
P

EXL

BASIC INSPECTION

DIAGNOSIS AND REPAIR WORKFLOW

Work Flow

INFOID:000000005460929

OVERALL SEQUENCE

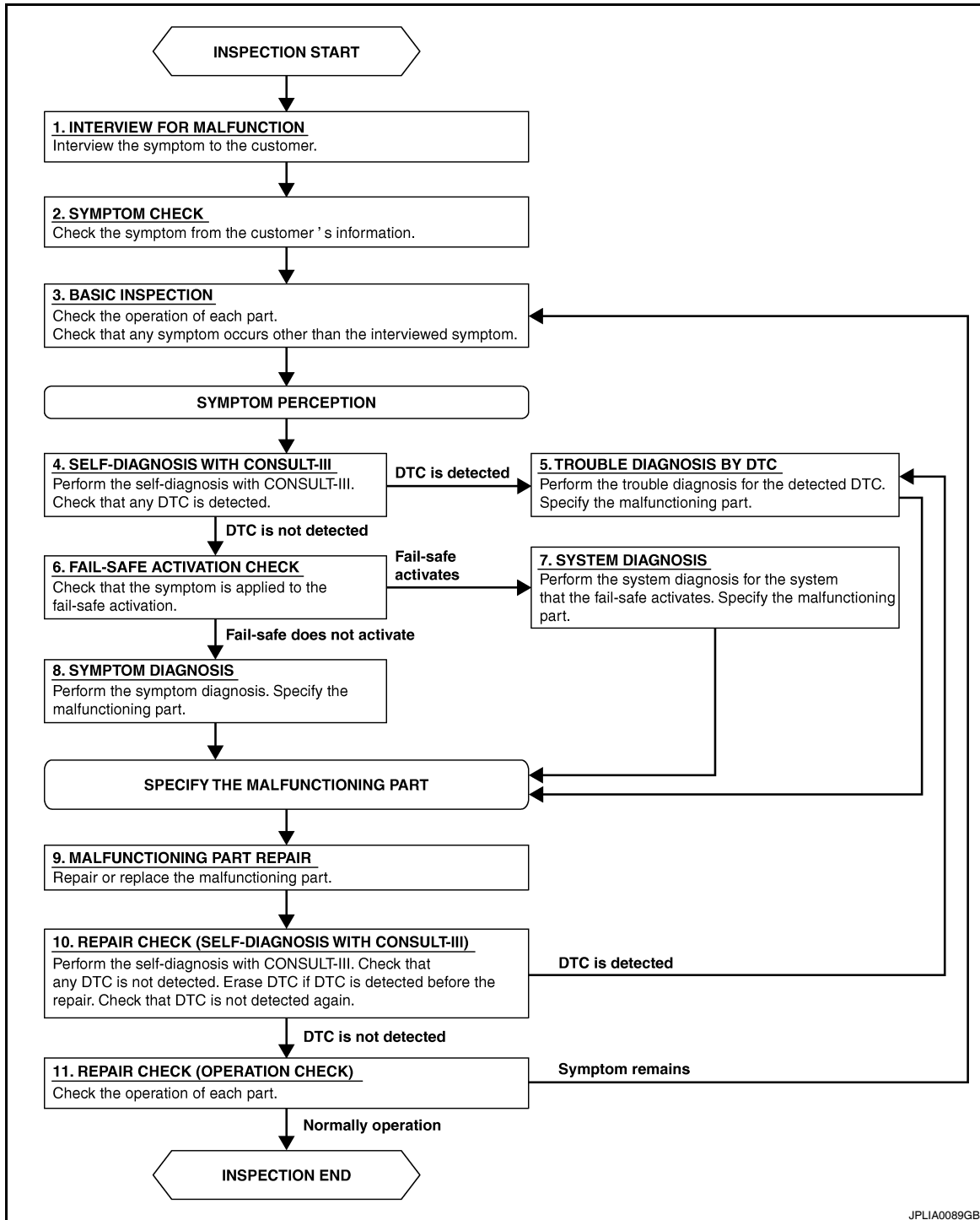

JPLIA0089GB

DETAILED FLOW

1. INTERVIEW FOR MALFUNCTION

Find out what the customer's concerns are.

DIAGNOSIS AND REPAIR WORKFLOW

[HALOGEN TYPE]

< BASIC INSPECTION >

>> GO TO 2.

2. SYMPTOM CHECK

Verify the symptom from the customer's information.

>> GO TO 3.

3. BASIC INSPECTION

Check the operation of each part. Check if any concerns occur other than those mentioned in the customer interview.

>> GO TO 4.

4. SELF-DIAGNOSIS WITH CONSULT-III

Perform the self diagnosis with CONSULT-III. Check if any DTC is detected.

Is any DTC detected?

YES >> GO TO 5.

NO >> GO TO 6.

5. TROUBLE DIAGNOSIS BY DTC

Perform the trouble diagnosis for the detected DTC. Specify the malfunctioning part.

>> GO TO 9.

6. FAIL-SAFE ACTIVATION CHECK

Determine if the customer's concern is related to fail-safe activation.

Does the fail-safe activate?

YES >> GO TO 7.

NO >> GO TO 8.

7. SYSTEM DIAGNOSIS

Perform the system diagnosis for the system in which the fail-safe activates. Specify the malfunctioning part.

>> GO TO 9.

8. SYMPTOM DIAGNOSIS

Perform the symptom diagnosis. Specify the malfunctioning part.

>> GO TO 9.

9. MALFUNCTION PART REPAIR

Repair or replace the malfunctioning part.

>> GO TO 10.

10. REPAIR CHECK (SELF-DIAGNOSIS WITH CONSULT-III)

Perform the self diagnosis with CONSULT-III. Verify that no DTCs are detected. Erase all DTCs which were detected prior to the repair. Perform the self diagnosis with CONSULT-III again. Verify that DTC is not detected again.

Is any DTC detected?

YES >> GO TO 5.

NO >> GO TO 11.

11. REPAIR CHECK (OPERATION CHECK)

Check the operation of each part.

A

B

C

D

E

F

G

H

I

J

K

EXL

M

N

O

P

DIAGNOSIS AND REPAIR WORKFLOW

< BASIC INSPECTION >

[HALOGEN TYPE]

Does it operate normally?

YES >> Inspection End.

NO >> GO TO 3.

FUNCTION DIAGNOSIS

HEADLAMP

System Diagram

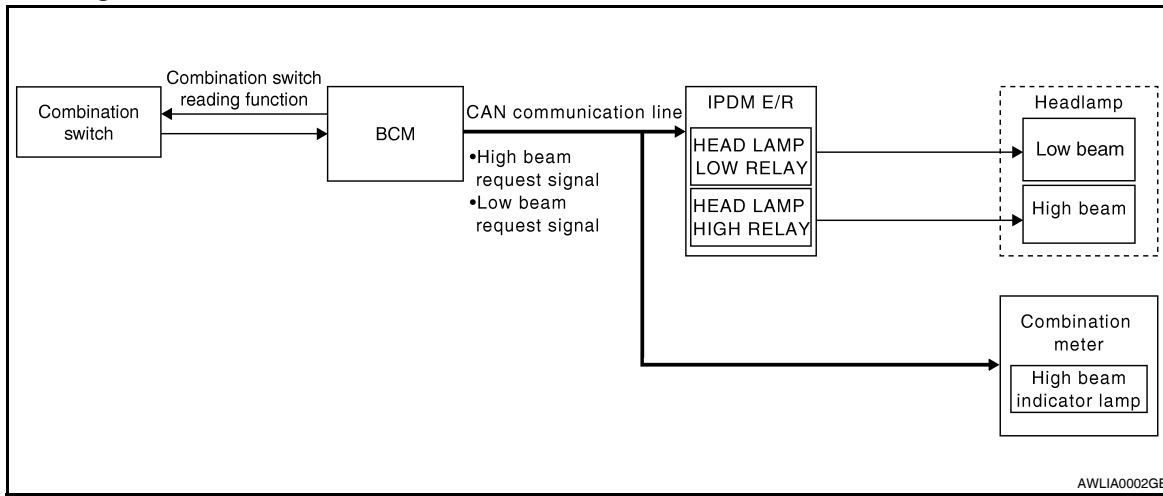

System Description

INFOID:000000005460931

Control of the headlamp system operation is dependent upon the position of the lighting switch (combination switch). When the lighting switch is placed in the 2nd position, the BCM (body control module) receives input requesting the headlamps and park lamps to illuminate. This input is communicated to the IPDM E/R (intelligent power distribution module engine room) across the CAN communication lines. The CPU (central processing unit) of the IPDM E/R controls the headlamp high and headlamp low relay coils. When energized, these relays direct power to the respective headlamps, which then illuminate.

Component Parts Location

INFOID:000000005460932

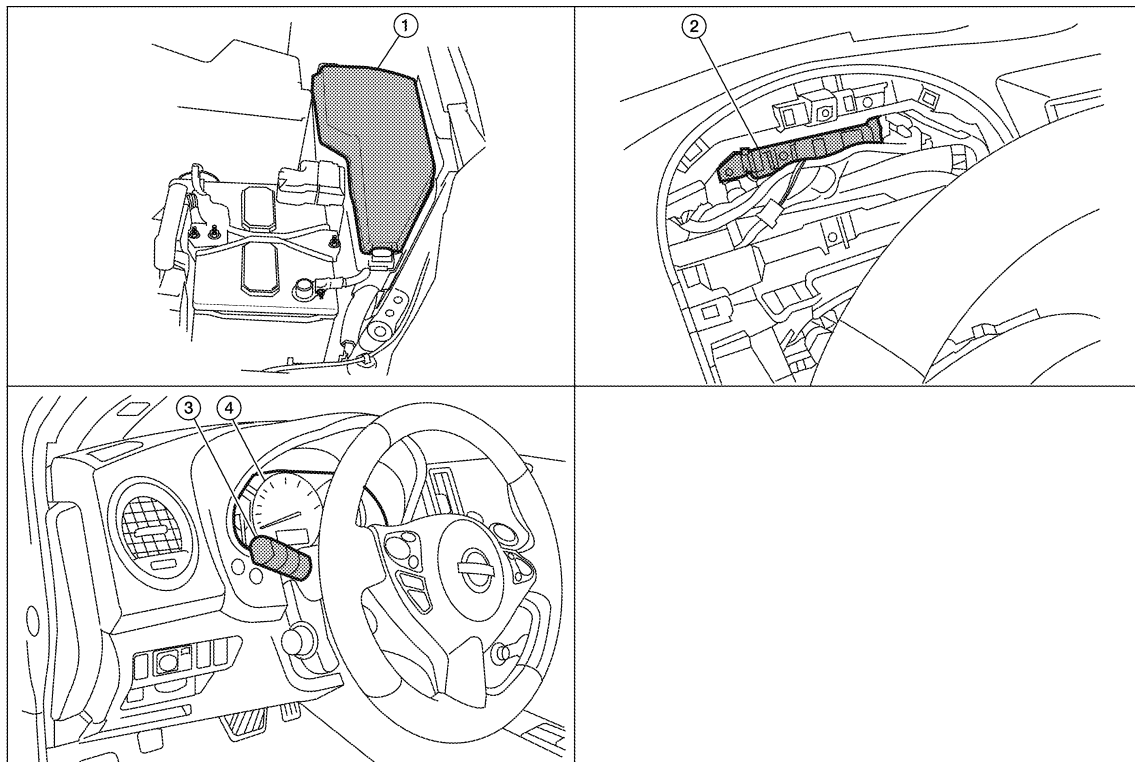

A
B
C
D
E
F
G
H
I
J
K
EXL
M
N
O
P

HEADLAMP

< FUNCTION DIAGNOSIS >

[HALOGEN TYPE]

1. IPDM E/R E17, E18, E200
2. BCM M16, M17, M18, M19 (view with combination meter removed)
3. Combination switch (lighting and turn signal switch) M28
4. Combination meter M24

Component Description

INFOID:000000005460933

LOW BEAM OPERATION

When the lighting switch is in 2ND position, the BCM receives input requesting the headlamps to illuminate. This input is communicated to the IPDM E/R across the CAN communication lines. The CPU of the IPDM E/R controls the headlamp low relay coil which supplies power to the low beam headlamps.

HIGH BEAM OPERATION/FLASH-TO-PASS OPERATION

With the lighting switch in the 2ND position and placed in HIGH position, the BCM receives input requesting the headlamp high beams to illuminate. The flash-to-pass feature can be used any time and also sends a signal to the BCM. This input is communicated to the IPDM E/R across the CAN communication lines. The CPU of the combination meter controls the ON/OFF status of the HIGH BEAM indicator. The CPU of the IPDM E/R controls the headlamp high relay coil which supplies power to the high beam headlamps.

The combination meter receives a high beam request signal (ON) through the CAN communication lines and turns the high beam indicator lamp ON.

EXTERIOR LAMP BATTERY SAVER CONTROL

With the lighting switch (combination switch) in the 2nd position and the ignition switch is turned from ON or ACC to OFF, the battery saver feature is activated.

Under this condition, the headlamps remain illuminated for 5 minutes unless the lighting switch position is changed. If the lighting switch position is changed, then the headlamps are turned off.

This setting can be changed by CONSULT-III. Refer to [EXL-199. "HEADLAMP : CONSULT-III Function \(BCM-HEAD LAMP\)".](#)

DAYTIME RUNNING LIGHT SYSTEM

< FUNCTION DIAGNOSIS >

[HALOGEN TYPE]

DAYTIME RUNNING LIGHT SYSTEM

System Diagram

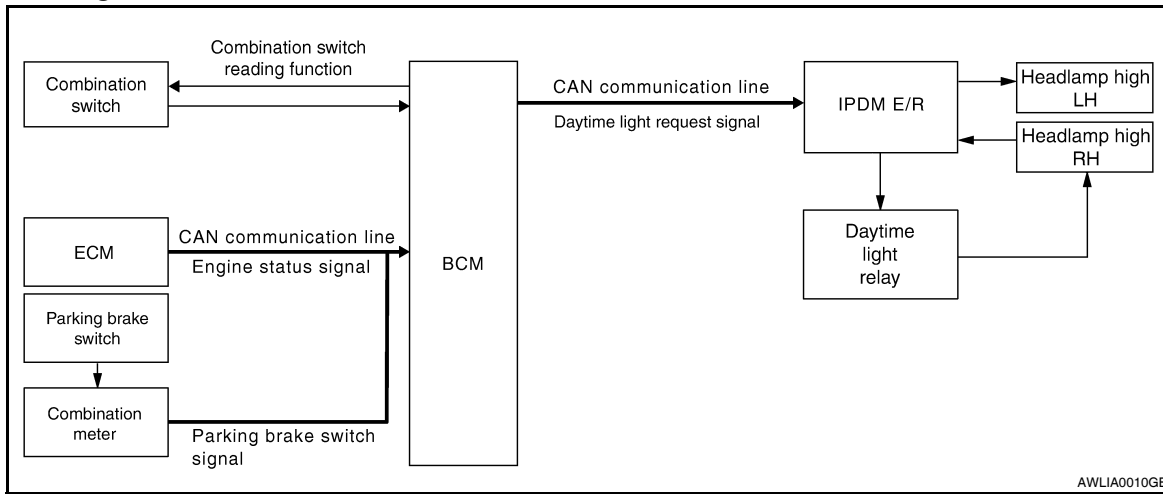

System Description

INFOID:000000005460935

The headlamp system for Canada vehicles is equipped with a daytime light relay that activates the high beam headlamps at approximately half illumination whenever the engine is running. If the parking brake is depressed before the engine is started, the daytime lights will not be illuminated. The daytime lights will illuminate once the parking brake is released. Thereafter, the daytime lights will continue to operate when the parking brake is depressed.

Component Parts Location

INFOID:000000005460936

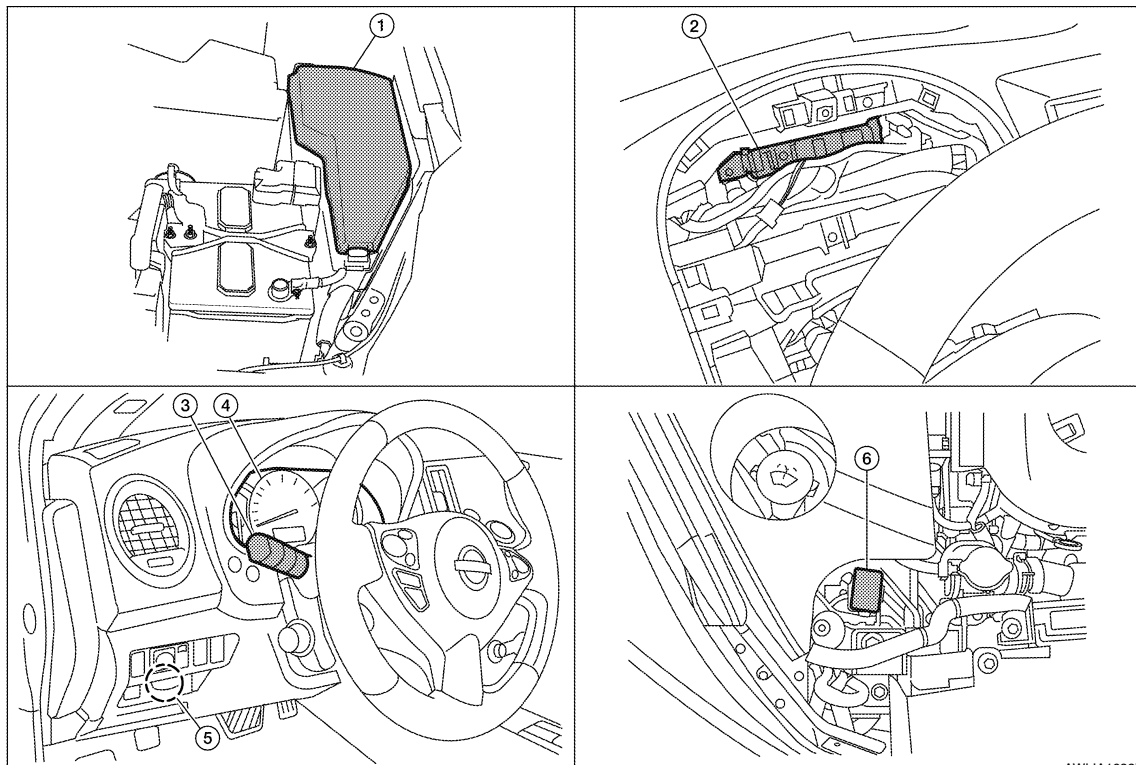

- | | | |
|----------------------------------|---|---|
| 1. IPDM E/R E17, E18, E200, E201 | 2. BCM M16, M17, M18, M19 (view with combination meter removed) | 3. Combination switch (lighting and turn signal switch) M28 |
| 4. Combination meter M24 | 5. Parking brake switch E35 | 6. Daytime light relay E228 |

DAYTIME RUNNING LIGHT SYSTEM

[HALOGEN TYPE]

< FUNCTION DIAGNOSIS >

INFOID:000000005460937

Component Description

After starting the engine with the parking brake released and the lighting switch in the OFF or 1ST position, the headlamp high beam automatically turns on. With the lighting switch in the 2nd position or with autolamps ON, the headlamps function the same as conventional light systems.

OPERATION

The BCM monitors inputs from the parking brake switch and the combination switch to determine when to activate the daytime light system. The BCM sends a daytime light request to the IPDM E/R via the CAN communication lines. The IPDM E/R grounds the daytime light relay which in turn, provides power to the ground side of the RH high beam lamp. Power flows backward through the RH high beam lamp to the IPDM E/R, through the high beam fuses, through the LH high beam lamp circuit to the LH high beam lamp and on to ground. The high beam lamps are wired in series which causes them to illuminate at a reduced intensity.

Engine		With engine stopped									With engine running								
Lighting switch		OFF			1ST			2ND			OFF			1ST			2ND		
		Hi	Lo	P	Hi	Lo	P	Hi	Lo	P	Hi	Lo	P	Hi	Lo	P	Hi	Lo	P
Headlamp	High beam	-	-	-	-	-	×	×	-	×	●*	●*	×	●*	●*	×	×	-	×
	Low beam	-	-	-	-	-	×	×	×	×	-	-	×	-	-	×	×	×	×
Tail lamp		-	-	-	×	×	×	×	×	×	-	-	-	×	×	×	×	×	×
License and instrument illumination lamp		-	-	-	×	×	×	×	×	×	-	-	-	×	×	×	×	×	×

- Hi: "HIGH BEAM" position
- Lo: "LOW BEAM" position
- P: "FLASH TO PASS" position
- ×: Lamp "ON"
- -: Lamp "OFF"
- ●: Lamp dims. (Added functions)
- *: When starting the engine with the parking brake released, the daytime lights will operate.
When starting the engine with the parking brake depressed, the daytime lights will not operate.

AUTO LIGHT SYSTEM

System Diagram

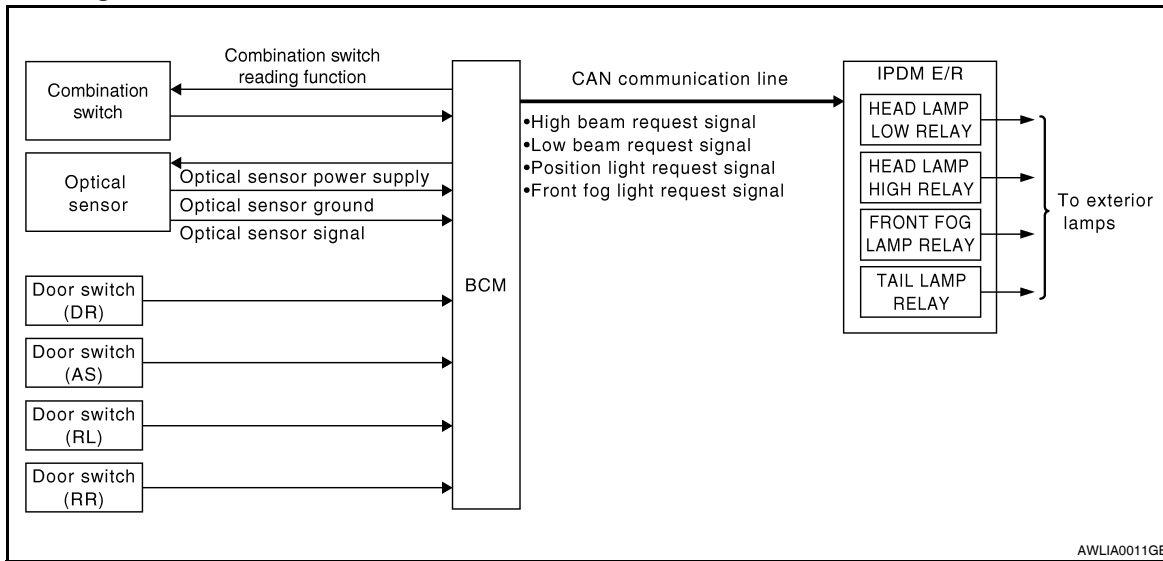

System Description

INFOID:000000005531138

- BCM (Body Control Module) controls auto light operation according to signals from optical sensor, lighting switch and ignition switch.
- IPDM E/R (Intelligent Power Distribution Module Engine Room) operates parking, license plate, tail, front fog lamps and headlamps according to CAN communication signals from BCM.
- Optical sensor detects ambient brightness of 800 to 2,500 lux, converts light (lux) to voltage, and then sends the optical sensor signal to BCM.

OUTLINE

The auto light control system has an optical sensor that detects outside brightness. When the lighting switch is in AUTO position, it automatically turns ON/OFF the parking, license plate, tail, front fog lamps and headlamps in accordance with the ambient light. Sensitivity can be adjusted in four steps. For the details of the setting, refer to [EXL-199, "HEADLAMP : CONSULT-III Function \(BCM-HEAD LAMP\)"](#).

A
B
C
D
E
F
G
H
I
J
K

EXL

AUTO LIGHT SYSTEM

< FUNCTION DIAGNOSIS >

[HALOGEN TYPE]

Component Parts Location

INFOID:000000005531139

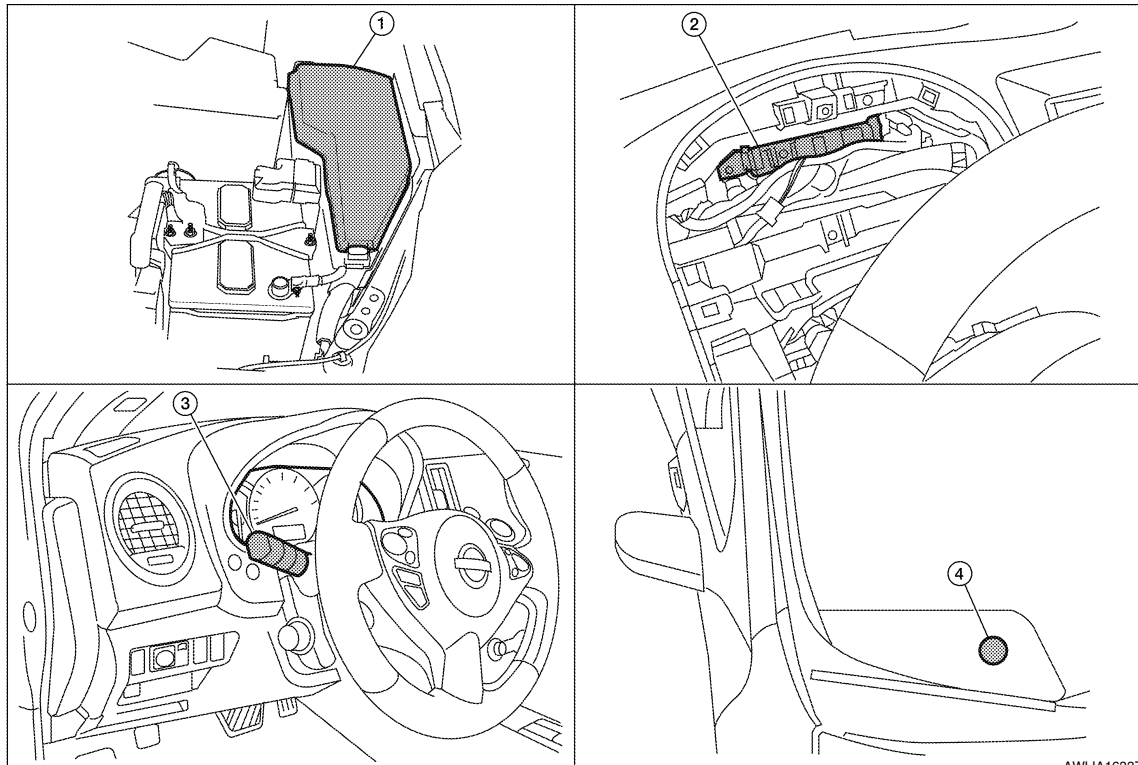

AWLIA1693ZZ

1. IPDM E/R E17, E18, E20
2. BCM M16, M17, M18, M19, M21 (view with combination meter removed)
3. Combination switch (lighting and turn signal switch) M28
4. Optical sensor M66

Component Description

INFOID:000000005531140

AUTO LIGHT OPERATION

Applicable lamps

- Low beam headlamp
- Parking, license plate and tail lamps
- High beam headlamp (with the lighting switch in HIGH BEAM position)
- Front fog lamp (with the lighting switch in front fog lamp ON position)

When the lighting switch is in AUTO position with the ignition switch in ON position, BCM detects the AUTO LIGHT (ON) by BCM combination switch reading function. BCM turns automatically ON/OFF the applicable lamps according to ambient brightness.

NOTE:

Timing for when lamps turn ON/OFF can be changed by the function setting of CONSULT-III. Refer to [EXL-199, "HEADLAMP : CONSULT-III Function \(BCM-HEAD LAMP\)"](#).

FRONT FOG LAMP

< FUNCTION DIAGNOSIS >

[HALOGEN TYPE]

FRONT FOG LAMP

System Diagram

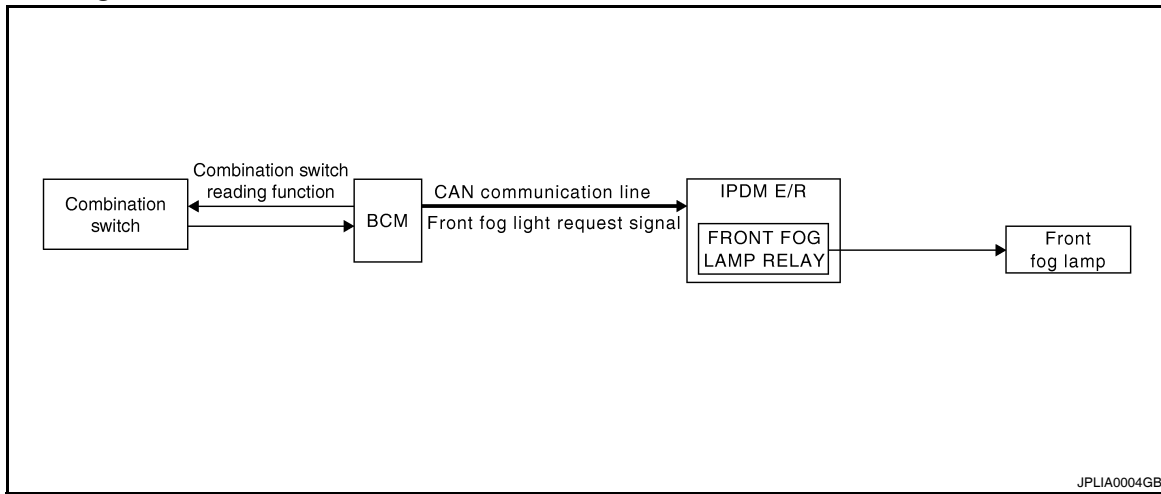

System Description

INFOID:000000005531142

- BCM (Body Control Module) controls front fog lamp operation.
- IPDM E/R (Intelligent Power Distribution Module Engine Room) operates front fog lamp according to CAN communication signals from BCM.
- Combination meter operates front fog lamp indicator according to inputs via the CAN communication lines.

Component Parts Location

INFOID:000000005531143

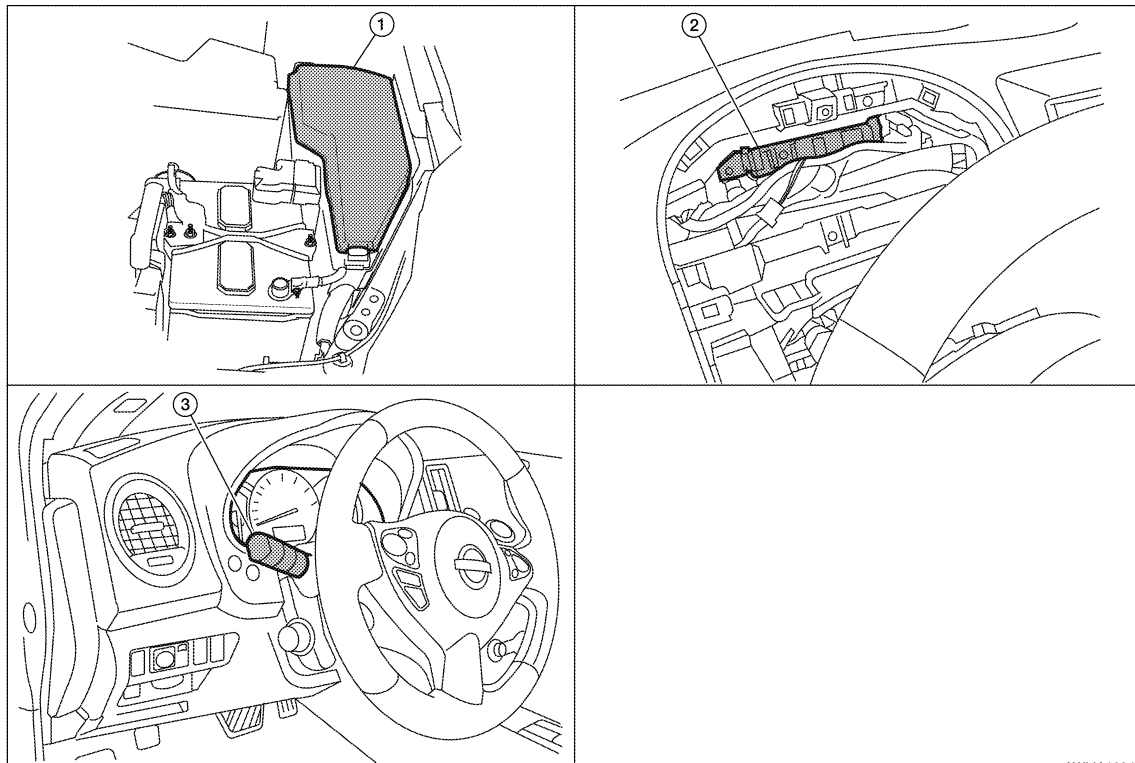

FRONT FOG LAMP

< FUNCTION DIAGNOSIS >

[HALOGEN TYPE]

Component Description

INFOID:00000000531144

FRONT FOG LAMP OPERATION

When the lighting switch is in front fog lamp ON position and also in 1ST or 2ND position or AUTO position (headlamp is ON), the BCM detects FR FOG ON and the HEAD LAMP1, 2 ON or the AUTO LIGHT ON. The BCM sends a front fog lamp request ON signal through the CAN communication lines to the IPDM E/R. The IPDM E/R then turns ON the front fog lamp relay sending power to the front fog lamps.

The combination meter also receives a front fog lamp request ON signal through the CAN communication lines at which time it turns the front fog indicator ON.

TURN SIGNAL AND HAZARD WARNING LAMPS

< FUNCTION DIAGNOSIS >

[HALOGEN TYPE]

TURN SIGNAL AND HAZARD WARNING LAMPS

System Diagram

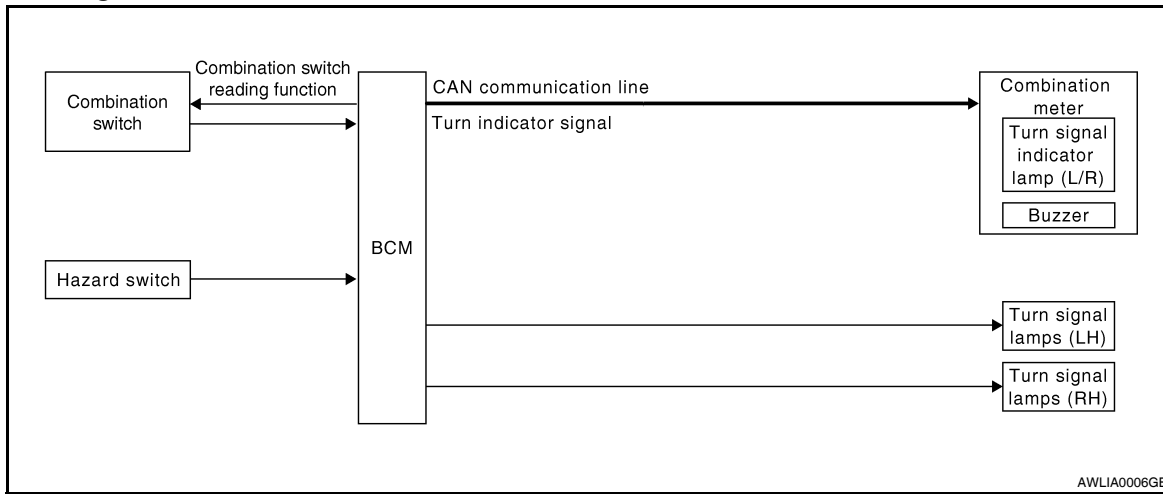

System Description

INFOID:000000005531146

- BCM (Body Control Module) controls turn signal lamp (RH and LH) and hazard warning lamp operation.
- Combination meter operates turn signal indicator (RH and LH) according to CAN communication signals from BCM.

Component Parts Location

INFOID:000000005531147

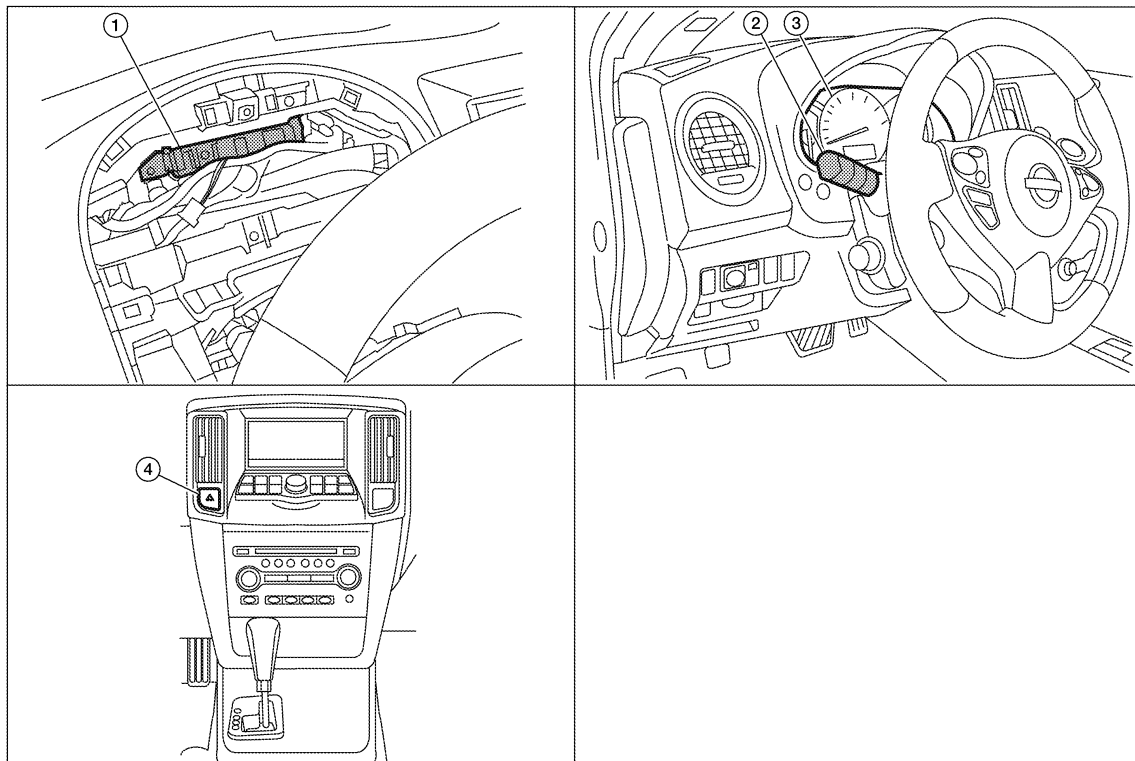

1. BCM M16, M17, M18, M19 (view with combination meter removed)
2. Combination switch (lighting and turn signal switch) M28
3. Combination meter M24
4. Hazard switch M54

TURN SIGNAL AND HAZARD WARNING LAMPS

< FUNCTION DIAGNOSIS >

[HALOGEN TYPE]

Component Description

INFOID:00000000531148

TURN SIGNAL OPERATION

When the turn signal switch is in LH or RH position with the ignition switch in ON position, the BCM detects the TURN RH or TURN LH ON request. The BCM outputs the flasher output signal to the respective turn signal lamp. The BCM sends a turn signal indicator ON request through the CAN communication lines to the combination meter. The combination meter then activates the appropriate turn signal indicator and audible buzzer.

HAZARD LAMP OPERATION

When the hazard switch is in ON position, the BCM detects the hazard switch signal ON. The BCM outputs the flasher output signal (right and left). The BCM sends a hazard indicator signal ON request through the CAN communication lines to the combination meter. The combination meter then activates the hazard indicator and audible buzzer.

REMOTE KEYLESS ENTRY OPERATION

The remote keyless entry receiver transmits Intelligent Key signal to BCM, then BCM controls hazard lamps. Refer to [SEC-21, "System Description"](#).

PARKING, LICENSE PLATE AND TAIL LAMPS

< FUNCTION DIAGNOSIS >

[HALOGEN TYPE]

PARKING, LICENSE PLATE AND TAIL LAMPS

System Diagram

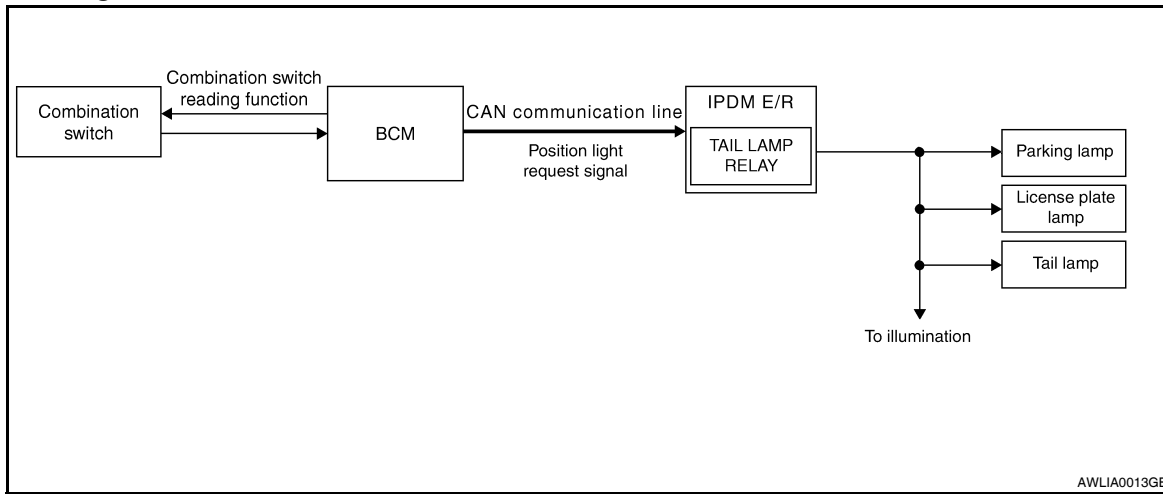

System Description

- BCM (Body Control Module) controls parking, license plate and tail lamps operation.
- IPDM E/R (Intelligent Power Distribution Module Engine Room) operates parking, license plate and tail lamps according to CAN communication signals from BCM.

Component Parts Location

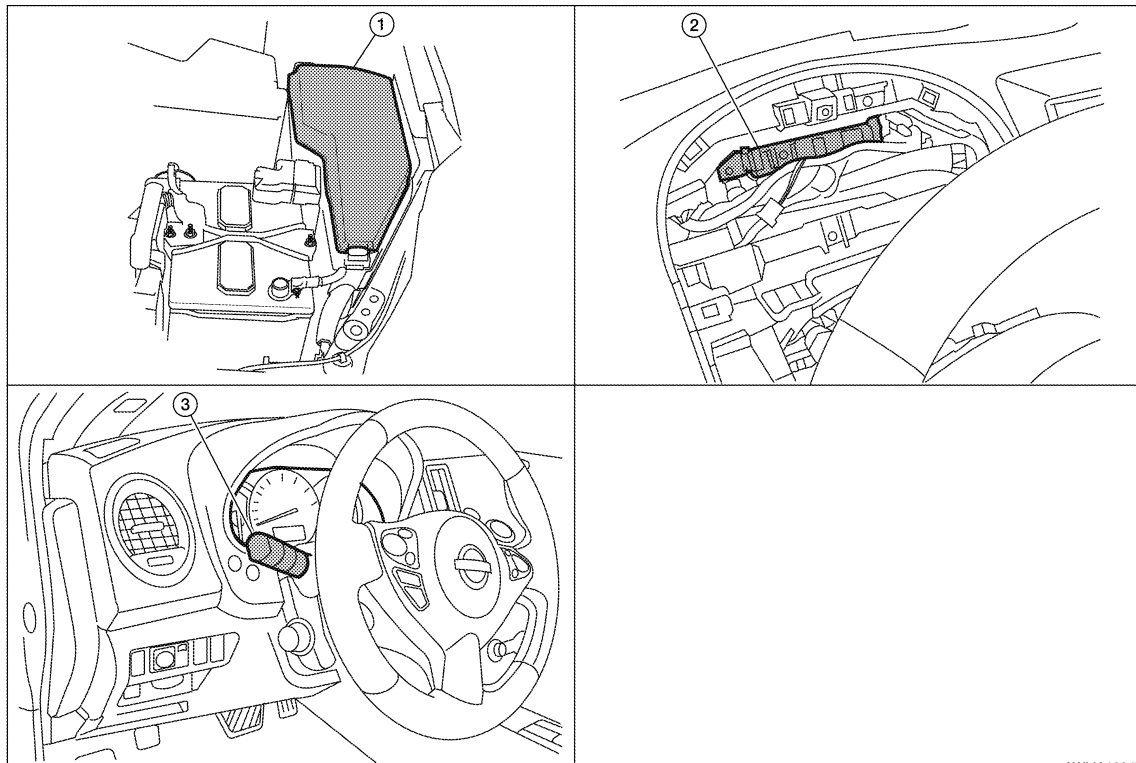

1. IPDM E/R E17, E18, E20

2. BCM M16, M17, M18, M19 (view with combination meter removed)

3. Combination switch (lighting and turn signal switch) M28

PARKING, LICENSE PLATE AND TAIL LAMPS

< FUNCTION DIAGNOSIS >

[HALOGEN TYPE]

Component Description

INFOID:00000000531152

PARKING, LICENSE PLATE AND TAIL LAMPS OPERATION

When the lighting switch is in 1ST position, BCM detects the LIGHTING SWITCH 1ST POSITION ON. The BCM sends a parking light ON request through the CAN communication lines to the IPDM E/R. The IPDM E/R then activates the tail lamp relay which sends power to the parking and instrument illumination circuits.

EXTERIOR LAMP BATTERY SAVER CONTROL

With the lighting switch (combination switch) in the 2nd position and the ignition switch is turned from ON or ACC to OFF, the battery saver feature is activated.

Under this condition, the headlamps remain illuminated for 5 minutes unless the lighting switch position is changed. If the lighting switch position is changed, then the headlamps are turned off.

This setting can be changed by CONSULT-III. Refer to [EXL-199. "HEADLAMP : CONSULT-III Function \(BCM-HEAD LAMP\)"](#).

COMBINATION SWITCH READING SYSTEM

< FUNCTION DIAGNOSIS >

[HALOGEN TYPE]

COMBINATION SWITCH READING SYSTEM

System Diagram

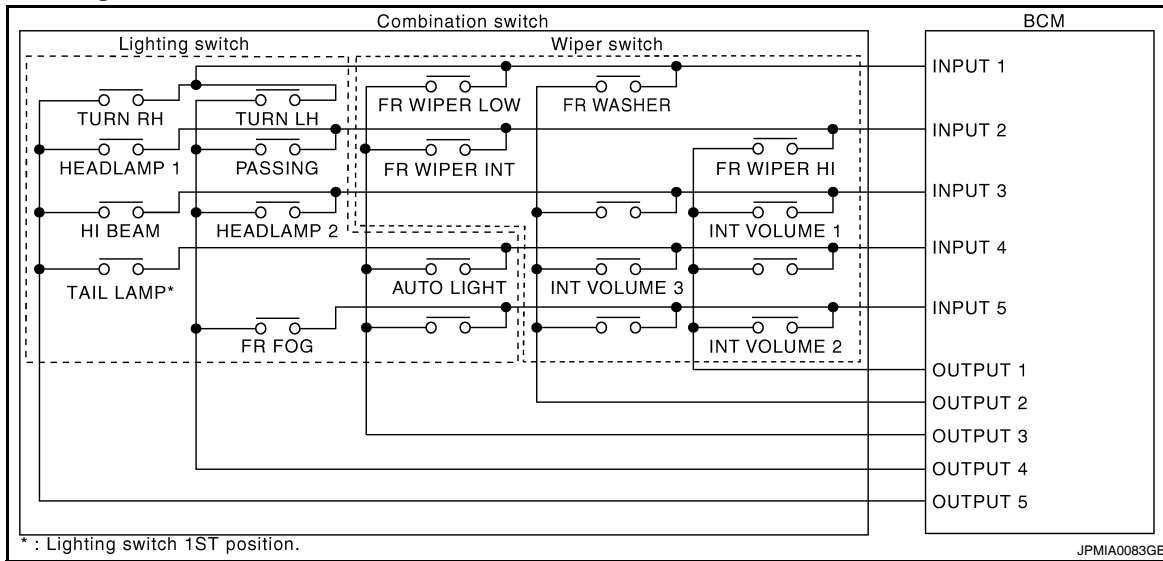

System Description

INFOID:000000005530157

OUTLINE

- BCM reads the status of the combination switch (light, turn signal, wiper and washer) and recognizes the status of each switch.
- BCM is a combination of 5 output terminals (OUTPUT 1 - 5) and 5 input terminals (INPUT 1 - 5). It reads a maximum of 20 switch status.

COMBINATION SWITCH MATRIX

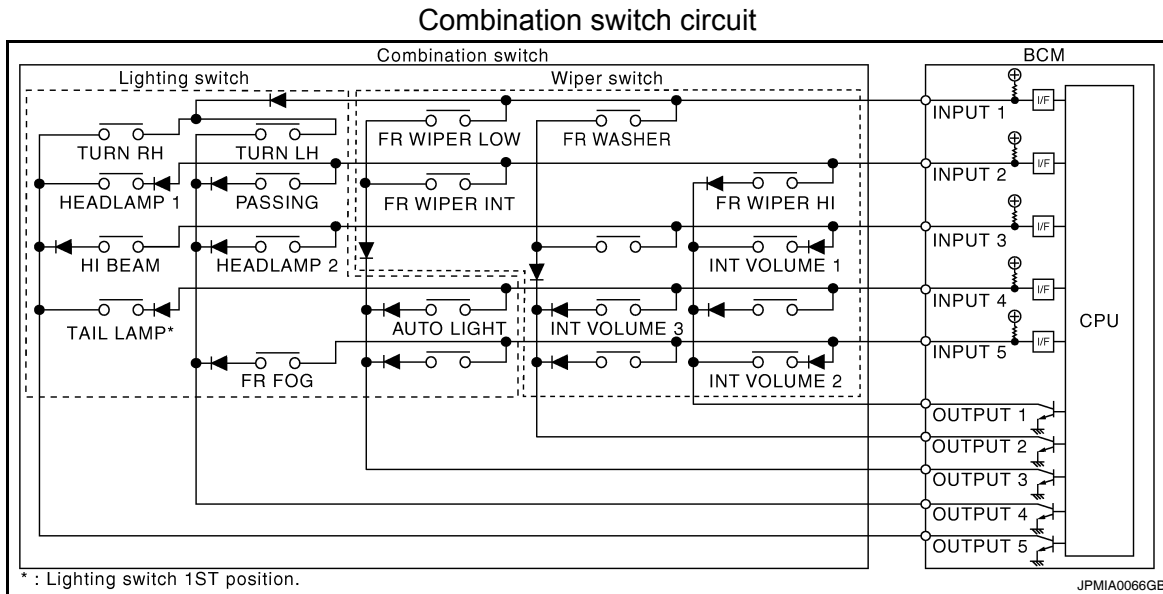

Combination switch INPUT-OUTPUT system list

System	OUTPUT 1	OUTPUT 2	OUTPUT 3	OUTPUT 4	OUTPUT 5
INPUT 1	—	FR WASHER	FR WIPER LOW	TURN LH	TURN RH
INPUT 2	FR WIPER HI	—	FR WIPER INT	PASSING	HEADLAMP 1
INPUT 3	INT VOLUME 1	—	—	HEADLAMP 2	HI BEAM

COMBINATION SWITCH READING SYSTEM

< FUNCTION DIAGNOSIS >

[HALOGEN TYPE]

System	OUTPUT 1	OUTPUT 2	OUTPUT 3	OUTPUT 4	OUTPUT 5
INPUT 4	—	INT VOLUME 3	AUTO LIGHT	—	TAIL LAMP
INPUT 5	INT VOLUME 2	—	—	FR FOG	—

NOTE:

Headlamp has a dual system switch.

COMBINATION SWITCH READING FUNCTION

Description

- BCM reads the status of the combination switch at 10ms interval normally.

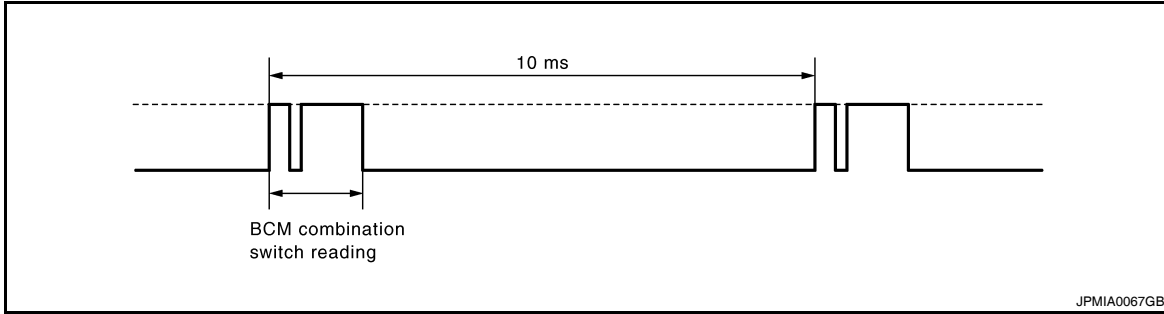

NOTE:

BCM reads the status of the combination switch at 60ms interval when BCM is controlled at low power consumption mode.

- BCM operates as follows and judges the status of the combination switch.
- INPUT 1 - 5 outputs the voltage waveforms of 5 systems simultaneously.
- It operates the transistor on OUTPUT side in the following order: OUTPUT 5 → 4 → 3 → 2 → 1.
- The voltage waveform of INPUT corresponding to the formed circuit changes according to the operation of the transistor on OUTPUT side if any (1 or more) switches are ON.
- It reads this change of the voltage as the status signal of the combination switch.

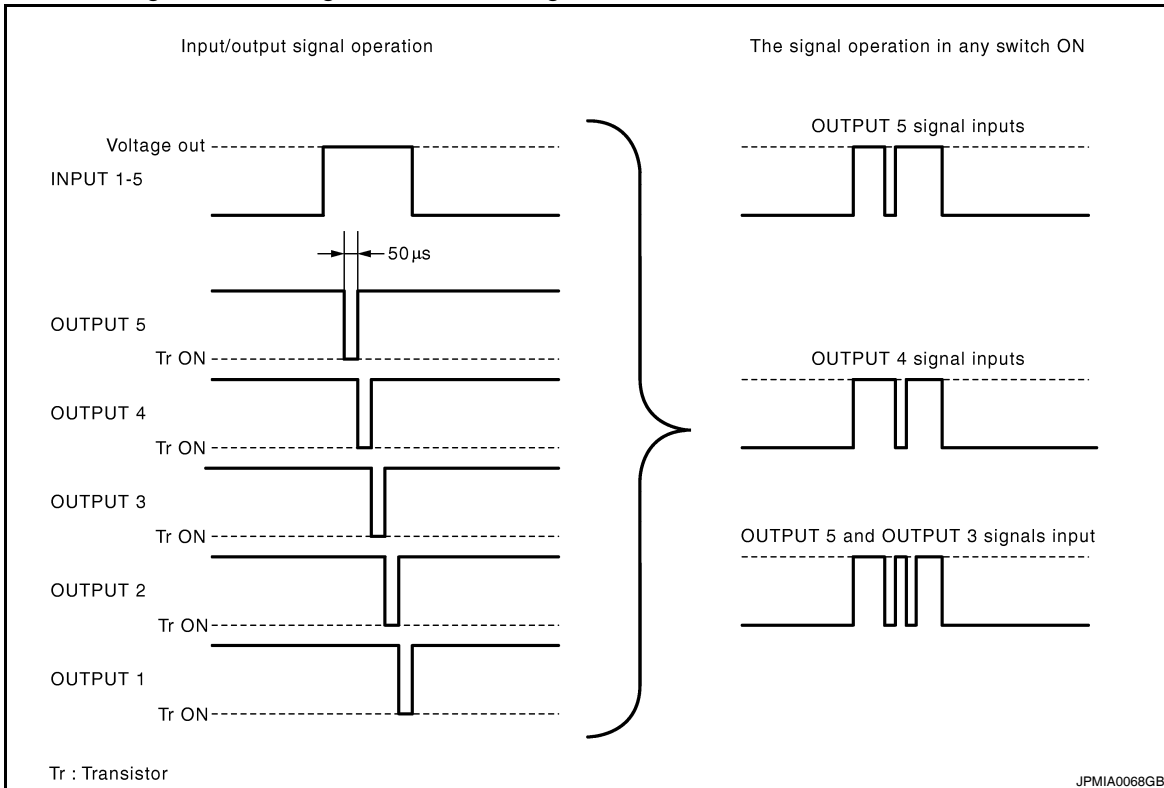

Operation Example

In the following operation example, the combination of the status signals of the combination switch is replaced as follows: INPUT 1 - 5 to "1 - 5" and OUTPUT 1 - 5 to "A - E".

Example 1: When a switch (TURN RH switch) is turned ON

COMBINATION SWITCH READING SYSTEM

[HALOGEN TYPE]

< FUNCTION DIAGNOSIS >

- The circuit between INPUT 1 and OUTPUT 5 is formed when the TURN RH switch is turned ON.

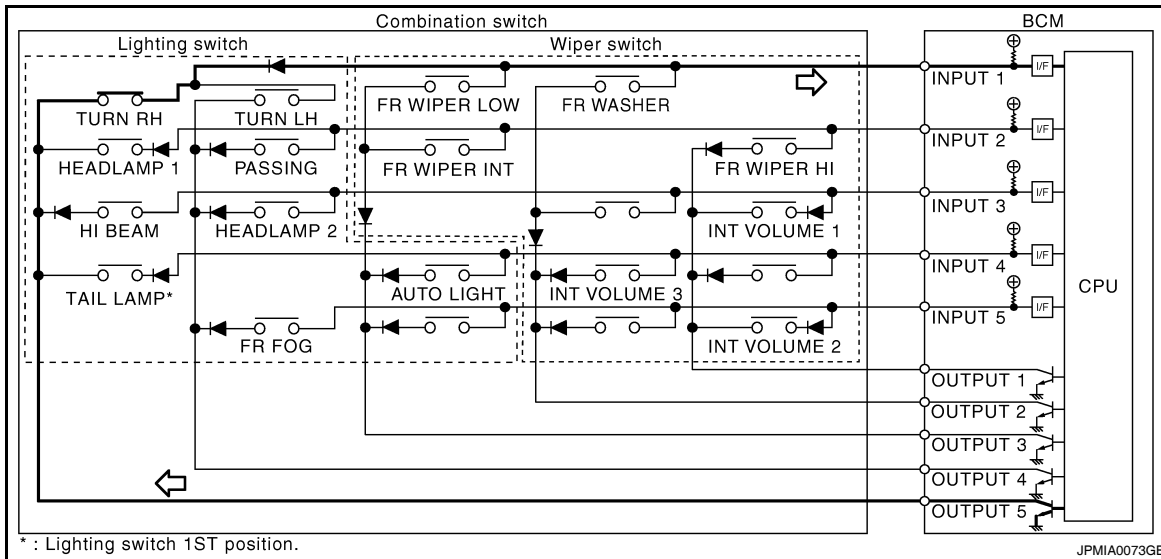

- BCM detects the combination switch status signal "1E" when the signal of OUTPUT 5 is input to INPUT 1.
- BCM judges that the TURN RH switch is ON when the signal "1E" is detected.
- Example 2: When some switches (TURN RH switch, FR WIPER LOW switch) are turned ON

Example 2: When some switches (turn RH switch, front wiper LO switch) are turned ON

- The circuits between INPUT 1 and OUTPUT 5 and between INPUT 1 and OUTPUT 3 are formed when the TURN RH switch and FR WIPER LOW switch are turned ON.

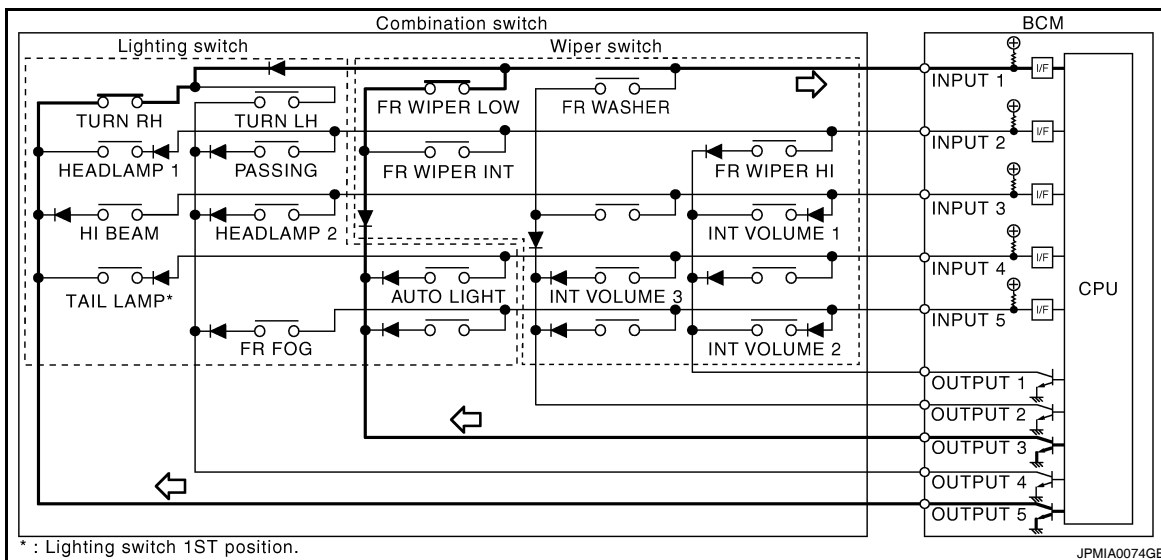

- BCM detects the combination switch status signal "1CE" when the signals of OUTPUT 3 and OUTPUT 5 are input to INPUT 1.
- BCM judges that the TURN RH switch and FR WIPER LOW switch are ON when the signal "1CE" is detected.

WIPER INTERMITTENT DIAL POSITION SETTING (FRONT WIPER INTERMITTENT OPERATION)

BCM judges the wiper intermittent dial 1 - 7 by the status of INT VOLUME 1, 2, and 3 switches.

COMBINATION SWITCH READING SYSTEM

< FUNCTION DIAGNOSIS >

[HALOGEN TYPE]

Wiper intermittent dial position	Intermittent operation delay interval	INT VOLUME switch ON/OFF status		
		INT VOLUME 1 switch	INT VOLUME 2 switch	INT VOLUME 3 switch
1	Short ↑	ON	ON	ON
2		ON	ON	OFF
3		ON	OFF	OFF
4		OFF	OFF	OFF
5	↓ Long	OFF	OFF	ON
6		OFF	ON	ON
7		OFF	ON	OFF

DIAGNOSIS SYSTEM (BCM)

< FUNCTION DIAGNOSIS >

[HALOGEN TYPE]

DIAGNOSIS SYSTEM (BCM)

HEADLAMP

HEADLAMP : CONSULT-III Function (BCM-HEAD LAMP)

INFOID:000000005530158

WORK SUPPORT

Service item	Setting item	Setting	
CUSTOM A/LIGHT SETTING	MODE 1*	Normal	
	MODE 2	More sensitive setting than normal setting (Turns ON earlier than normal operation.)	
	MODE 3	More sensitive setting than MODE 2 (Turns ON earlier than MODE 2.)	
	MODE 4	Less sensitive setting than normal setting (Turns ON later than normal operation.)	
BATTERY SAVER SET	ON*	With the exterior lamp battery saver function	
	OFF	Without the exterior lamp battery saver function	
ILL DELAY SET	MODE 1	45 sec.	Sets delay timer function timer operation time (All doors closed)
	MODE 2	Without the function	
	MODE 3	30 sec.	
	MODE 4	60 sec.	
	MODE 5	90 sec.	
	MODE 6	120 sec.	
	MODE 7	150 sec.	
	MODE 8	180 sec.	

* : Initial setting

DATA MONITOR

Monitor item [Unit]	Description
PUSH SW [ON/OFF]	The switch status input from push-button ignition switch
ENGINE STATE [STOP/STALL/CRANK/RUN]	The engine status received from ECM with CAN communication
VEH SPEED 1 [km/h]	The value of the vehicle speed received from combination meter with CAN communication
KEY SW-SLOT [ON/OFF]	Key switch status input from key slot

DIAGNOSIS SYSTEM (BCM)

[HALOGEN TYPE]

< FUNCTION DIAGNOSIS >

Monitor item [Unit]	Description
TURN SIGNAL R [ON/OFF]	Each switch status that BCM judges from the combination switch reading function
TURN SIGNAL L [ON/OFF]	
TAIL LAMP SW [ON/OFF]	
HI BEAM SW [ON/OFF]	
HEAD LAMP SW1 [ON/OFF]	
HEAD LAMP SW2 [ON/OFF]	
PASSING SW [ON/OFF]	
AUTO LIGHT SW [ON/OFF]	
FR FOG SW [ON/OFF]	
DOOR SW-DR [ON/OFF]	The switch status input from front door switch LH
DOOR SW-AS [ON/OFF]	The switch status input from front door switch RH
DOOR SW-RR [ON/OFF]	The switch status input from rear door switch RH
DOOR SW-RL [ON/OFF]	The switch status input from rear door switch LH
OPTICAL SENSOR [V]	The value of exterior brightness voltage input from the optical sensor

ACTIVE TEST

Test item	Operation	Description
TAIL LAMP	ON	Transmits the Position light request signal to IPDM E/R with CAN communication to turn the tail lamp ON.
	OFF	Stops the tail lamp request signal transmission.
HEAD LAMP	HI	Transmits the high beam request signal with CAN communication to turn the headlamp (HI)
	LO	Transmits the low beam request signal with CAN communication to turn the headlamp (LO).
	OFF	Stops the high & low beam request signal transmission.
FR FOG LAMP	ON	Transmits the front fog lights request signal to IPDM E/R with CAN communication to turn the front fog lamp ON.
	OFF	Stops the front fog lights request signal transmission.

FLASHER

FLASHER : CONSULT-III Function (BCM-FLASHER)

INFOID:000000005530159

WORK SUPPORT

DIAGNOSIS SYSTEM (BCM)

< FUNCTION DIAGNOSIS >

[HALOGEN TYPE]

Service item	Setting item	Setting	
HAZARD ANSWER BACK	Lock Only*	Activated when locking.	Sets the hazard warning lamp answer back activation when the door is lock/unlock with the request switch or the key fob.
	Unlock Only	Activated when unlocking.	
	Lock/unlock	Activated when locking/unlocking	
	OFF	Not activated	

* : Initial setting

DATA MONITOR

Monitor item [Unit]	Description
REQ SW-DR [ON/OFF]	The switch status input from the request switch (driver side)
REQ SW-AS [ON/OFF]	The switch status input from the request switch (passenger side)
PUSH SW [ON/OFF]	The switch status input from the push-button ignition switch
TURN SIGNAL R [ON/OFF]	Each switch condition that BCM judges from the combination switch reading function
TURN SIGNAL L [ON/OFF]	
HAZARD SW [ON/OFF]	The switch status input from the hazard warning switch
RKE-LOCK [ON/OFF]	The lock signal status received from the keyless receiver
RKE-UNLOCK [ON/OFF]	The unlock signal status received from the keyless receiver
RKE-PANIC [ON/OFF]	The panic alarm signal status received from the keyless receiver

ACTIVE TEST

Test item	Operation	Description
FLASHER	RH	Blinks right turn signal lamp.
	LH	Blinks left turn signal lamp.
	OFF	Turns turn signal lamps (right and left) OFF.

COMB SW

COMB SW : CONSULT-III Function (BCM-COMB SW)

INFOID:000000005530160

DATA MONITOR

Monitor item [UNIT]	Description
FR WIPER HI [OFF/ON]	Displays the status of the FR WIPER HI switch in combination switch judged by BCM with the combination switch reading function.
FR WIPER LOW [OFF/ON]	Displays the status of the FR WIPER LOW switch in combination switch judged by BCM with the combination switch reading function.
FR WASHER SW [OFF/ON]	Displays the status of the FR WASHER switch in combination switch judged by BCM with the combination switch reading function.
FR WIPER INT [OFF/ON]	Displays the status of the FR WIPER INT switch in combination switch judged by BCM with the combination switch reading function.

DIAGNOSIS SYSTEM (BCM)

[HALOGEN TYPE]

< FUNCTION DIAGNOSIS >

Monitor item [UNIT]	Description
FR WIPER STOP [OFF/ON]	Displays the status of the front wiper stop position signal received from IPDM E/R via CAN communication.
INT VOLUME [1 - 7]	Displays the status of wiper intermittent dial position judged by BCM with the combination switch reading function
TURN SIGNAL R [OFF/ON]	Displays the status of theTURN RH switch in combination switch judged by BCM with the combination switch reading function.
TURN SIGNAL L [OFF/ON]	Displays the status of theTURN LH switch in combination switch judged by BCM with the combination switch reading function.
TAIL LAMP SW [OFF/ON]	Displays the status of the TAIL LAMP switch in combination switch judged by BCM with the combination switch reading function.
HI BEAM SW [OFF/ON]	Displays the status of the HI BEAM switch in combination switch judged by BCM with the combination switch reading function.
HEAD LAMP SW 1 [OFF/ON]	Displays the status of the HEADLAMP 1 switch in combination switch judged by BCM with the combination switch reading function.
HEAD LAMP SW 2 [OFF/ON]	Displays the status of the HEADLAMP 2 switch in combination switch judged by BCM with the combination switch reading function.
PASSING SW [OFF/ON]	Displays the status of the PASSING switch in combination switch judged by BCM with the combination switch reading function.
AUTO LIGHT SW [OFF/ON]	Displays the status of the AUTO LIGHT switch in combination switch judged by BCM with the combination switch reading function.
FR FOG SW [OFF/ON]	Displays the status of the FR FOG switch in combination switch judged by BCM with the combination switch reading function.

DIAGNOSIS SYSTEM (IPDM E/R)

Diagnosis Description

INFOID:000000005530258

AUTO ACTIVE TEST

Description

In auto active test mode, the IPDM E/R sends a drive signal to the following systems to check their operation.

- Oil pressure warning lamp
- Front wiper (LO, HI)
- Parking lamps
- License plate lamps
- Tail lamps
- Front fog lamps (if equipped)
- Headlamps (LO, HI)
- A/C compressor (magnet clutch)
- Cooling fans

Operation Procedure

1. Close the hood and lift the wiper arms from the windshield. (Prevent windshield damage due to wiper operation)
NOTE:
 When auto active test is performed with hood opened, sprinkle water on windshield beforehand.
2. Turn ignition switch OFF.
3. Turn the ignition switch ON, and within 20 seconds, press the front door switch LH 10 times. Then turn the ignition switch OFF.
CAUTION:
Close front door RH.
4. Turn the ignition switch ON within 10 seconds. After that the horn sounds once and the auto active test starts.
5. The oil pressure warning lamp starts blinking when the auto active test starts.
6. After a series of the following operations is repeated 3 times, auto active test is completed.

NOTE:

When auto active test mode has to be cancelled halfway through test, turn ignition switch OFF.

CAUTION:

- **If auto active test mode cannot be actuated, check door switch system. Refer to [DLK-68](#), "[Component Function Check](#)".**
- **Do not start the engine.**

Inspection in Auto Active Test Mode

When auto active test mode is actuated, the following 6 steps are repeated 3 times.

Operation sequence	Inspection Location	Operation
1	Oil pressure warning lamp	Blinks continuously during operation of auto active test
2	Front wiper	LO for 5 seconds → HI for 5 seconds
3	<ul style="list-style-type: none"> • Parking lamps • License plate lamps • Tail lamps • Front fog lamps (if equipped) 	10 seconds
4	Headlamps	LO ↔ HI 5 times
5	A/C compressor (magnet clutch)	ON ↔ OFF 5 times
6*	Cooling fans	MID for 5 seconds → HI for 5 seconds

*: Outputs duty ratio of 50% for 5 seconds → duty ratio of 100% for 5 seconds on the cooling fan control module.

DIAGNOSIS SYSTEM (IPDM E/R)

[HALOGEN TYPE]

< FUNCTION DIAGNOSIS >

Concept of auto active test

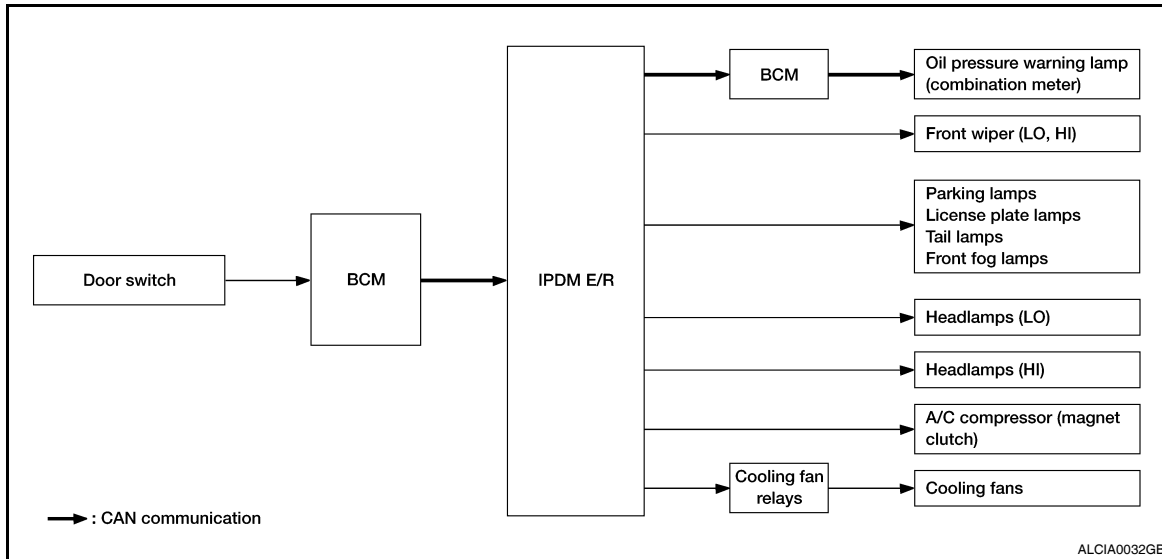

- IPDM E/R starts the auto active test with the door switch signals transmitted by BCM via CAN communication. Therefore, the CAN communication line between IPDM E/R and BCM is considered normal if the auto active test starts successfully.
- The auto active test facilitates troubleshooting if any systems controlled by IPDM E/R cannot be operated.

Diagnosis chart in auto active test mode

Symptom	Inspection contents	Possible cause	
Any of the following components do not operate <ul style="list-style-type: none"> • Parking lamps • License plate lamps • Tail lamps • Front fog lamps (if equipped) • Headlamp (HI, LO) • Front wiper 	Perform auto active test. Does the applicable system operate?	YES	BCM signal input circuit
		NO	<ul style="list-style-type: none"> • Lamp or motor • Lamp or motor ground circuit • Harness or connector between IPDM E/R and applicable system • IPDM E/R
A/C compressor does not operate	Perform auto active test. Does the magnet clutch operate?	YES	<ul style="list-style-type: none"> • Combination meter signal input circuit • CAN communication signal between combination meter and ECM • CAN communication signal between ECM and IPDM E/R
		NO	<ul style="list-style-type: none"> • Magnet clutch • Harness or connector between IPDM E/R and magnet clutch • IPDM E/R

DIAGNOSIS SYSTEM (IPDM E/R)

< FUNCTION DIAGNOSIS >

[HALOGEN TYPE]

Symptom	Inspection contents		Possible cause
Oil pressure warning lamp does not operate	Perform auto active test. Does the oil pressure warning lamp blink?	YES	<ul style="list-style-type: none"> • Harness or connector between IPDM E/R and oil pressure switch • Oil pressure switch • IPDM E/R
		NO	<ul style="list-style-type: none"> • CAN communication signal between IPDM E/R and BCM • CAN communication signal between BCM and combination meter • Combination meter
Cooling fan does not operate	Perform auto active test. Does the cooling fan operate?	YES	<ul style="list-style-type: none"> • ECM signal input circuit • CAN communication signal between ECM and IPDM E/R
		NO	<ul style="list-style-type: none"> • Cooling fan • Harness or connector between cooling fan and cooling fan relays • Cooling fan relays • Harness or connector between IPDM E/R and cooling fan relays • IPDM E/R

CONSULT - III Function (IPDM E/R)

INFOID:000000005530259

APPLICATION ITEM

CONSULT-III performs the following functions via CAN communication with IPDM E/R.

Diagnosis mode	Description
ECU Identification	Allows confirmation of IPDM E/R part number.
Self Diagnostic Result	Displays the diagnosis results judged by IPDM E/R.
Data Monitor	Displays the real-time input/output data from IPDM E/R input/output data.
Active Test	IPDM E/R can provide a drive signal to electronic components to check their operations.
CAN Diag Support Monitor	The results of transmit/receive diagnosis of CAN communication can be read.

SELF DIAGNOSTIC

Refer to [EXL-325, "DTC Index"](#).

DATA MONITOR

Monitor item

Monitor Item [Unit]	MAIN SIG- NALS	Description
MOTOR FAN REQ [1,2,3,4]	×	Displays the value of the cooling fan speed signal received from ECM via CAN communication.
AC COMP REQ [Off/On]	×	Displays the status of the A/C compressor request signal received from ECM via CAN communication.
TAIL&CLR REQ [Off/On]	×	Displays the status of the position light request signal received from BCM via CAN communication.
HL LO REQ [Off/On]	×	Displays the status of the low beam request signal received from BCM via CAN communication.
HL HI REQ [Off/On]	×	Displays the status of the high beam request signal received from BCM via CAN communication.

DIAGNOSIS SYSTEM (IPDM E/R)

[HALOGEN TYPE]

< FUNCTION DIAGNOSIS >

Monitor Item [Unit]	MAIN SIG- NALS	Description
FR FOG REQ [Off/On]	×	Displays the status of the front fog light request signal received from BCM via CAN communication.
FR WIP REQ [Stop/1LOW/Low/Hi]	×	Displays the status of the front wiper request signal received from BCM via CAN communication.
WIP AUTO STOP [STOP P/ACT P]	×	Displays the status of the front wiper auto stop signal judged by IPDM E/R.
WIP PROT [Off/BLOCK]	×	Displays the status of the front wiper fail-safe operation judged by IPDM E/R.
IGN RLY1 -REQ [Off/On]		Displays the status of the ignition switch ON signal received from BCM via CAN communication.
IGN RLY [Off/On]	×	Displays the status of the ignition relay judged by IPDM E/R.
PUSH SW [Off/On]		Displays the status of the push-button ignition switch judged by IPDM E/R.
INTER/NP SW [Off/On]		Displays the status of the CVT shift position judged by IPDM E/R.
ST RLY CONT [Off/On]		Displays the status of the starter relay status signal received from BCM via CAN communication.
IHBT RLY -REQ [Off/On]		Displays the status of the starter control relay signal received from BCM via CAN communication.
ST/INH RLY [Off/ ST /INH]		Displays the status of the starter relay and starter control relay judged by IPDM E/R.
DETENT SW [Off/On]		Displays the status of the CVT shift selector (detention switch) judged by IPDM E/R.
S/L RLY -REQ ¹ [Off/On]		Displays the status of the steering lock relay request received from BCM via CAN communication.
S/L STATE ¹ [LOCK/UNLK/UNKWN]		Displays the status of the electronic steering column lock judged by IPDM E/R.
DTRL REQ [Off]		Displays the status of the daytime light request signal received from BCM via CAN communication.
OIL P SW [Open/Close]		Displays the status of the oil pressure switch judged by IPDM E/R.
THFT HRN REQ [Off/On]		Displays the status of the theft warning horn request signal received from BCM via CAN communication.
HORN CHIRP [Off/On]		Displays the status of the horn reminder signal received from BCM via CAN communication.

1: Early production

ACTIVE TEST

Test item

Test item	Operation	Description
HORN	On	Operates horn relay 1 and horn relay 2 for 20 ms.
	Off	OFF
FRONT WIPER	Lo	Operates the front wiper relay.
	Hi	Operates the front wiper relay and front wiper high relay.
MOTOR FAN	1	OFF
	2	Outputs 50% pulse duty signal (PWM signal) to the cooling fan control module.
	3	Outputs 80% pulse duty signal (PWM signal) to the cooling fan control module.
	4	Outputs 100% pulse duty signal (PWM signal) to the cooling fan control module.

DIAGNOSIS SYSTEM (IPDM E/R)

< FUNCTION DIAGNOSIS >

[HALOGEN TYPE]

Test item	Operation	Description
EXTERNAL LAMPS	Off	OFF
	TAIL	Operates the tail lamp relay.
	Lo	Operates the headlamp low relay.
	Hi	Operates the headlamp low relay and ON/OFF the headlamp high relay at 1 second intervals.
	Fog	Operates the front fog lamp relay.

A
B
C
D
E
F
G
H
I
J
K
EXL
M
N
O
P

EXL

POWER SUPPLY AND GROUND CIRCUIT

< COMPONENT DIAGNOSIS >

[HALOGEN TYPE]

COMPONENT DIAGNOSIS

POWER SUPPLY AND GROUND CIRCUIT

BCM (BODY CONTROL MODULE)

BCM (BODY CONTROL MODULE) : Diagnosis Procedure

INFOID:000000005530162

Regarding Wiring Diagram information, refer to [EXL-296, "Wiring Diagram"](#).

1. CHECK FUSE AND FUSIBLE LINK

Check if the following BCM fuses or fusible link are blown.

Terminal No.	Signal name	Fuse and fusible link No.
1	Battery power supply	H
11		10
24		7

Is the fuse or fusible link blown?

- YES >> Replace the blown fuse or fusible link after repairing the affected circuit.
NO >> GO TO 2

2. CHECK POWER SUPPLY CIRCUIT

1. Turn ignition switch OFF.
2. Disconnect BCM.
3. Check voltage between BCM harness connector and ground.

Terminals		Voltage (Approx.)
(+)	(-)	
BCM		Ground Battery voltage
Connector	Terminal	
M16 (A)	1	
M17 (B)	11	
M18 (C)	24	

Is the measurement normal?

- YES >> GO TO 3
NO >> Repair or replace harness.

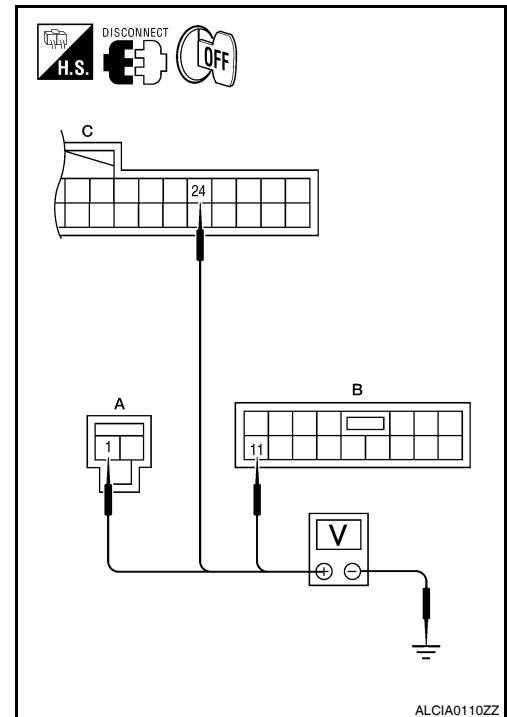

3. CHECK GROUND CIRCUIT

POWER SUPPLY AND GROUND CIRCUIT

[HALOGEN TYPE]

< COMPONENT DIAGNOSIS >

Check continuity between BCM harness connector and ground.

BCM		Ground	Continuity
Connector	Terminal		
M17	13		Yes

Does continuity exist?

- YES >> Inspection End.
- NO >> Repair or replace harness.

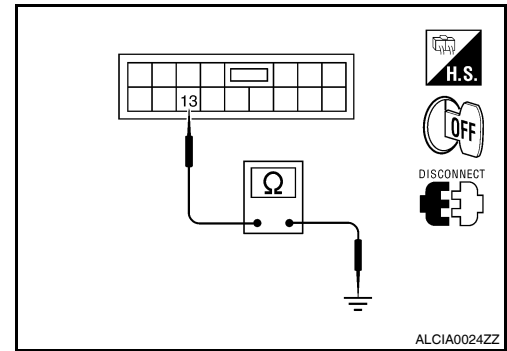

BCM (BODY CONTROL MODULE) : Special Repair Requirement

INFOID:000000005530163

1. REQUIRED WORK WHEN REPLACING BCM

Initialize control unit. Refer to [BCS-6, "CONFIGURATION \(BCM\) : Special Repair Requirement"](#).

>> Work End.

IPDM E/R (INTELLIGENT POWER DISTRIBUTION MODULE ENGINE ROOM)

IPDM E/R (INTELLIGENT POWER DISTRIBUTION MODULE ENGINE ROOM) : Diagnosis Procedure

INFOID:000000005530263

Regarding Wiring Diagram information, refer to [EXL-318, "Wiring Diagram"](#).

1. CHECK FUSES AND FUSIBLE LINK

Check that the following IPDM E/R fuses or fusible link are not blown.

Terminal No.	Signal name	Fuses and fusible link No.
1, 2	Battery power supply	B, D
—		42
—		43

Is the fuse blown?

- YES >> Replace the blown fuse or fusible link after repairing the affected circuit.
- NO >> GO TO 2

2. CHECK POWER SUPPLY CIRCUIT

1. Turn ignition switch OFF.
2. Disconnect IPDM E/R connectors.
3. Check voltage between IPDM E/R harness connector and ground.

Terminals		Ground	Voltage (V) (Approx.)
(+)	(-)		
IPDM E/R		Ground	Battery voltage
Connector	Terminal		
E16	1 2		

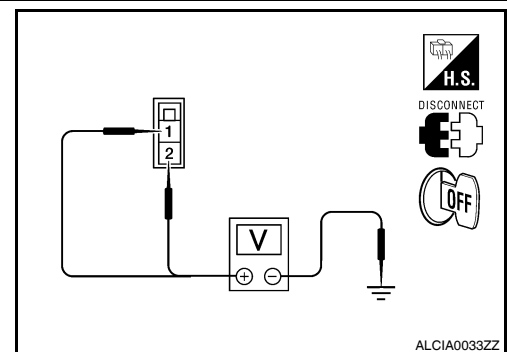

Is the measurement value normal?

- YES >> GO TO 3
- NO >> Repair harness or connector.

POWER SUPPLY AND GROUND CIRCUIT

< COMPONENT DIAGNOSIS >

[HALOGEN TYPE]

3. CHECK GROUND CIRCUIT

Check continuity between IPDM E/R harness connectors and ground.

IPDM E/R		Ground	Continuity
Connector	Terminal		
A: E18	12		Yes
B: E17	41		

Does continuity exist?

- YES >> Inspection End.
- NO >> Repair harness or connector.

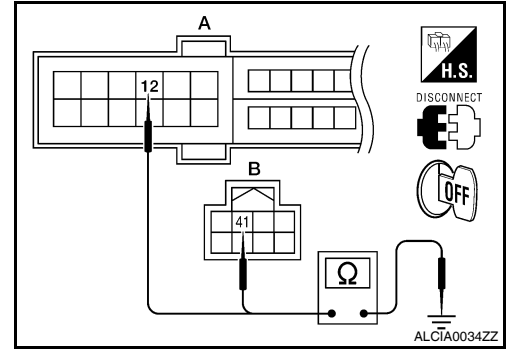

HEADLAMP (HI) CIRCUIT

< COMPONENT DIAGNOSIS >

[HALOGEN TYPE]

HEADLAMP (HI) CIRCUIT

Description

INFOID:000000005460964

The IPDM E/R (intelligent power distribution module engine room) controls the headlamp high relay based on inputs from the BCM over the CAN communication lines. When the headlamp high relay is energized, power flows through fuses 48 and 49, located in the IPDM E/R. Power then flows to the front combination lamps to the headlamp high beam.

Component Function Check

INFOID:000000005460965

1. CHECK HEADLAMP (HI) OPERATION

⊗ WITHOUT CONSULT-III

1. Start IPDM E/R auto active test. Refer to [PCS-14, "Diagnosis Description"](#).
2. Check that the headlamp switches to the high beam.

NOTE:

HI/LO is repeated 1 second each when using the IPDM E/R auto active test.

Ⓜ CONSULT-III

1. Select "EXTERNAL LAMPS" of IPDM E/R active test item.
2. While operating the test item, check that the headlamp switches to the high beam.

HI : Headlamp switches to the high beam.

OFF : Headlamp OFF

Does the headlamp switch to the high beam?

YES >> Headlamp (HI) circuit is normal.

NO >> Refer to [EXL-211, "Diagnosis Procedure"](#).

Diagnosis Procedure

INFOID:000000005460966

Regarding Wiring Diagram information, refer to [EXL-227, "Wiring Diagram"](#).

1. CHECK HEADLAMP (HI) FUSES

1. Turn the ignition switch OFF.
2. Check that the following fuses are not open.

Unit	Location	Fuse No.	Capacity
Headlamp HI (LH)	IPDM E/R	48	10A
Headlamp HI (RH)	IPDM E/R	49	10A

Is the fuse open?

YES >> Repair the harness and replace the fuse.

NO >> GO TO 2.

2. CHECK HEADLAMP (HI) OUTPUT VOLTAGE

Ⓜ CONSULT-III ACTIVE TEST

1. Turn the ignition switch OFF.
2. Disconnect the front combination lamp connector.
3. Turn the ignition switch ON.
4. Select "EXTERNAL LAMPS" of IPDM E/R active test item.

A
B
C
D
E
F
G
H
I
J
K
L
M
N
O
P

EXL

HEADLAMP (HI) CIRCUIT

[HALOGEN TYPE]

< COMPONENT DIAGNOSIS >

- With EXTERNAL LAMP ON, check the voltage between the combination lamp connector and ground.

(+)		Terminal	(-)	Voltage
Connector				
RH	E222	3	Ground	Battery voltage
LH	E213	3		

Is battery voltage present?

- YES >> GO TO 4.
NO >> GO TO 3.

3. CHECK HEADLAMP (HI) CIRCUIT FOR OPEN

- Turn the ignition switch OFF.
- Disconnect IPDM E/R connector.
- Check continuity between the IPDM E/R harness connector and the front combination lamp harness connector.

A		B		Continuity
Connector	Terminal	Connector	Terminal	
RH	E200	89	E222 3	Yes
LH		90	E213 3	

Does continuity exist?

- YES >> Replace IPDM E/R. Refer to [PCS-41. "Removal and Installation"](#).
NO >> Repair the harnesses or connectors.

4. CHECK FRONT COMBINATION LAMP (HI) GROUND CIRCUIT

Check continuity between the front combination lamp harness connector terminal and ground.

Connector	Terminal	—	Continuity
RH	E222	Ground	Yes
LH	E213		

Does continuity exist?

- YES >> Inspect the headlamp bulb.
NO >> Repair the harness.

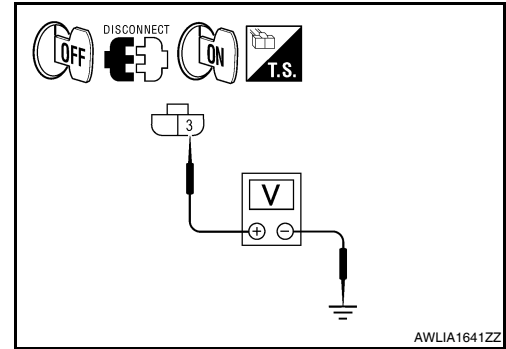

AWLIA1641ZZ

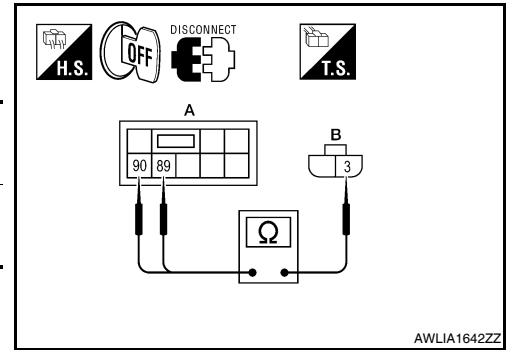

AWLIA1642ZZ

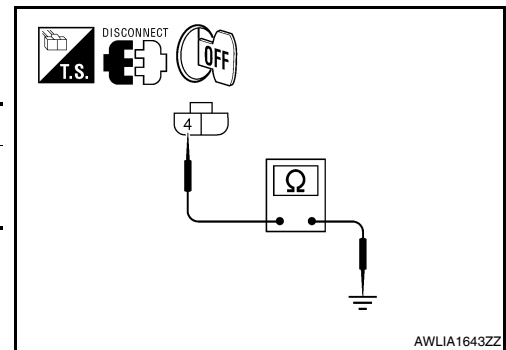

AWLIA1643ZZ

HEADLAMP (LO) CIRCUIT

< COMPONENT DIAGNOSIS >

[HALOGEN TYPE]

HEADLAMP (LO) CIRCUIT

Description

INFOID:000000005460967

The IPDM E/R (intelligent power distribution module engine room) controls the headlamp low relay based on inputs from the BCM over the CAN communication lines. When the headlamp low relay is energized, power flows through fuses 51 and 52, located in the IPDM E/R. Power then flows to the front combination lamps to the headlamp low beam.

Component Function Check

INFOID:000000005460968

1. CHECK HEADLAMP (LO) OPERATION

⊗ WITHOUT CONSULT-III

1. Start IPDM E/R auto active test. Refer to [PCS-14, "Diagnosis Description"](#).
2. Check that the headlamp is turned ON.

NOTE:

HI/LO is repeated 1 second each when using the IPDM E/R auto active test.

Ⓜ CONSULT-III

1. Select "EXTERNAL LAMPS" of IPDM E/R active test item.
2. While operating the test item, check that the headlamp is turned ON.

LO : Headlamp ON

OFF : Headlamp OFF

Is the headlamp turned ON?

YES >> Headlamp (LO) is normal.

NO >> Refer to [EXL-213, "Diagnosis Procedure"](#).

Diagnosis Procedure

INFOID:000000005460969

Regarding Wiring Diagram information, refer to [EXL-227, "Wiring Diagram"](#).

1. CHECK HEADLAMP (LO) FUSES

1. Turn the ignition switch OFF.
2. Check that the following fuses are not open.

Unit	Location	Fuse No.	Capacity
Headlamp LO (LH)	IPDM E/R	51	15A
Headlamp LO (RH)	IPDM E/R	52	15A

Is the fuse open?

YES >> Repair the harness and replace the fuse.

NO >> GO TO 2.

2. CHECK HEADLAMP (LO) OUTPUT VOLTAGE

Ⓜ CONSULT-III

1. Turn the ignition switch OFF.
2. Disconnect the front combination lamp connector.
3. Turn the ignition switch ON.
4. Select "EXTERNAL LAMPS" of IPDM E/R active test item.

HEADLAMP (LO) CIRCUIT

[HALOGEN TYPE]

< COMPONENT DIAGNOSIS >

- With EXTERNAL LAMPS ON, check the voltage between the combination lamp connector and ground.

(+)		Terminal	(-)	Voltage
Connector				
RH	E223	1	Ground	Battery voltage
LH	E212	1		

Is battery voltage present?

- YES >> GO TO 4.
NO >> GO TO 3.

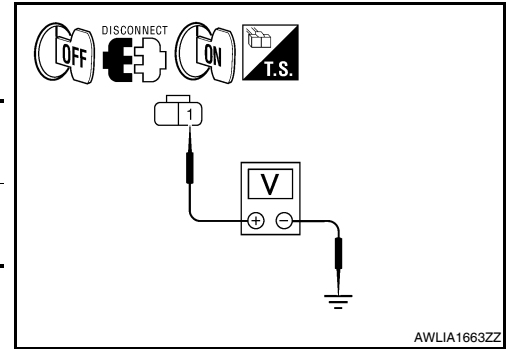

3. CHECK HEADLAMP (LO) CIRCUIT FOR OPEN

- Turn the ignition switch OFF.
- Disconnect IPDM E/R connector.
- Check continuity between the IPDM E/R harness connector and the front combination lamp harness connector.

A		B		Continuity
Connector	Terminal	Connector	Terminal	
RH	E200	E223	1	Yes
LH		E212	1	

Does continuity exist?

- YES >> Replace the IPDM E/R. Refer to [PCS-41. "Removal and Installation"](#).
NO >> Repair the harnesses or connectors.

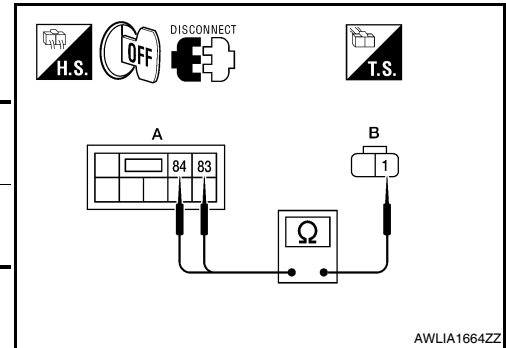

4. CHECK FRONT COMBINATION LAMP (LO) GROUND CIRCUIT

- Disconnect the front combination lamp connector.
- Check continuity between the front combination lamp harness connector terminal and ground.

Connector	Terminal	—	Continuity
RH	E223	Ground	Yes
LH	E212		

Does continuity exist?

- YES >> Inspect the headlamp bulb.
NO >> Repair the harness.

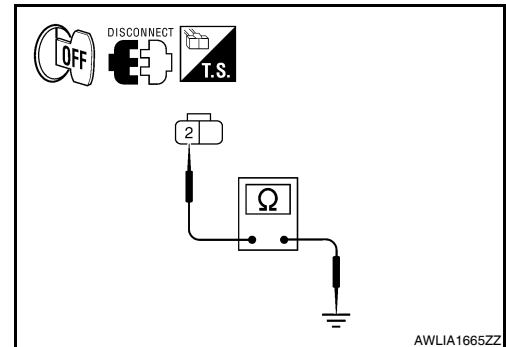

FRONT FOG LAMP CIRCUIT

[HALOGEN TYPE]

< COMPONENT DIAGNOSIS >

FRONT FOG LAMP CIRCUIT

Description

INFOID:000000005531153

The IPDM E/R (intelligent power distribution module engine room) controls the front fog lamp relay based on inputs from the BCM over the CAN communication lines. When the front fog lamp relay is energized, power flows from the front fog lamp relay in the IPDM E/R to the front fog lamps.

Component Function Check

INFOID:000000005531154

1. CHECK FRONT FOG LAMP OPERATION

WITHOUT CONSULT-III

1. Activate IPDM E/R auto active test. Refer to [PCS-14, "Diagnosis Description"](#).
2. Check that the front fog lamp is turned ON.

CONSULT-III

1. Select "EXTERNAL LAMPS" of IPDM E/R active test item.
2. While operating the test item, check that the front fog lamp is turned ON.

FOG : Front fog lamp ON

OFF : Front fog lamp OFF

Is the front fog lamp turned ON?

- YES >> Front fog lamp circuit is normal.
NO >> Refer to [EXL-215, "Diagnosis Procedure"](#).

Diagnosis Procedure

INFOID:000000005531155

Regarding Wiring Diagram information, refer to [EXL-245, "Wiring Diagram"](#).

1. CHECK FRONT FOG LAMP FUSE

1. Turn the ignition switch OFF.
2. Check that the following fuses are not open.

Unit	Location	Fuse No.	Capacity
Front fog lamp	IPDM E/R	53	15A

Is the fuse open?

- YES >> Repair the harness and replace the fuse.
NO >> GO TO 2.

2. CHECK FRONT FOG LAMP OUTPUT VOLTAGE

CONSULT-III

1. Turn the ignition switch OFF.
2. Disconnect the front fog lamp connector.
3. Turn the ignition switch ON.
4. Select "EXTERNAL LAMPS" of IPDM E/R active test item.

FRONT FOG LAMP CIRCUIT

[HALOGEN TYPE]

< COMPONENT DIAGNOSIS >

- With EXTERNAL LAMPS ON, check the voltage between the fog lamp connector and ground.

(+)		Terminal	(-)	Voltage
Connector				
LH	E214	1	Ground	Battery voltage
RH	E227	1		

Is battery voltage present?

- YES >> GO TO 4.
NO >> GO TO 3.

3. CHECK FRONT FOG LAMP OPEN CIRCUIT

- Turn the ignition switch OFF.
- Disconnect IPDM E/R connector.
- Check continuity between the IPDM E/R harness connector and the front fog lamp harness connector.

A		B		Continuity
Connector	Terminal	Connector	Terminal	
RH	E200	E227	86	Yes
LH			87	
		E214	1	

Does continuity exist?

- YES >> Replace the IPDM E/R. Refer to [PCS-41. "Removal and Installation"](#).
NO >> Repair the harnesses or connectors.

4. CHECK FRONT FOG LAMP GROUND CIRCUIT

Check continuity between the front fog lamp harness connector terminal and ground.

Connector	Terminal	—	Continuity
RH	E227	Ground	Yes
LH	E214		

Does continuity exist?

- YES >> Inspect the fog lamp bulb.
NO >> Repair the harness.

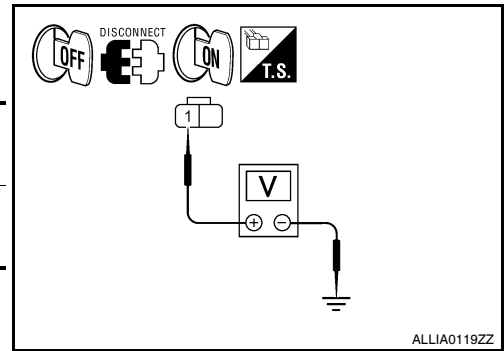

ALLIA0119ZZ

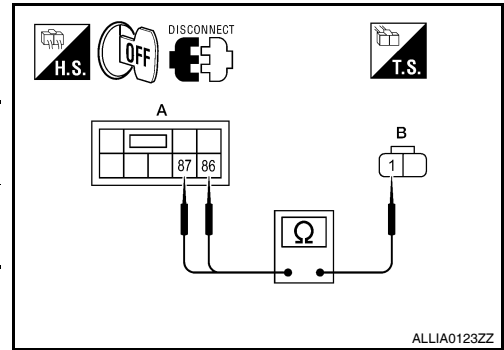

ALLIA0123ZZ

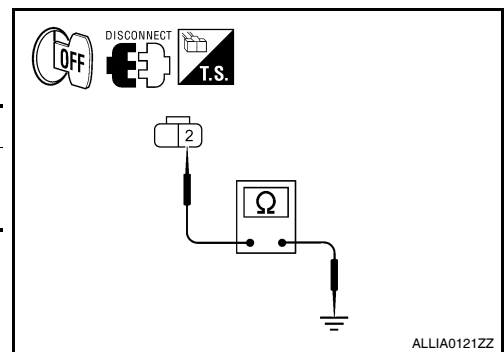

ALLIA0121ZZ

PARKING LAMP CIRCUIT

< COMPONENT DIAGNOSIS >

[HALOGEN TYPE]

PARKING LAMP CIRCUIT

Description

INFOID:000000005531156

The IPDM E/R (intelligent power distribution module engine room) controls the tail lamp relay based on inputs from the BCM over the CAN communication lines. When the tail lamp relay is energized, power flows through fuses 46 and 47, located in the IPDM E/R. Power then flows to the front and rear combination lamps.

Component Function Check

INFOID:000000005531157

1. CHECK PARKING LAMP OPERATION

WITHOUT CONSULT-III

1. Activate IPDM E/R auto active test. Refer to [PCS-14, "Diagnosis Description"](#).
2. Check that the parking lamp is turned ON.

CONSULT-III

1. Select "EXTERNAL LAMPS" of IPDM E/R active test item.
2. While operating the test item, check that the parking lamp is turned ON.

TAIL : Parking lamp ON

OFF : Parking lamp OFF

Is the parking lamp turned ON?

- YES >> Parking lamp circuit is normal.
NO >> Refer to [EXL-217, "Diagnosis Procedure"](#).

Diagnosis Procedure

INFOID:000000005531158

Regarding Wiring Diagram information, refer to [EXL-257, "Wiring Diagram"](#).

1. CHECK PARKING LAMP FUSES

1. Turn the ignition switch OFF.
2. Check that the following fuses are not open.

Unit	Location	Fuse No.	Capacity
Parking lamps (front)	IPDM E/R	46	10A
Parking lamps (rear)	IPDM E/R	47	10A

Is the fuse open?

- YES >> Repair the harness and replace the fuse.
NO >> GO TO 2.

2. CHECK TAIL LAMP RELAY OUTPUT (VOLTAGE)

CONSULT-III

1. Turn the ignition switch OFF.
2. Disconnect the front and rear combination lamp connectors.
3. Turn the ignition switch ON.
4. Select "EXTERNAL LAMPS" of IPDM E/R active test item.

A
B
C
D
E
F
G
H
I
J
K
L
M
N
O
P

EXL

PARKING LAMP CIRCUIT

[HALOGEN TYPE]

< COMPONENT DIAGNOSIS >

5. With EXTERNAL LAMPS ON, check the voltage between the front combination lamp connector and ground.

(+)		Terminal	(-)	Voltage
Connector				
LH	E217	5	Ground	Battery voltage
RH	E224			

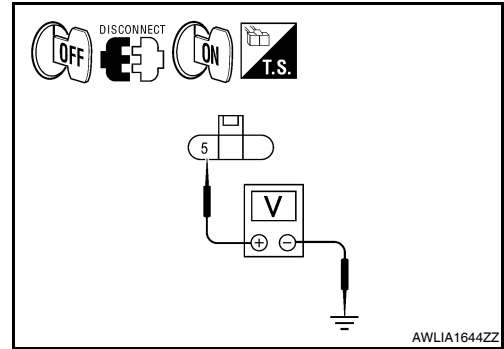

AWLIA1644ZZ

6. With EXTERNAL LAMPS ON, check the voltage between the rear combination lamp connector and ground.

(+)		Terminal	(-)	Voltage
Connector				
LH	B30	1	Ground	Battery voltage
RH	B45			

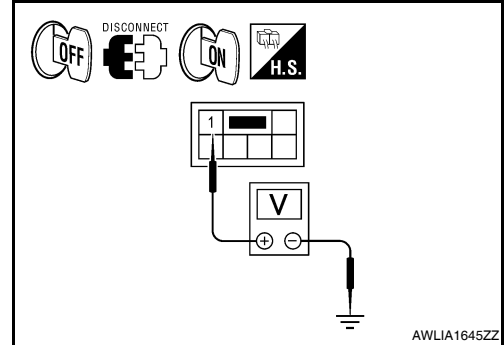

AWLIA1645ZZ

7. With EXTERNAL LAMP ON, check the voltage between the license plate lamp connector and ground.

(+)		Terminal	(-)	Voltage
Connector				
LH	T6	1	Ground	Battery voltage
RH	T8			

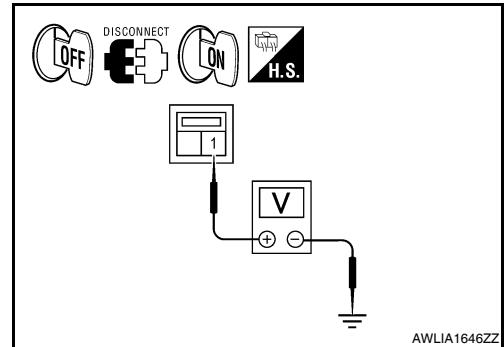

AWLIA1646ZZ

Is battery voltage present?

- YES >> GO TO 4.
NO >> GO TO 3.

3. CHECK PARKING LAMP CIRCUIT (OPEN)

- Turn the ignition switch OFF.
- Disconnect IPDM E/R connector.
- Check continuity between the IPDM E/R harness connector (A) and the front combination lamp harness connector (B).

A		B		Continuity
Connector	Terminal	Connector	Terminal	
LH	E201	E217	5	Yes
RH		E224		

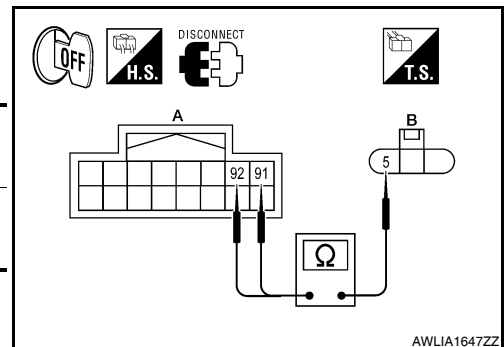

AWLIA1647ZZ

PARKING LAMP CIRCUIT

[HALOGEN TYPE]

< COMPONENT DIAGNOSIS >

4. Check continuity between the IPDM E/R harness connector (A) and the rear combination lamp harness connector (B).

A			B		Continuity
Connector	Terminal		Connector	Terminal	
LH	E18	7	B30	1	Yes
RH			B45		

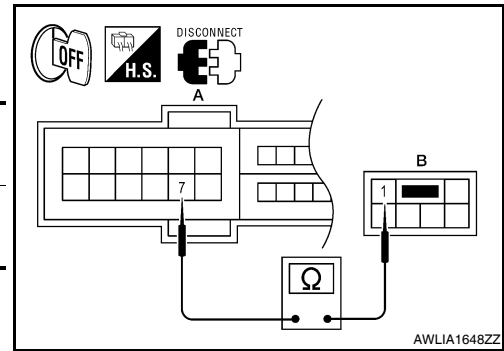

5. Check continuity between the IPDM E/R harness connector (A) and the license plate lamp harness connector (B).

A			B		Continuity
Connector	Terminal		Connector	Terminal	
LH	E18	7	T6	1	Yes
RH			T8		

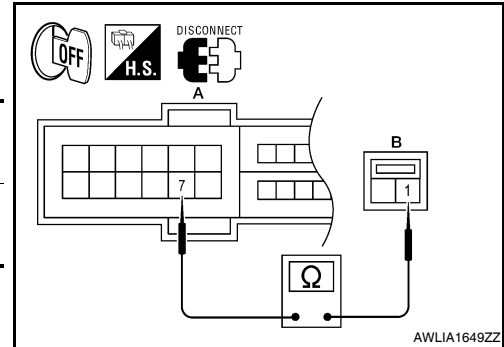

Does continuity exist?

YES >> Replace the IPDM E/R. Refer to [PCS-41. "Removal and Installation"](#).

NO >> Repair the harnesses or connectors.

4. CHECK PARKING LAMP GROUND CIRCUIT

1. Check continuity between the front combination lamp harness connector terminal and ground.

(+)			(-)	Continuity
Connector	Terminal			
LH	E217	6	Ground	Yes
RH	E224			

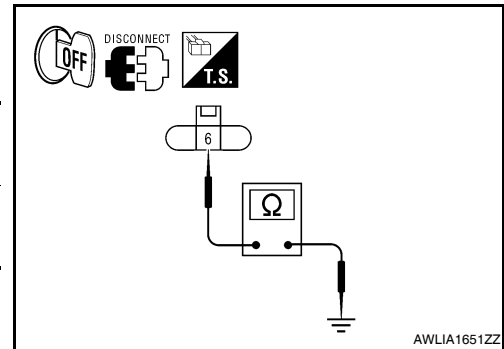

2. Check continuity between the rear combination lamp harness connector terminal and ground.

(+)			(-)	Continuity
Connector	Terminal			
LH	B30	4	Ground	Yes
RH	B45			

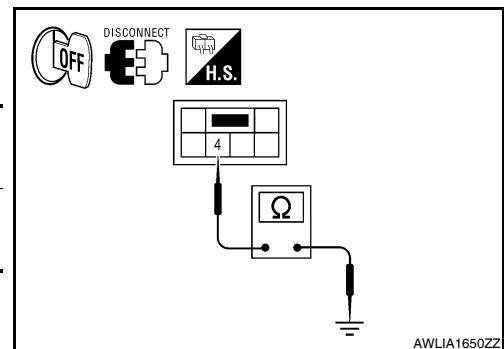

A
B
C
D
E
F
G
H
I
J
K
EXL
M
N
O
P

PARKING LAMP CIRCUIT

[HALOGEN TYPE]

< COMPONENT DIAGNOSIS >

3. Check continuity between the license plate lamp harness connector terminal and ground.

(+)		Terminal	(-)	Continuity
Connector				
LH	T6	2	Ground	Yes
RH	T8			

Does continuity exist?

- YES >> Inspect the parking lamp bulb.
NO >> Repair the harness.

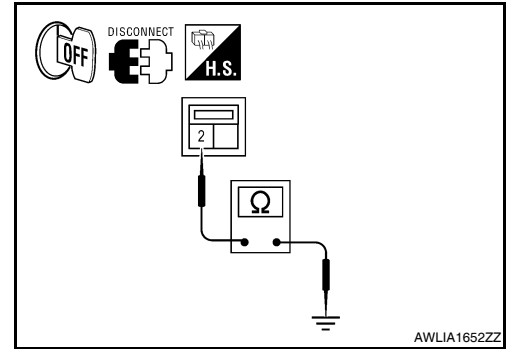

TURN SIGNAL LAMP CIRCUIT

< COMPONENT DIAGNOSIS >

[HALOGEN TYPE]

TURN SIGNAL LAMP CIRCUIT

Description

INFOID:000000005531159

The BCM monitors inputs from the combination switch to determine when to activate the turn signals. The BCM outputs voltage direction to the left and right turn signals during turn signal operation or both during hazard warning operation. The BCM sends a turn signal indicator request to the combination meter via the CAN communication lines.

The BCM performs the fast flasher operation (fail-safe) if any bulb or harness of the turn signal lamp circuit is open.

NOTE:

Turn signal lamp blinks at normal speed when using the hazard warning lamp.

Component Function Check

INFOID:000000005531160

1. CHECK TURN SIGNAL LAMP

CONSULT-III

1. Select "FLASHER" of BCM (FLASHER) active test item.
2. While operating the test item, check that the turn signal lamp blinks.

- LH** : Turn signal lamp LH blinking
- RH** : Turn signal lamp RH blinking
- OFF** : The turn signal lamp OFF

Does the turn signal lamp blink?

- YES >> Turn signal lamp circuit is normal.
- NO >> Refer to [EXL-221, "Diagnosis Procedure"](#).

Diagnosis Procedure

INFOID:000000005531161

Regarding Wiring Diagram information, refer to [EXL-249, "Wiring Diagram"](#).

1. CHECK TURN SIGNAL LAMP BULB

Check the applicable lamp bulb to be sure the proper bulb standard is in use and the bulb is not open.

Is the bulb OK?

- YES >> GO TO 2.
- NO >> Replace the bulb.

2. CHECK TURN SIGNAL LAMP OUTPUT VOLTAGE

While operating the turn signal switch, check the voltage between the BCM harness connector and the ground.

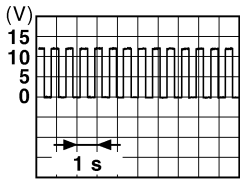
(+)		(-)	Voltage
Connector	Terminal		
RH	M17	Ground	
LH	M17		

PKID0926E

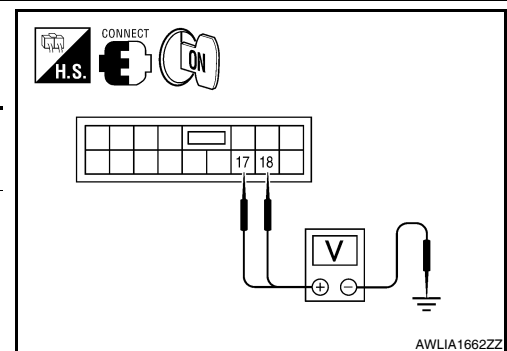

Is the measurement value normal?

- YES >> GO TO 3.
- NO >> Replace BCM. Refer to [BCS-87, "Removal and Installation"](#).

A
B
C
D
E
F
G
H
I
J
K
L
M
N
O
P

EXL

TURN SIGNAL LAMP CIRCUIT

[HALOGEN TYPE]

< COMPONENT DIAGNOSIS >

3. CHECK TURN SIGNAL LAMP CIRCUIT FOR OPEN

1. Turn the ignition switch OFF.
2. Disconnect BCM connector, front combination lamp connector, door mirror connector (with turn signal in mirror) and rear combination lamp connector.
3. Check continuity between the BCM harness connector (A) and the front combination lamp connector (B).

A		B		Continuity
Connector	Terminal	Connector	Terminal	
LH	M17	18	E217	Yes
RH		17	E224	

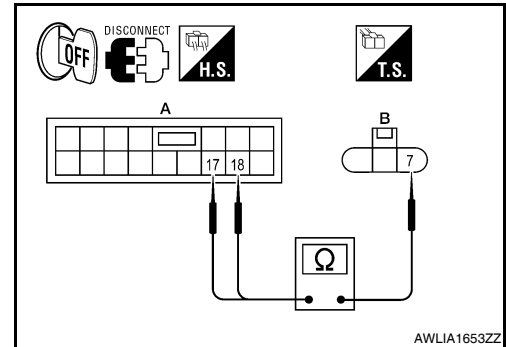

4. Check continuity between the BCM harness connector (A) and the rear combination lamp harness connector (B).

A		B		Continuity
Connector	Terminal	Connector	Terminal	
LH	M17	18	B30	Yes
RH		17	B45	

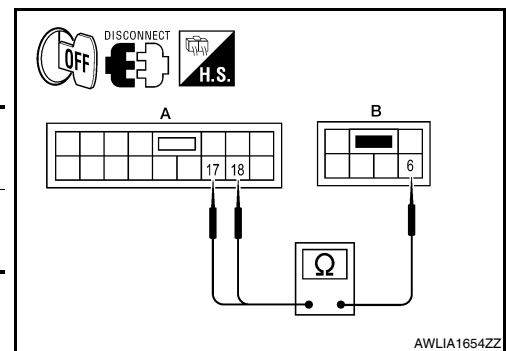

5. Check continuity between the BCM harness connector (A) and the door mirror connector (B) (if equipped with turn signal in mirror).

A		B		Continuity
Connector	Terminal	Connector	Terminal	
LH	M17	D4	8	Yes
RH		D107		

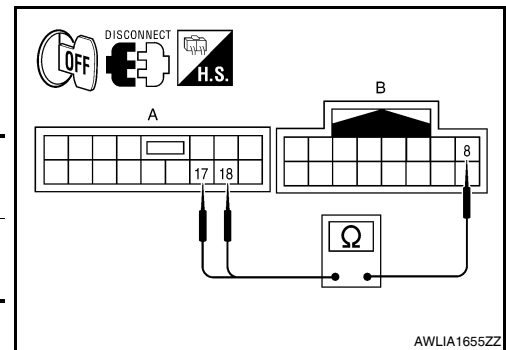

Does continuity exist?

YES >> GO TO 4.

NO >> Repair the harnesses or connectors.

4. CHECK TURN SIGNAL LAMP SHORT CIRCUIT

Check continuity between the BCM harness connector and ground.

Connector	Terminal	—	Continuity
LH	M17	Ground	No
RH			

Does continuity exist?

YES >> Repair the harnesses or connectors.

NO >> GO TO 5.

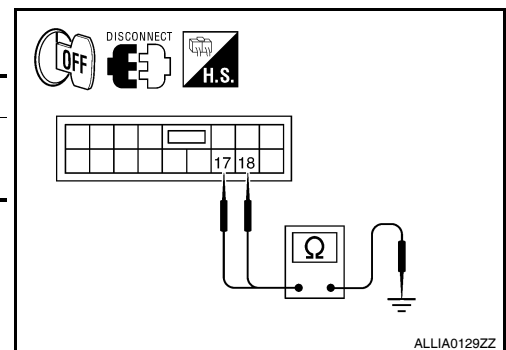

5. CHECK TURN SIGNAL LAMP GROUND CIRCUIT

TURN SIGNAL LAMP CIRCUIT

[HALOGEN TYPE]

< COMPONENT DIAGNOSIS >

1. Check continuity between the front combination lamp and ground.

Connector		Terminal	—	Continuity
LH	E217	6	Ground	Yes
RH	E224			

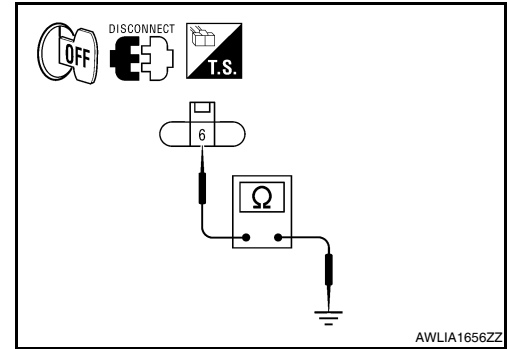

2. Check continuity between the rear combination lamp and ground.

Connector		Terminal	—	Continuity
LH	B30	4	Ground	Yes
RH	B45			

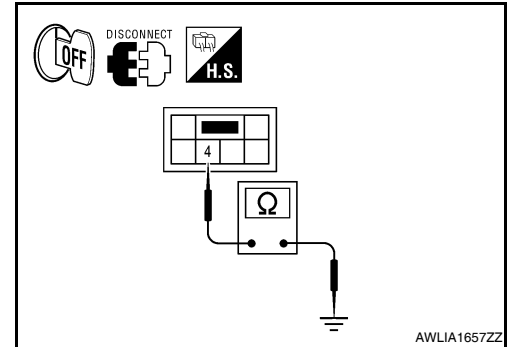

3. Check continuity between the door mirror and ground (if equipped with turn signal in mirror).

Connector		Terminal	—	Continuity
LH	D4	8	Ground	Yes
RH	D107			

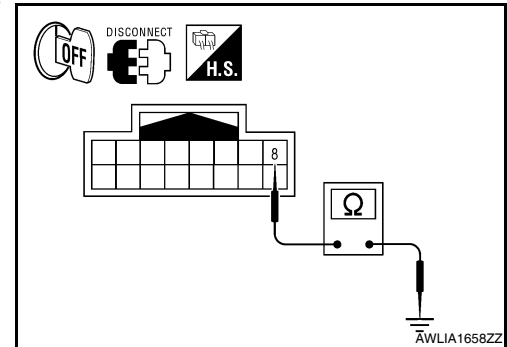

Does continuity exist?

- YES >> Replace the front combination lamp, the rear combination lamp or door mirror (if equipped with turn signal in mirror).
- NO >> Repair the harnesses or connectors.

A
B
C
D
E
F
G
H
I
J
K
EXL
M
N
O
P

OPTICAL SENSOR

< COMPONENT DIAGNOSIS >

[HALOGEN TYPE]

OPTICAL SENSOR

Description

INFOID:000000005531162

The optical sensor converts the outside brightness (lux) to voltage and transmits the optical sensor signal to the BCM.

Component Function Check

INFOID:000000005531163

1. CHECK OPTICAL SENSOR SIGNAL BY CONSULT-III

CONSULT-III

1. Turn the ignition switch ON.
2. Select "OPTICAL SENSOR" of BCM (HEAD LAMP) DATA MONITOR item.
3. Turn the lighting switch to AUTO.
4. While the auto light system is operating, check the monitor status.

Monitor item	Condition	Voltage
OPTICAL SENSOR	When illuminating	3.1V or more *
	When shutting off light	0.6V or less

*: Illuminates the optical sensor. The value may be less than the standard value if brightness is weak.

Is the item status normal?

- YES >> Optical sensor is normal.
NO >> Refer to [EXL-224, "Diagnosis Procedure"](#).

Diagnosis Procedure

INFOID:000000005531164

Regarding Wiring Diagram information, refer to [EXL-239, "Wiring Diagram"](#).

1. CHECK OPTICAL SENSOR POWER SUPPLY INPUT

1. Turn the ignition switch ON.
2. Turn the lighting switch to AUTO.
3. Check the voltage between the optical sensor harness connector and ground.

(+)		(-)	Voltage
Connector	Terminal		
M66	1	Ground	5V

Is the voltage reading as specified?

- YES >> GO TO 2.
NO >> GO TO 4.

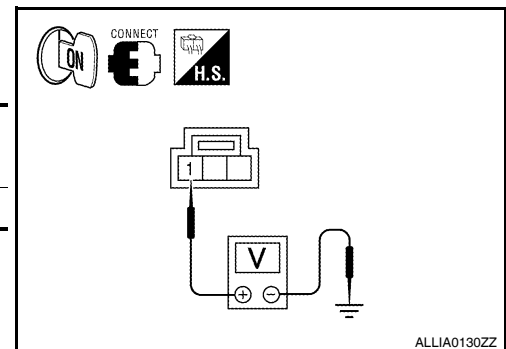

2. CHECK OPTICAL SENSOR GROUND INPUT

Check the voltage between the optical sensor harness connector and ground.

(+)		(-)	Voltage
Connector	Terminal		
M66	3	Ground	Less than 0.2V

Is the voltage reading as specified?

- YES >> GO TO 3.
NO >> GO TO 6.

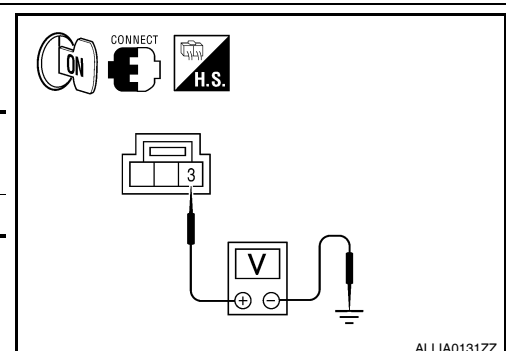

OPTICAL SENSOR

[HALOGEN TYPE]

< COMPONENT DIAGNOSIS >

3. CHECK OPTICAL SENSOR SIGNAL OUTPUT

With the auto light system operating, check voltage between the optical sensor harness connector and ground.

(+)		(-)	Condition	Voltage
Connector	Terminal			
M66	2	Ground	When illuminating	3.1V or more *
			When shutting off light	0.6V or less

*: Illuminate the optical sensor. The value may be less than the standard if brightness is weak.

Is the voltage reading as specified?

YES >> GO TO 7.

NO >> Replace the optical sensor. Refer to [EXL-343, "Removal and Installation"](#).

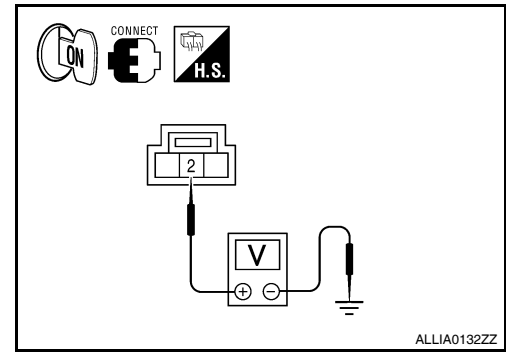

4. CHECK OPTICAL SENSOR POWER SUPPLY FOR OPEN CIRCUIT

1. Turn the ignition switch OFF.
2. Disconnect the optical sensor connector and BCM connector.
3. Check continuity between the optical sensor harness connector and the BCM harness connector.

A		B		Continuity
Connector	Terminal	Connector	Terminal	
M66	1	M18	46	Yes

Does continuity exist?

YES >> GO TO 5.

NO >> Repair the harnesses or connectors.

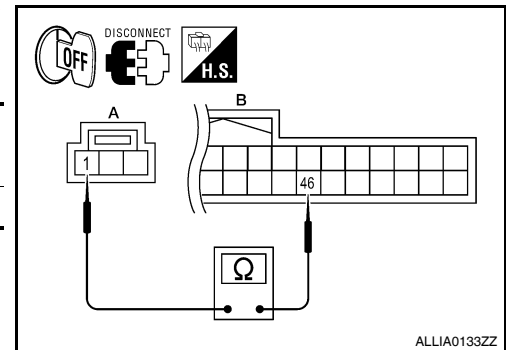

5. CHECK OPTICAL SENSOR POWER SUPPLY FOR SHORT CIRCUIT

Check the continuity between the optical sensor harness connector and the ground.

Connector	Terminal	—	Continuity
M66	1	Ground	No

Does continuity exist?

YES >> Repair the harnesses or connectors.

NO >> Replace BCM. Refer to [BCS-87, "Removal and Installation"](#).

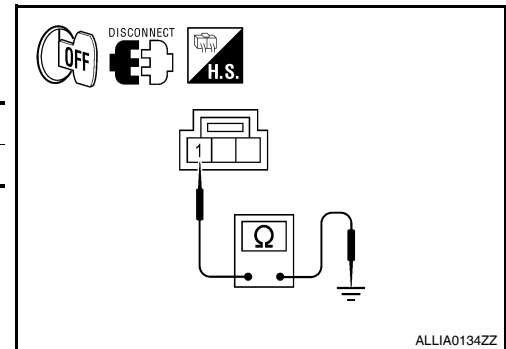

6. CHECK OPTICAL SENSOR GROUND FOR OPEN CIRCUIT

1. Turn the ignition switch OFF.
2. Disconnect the optical sensor connector and BCM connector.
3. Check continuity between the optical sensor harness connector and the BCM harness connector.

A		B		Continuity
Connector	Terminal	Connector	Terminal	
M66	3	M18	45	Yes

Does continuity exist?

YES >> Replace BCM. Refer to [BCS-87, "Removal and Installation"](#).

NO >> Repair the harnesses or connectors.

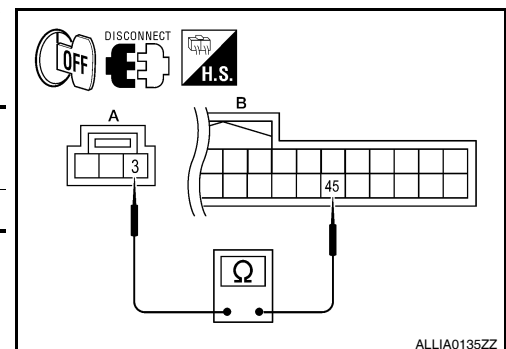

OPTICAL SENSOR

[HALOGEN TYPE]

< COMPONENT DIAGNOSIS >

7. CHECK OPTICAL SENSOR SIGNAL FOR OPEN CIRCUIT

1. Turn the ignition switch OFF.
2. Disconnect the optical sensor connector and BCM connector.
3. Check continuity between the optical sensor harness connector and the BCM harness connector.

A		B		Continuity
Connector	Terminal	Connector	Terminal	
M66	2	M18	21	Yes

Does continuity exist?

- YES >> GO TO 8.
 NO >> Repair the harnesses or connectors.

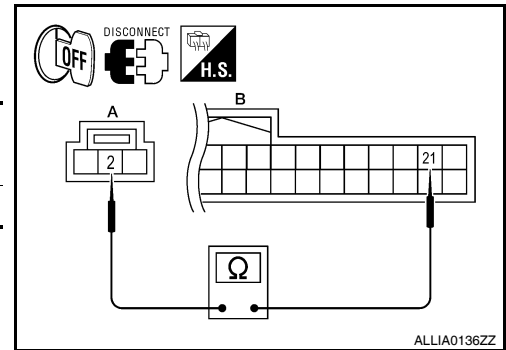

ALLIA0136ZZ

8. CHECK OPTICAL SENSOR SIGNAL FOR SHORT CIRCUIT

Check the continuity between the optical sensor harness connector and ground.

Connector	Terminal	—	Continuity
M66	2	Ground	No

Does continuity exist?

- YES >> Repair the harnesses or connectors.
 NO >> Replace BCM. Refer to [BCS-87. "Removal and Installation"](#).

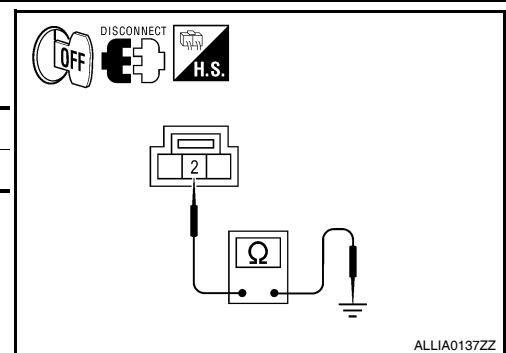

ALLIA0137ZZ

HEADLAMP

< COMPONENT DIAGNOSIS >

[HALOGEN TYPE]

HEADLAMP

Wiring Diagram

INFOID:000000005460982

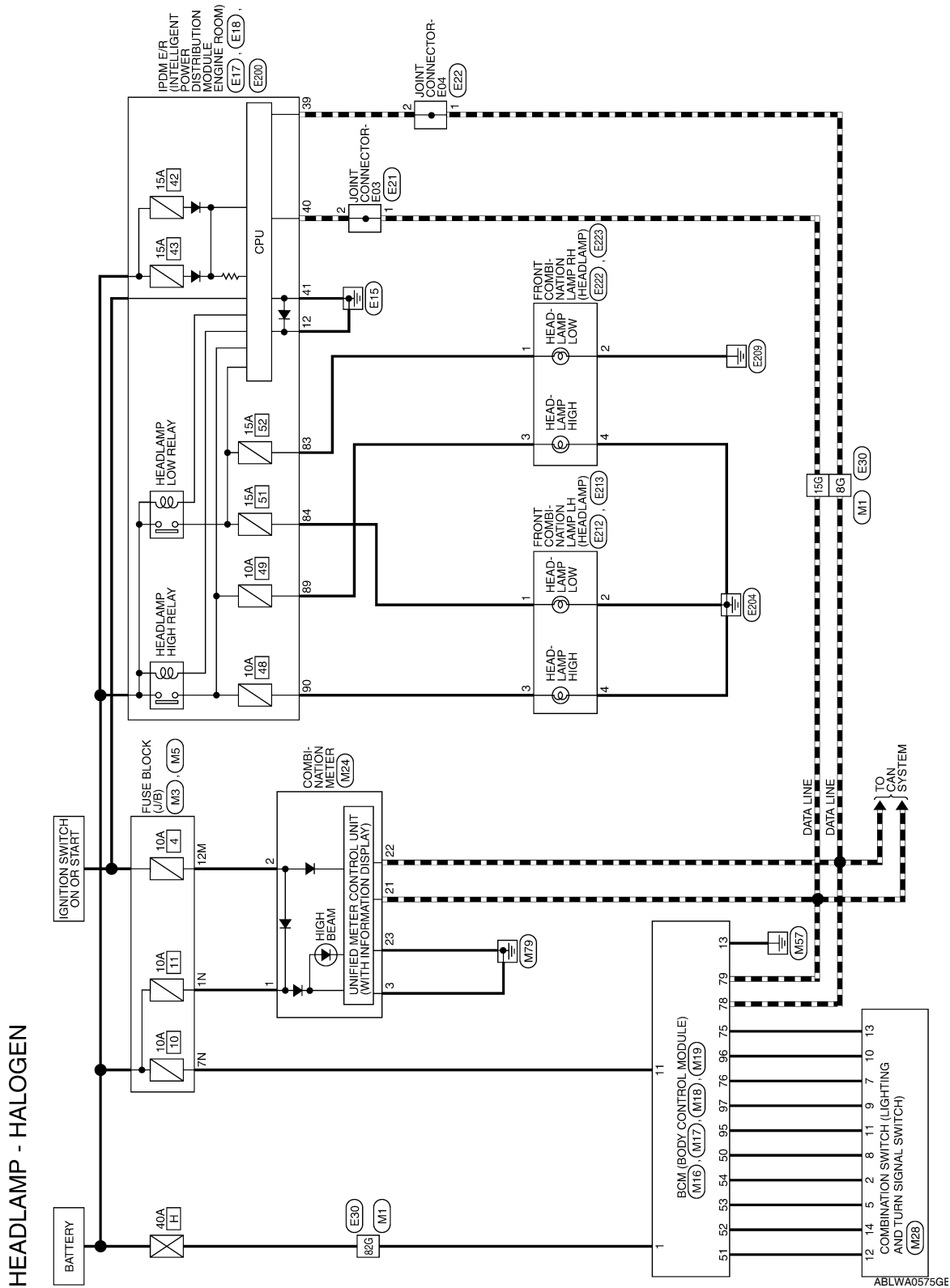

A
B
C
D
E
F
G
H
I
J
K
L
M
N
O
P

EXL

HEADLAMP

< COMPONENT DIAGNOSIS >

[HALOGEN TYPE]

HEADLAMP CONNECTORS - HALOGEN

Connector No.	M1
Connector Name	WIRE TO WIRE
Connector Color	WHITE

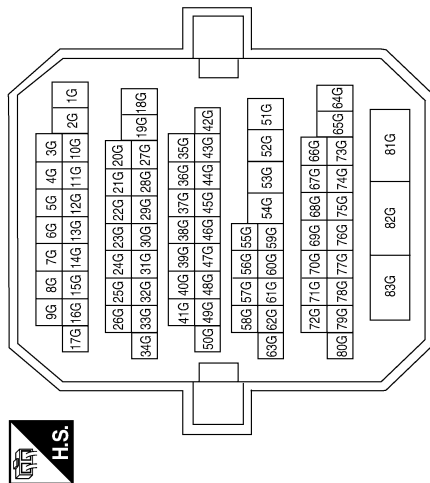

Terminal No.	Color of Wire	Signal Name
8G	P	-
15G	L	-
82G	W/B	-

Connector No.	M3
Connector Name	FUSE BLOCK (J/B)
Connector Color	WHITE

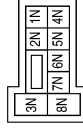

Terminal No.	Color of Wire	Signal Name
1N	W/L	-
7N	Y/R	-

Connector No.	M5
Connector Name	FUSE BLOCK (J/B)
Connector Color	WHITE



Terminal No.	Color of Wire	Signal Name
12M	O	-

Connector No.	M16
Connector Name	BCM (BODY CONTROL MODULE)
Connector Color	BLACK



Terminal No.	Color of Wire	Signal Name
1	W/B	BATT (F/L)

Connector No.	M17
Connector Name	BCM (BODY CONTROL MODULE)
Connector Color	WHITE

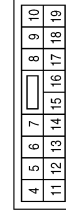

Terminal No.	Color of Wire	Signal Name
11	Y/R	BAT BCM FUSE
13	B	GND1

HEADLAMP

< COMPONENT DIAGNOSIS >

[HALOGEN TYPE]

Connector No.	M24
Connector Name	COMBINATION METER
Connector Color	WHITE



1	2	3	4	5	6	7	8	9	10	11	12	13	14	15	16	17	18	19	20
21	22	23	24	25	26	27	28	29	30	31	32	33	34	35	36	37	38	39	40

Terminal No.	Color of Wire	Signal Name
1	W/L	BAT
2	O	IGN
3	B	GND(POWER)
21	L	CAN-H
22	P	CAN-L
23	B	GND(CIRCUIT)

Connector No.	M19
Connector Name	BCM (BODY CONTROL MODULE)
Connector Color	BLACK



79	78	77	76	75	74	73	72	71	70	69	68	67	66	65	64	63	62	61	60
99	98	97	96	95	94	93	92	91	90	89	88	87	86	85	84	83	82	81	80

Terminal No.	Color of Wire	Signal Name
75	R/Y	INPUT 5
76	R/G	INPUT 3
78	P	CAN-L
79	L	CAN-H
95	R/W	INPUT 1
96	P/B	INPUT 4
97	R/B	INPUT 2

Connector No.	M18
Connector Name	BCM (BODY CONTROL MODULE)
Connector Color	GREEN



39	38	37	36	35	34	33	32	31	30	29	28	27	26	25	24	23	22	21	20
59	58	57	56	55	54	53	52	51	50	49	48	47	46	45	44	43	42	41	40

Terminal No.	Color of Wire	Signal Name
50	LG/B	OUTPUT 5
51	L/W	OUTPUT 1
52	G/B	OUTPUT 2
53	LG/R	OUTPUT 3
54	G/Y	OUTPUT 4

Connector No.	M28
Connector Name	COMBINATION SWITCH
Connector Color	WHITE



1	2	3	4	5	6		
7	8	9	10	11	12	13	14

Terminal No.	Color of Wire	Signal Name
2	G/Y	OUTPUT 4
5	LG/R	OUTPUT 3
7	R/G	INPUT 3
8	LG/B	OUTPUT 5
9	R/B	INPUT 2
10	P/B	INPUT 4
11	R/W	INPUT 1
12	L/W	OUTPUT 1
13	R/Y	INPUT 5
14	G/B	OUTPUT 2

Connector No.	E17
Connector Name	IPDM E/R (INTELLIGENT POWER DISTRIBUTION MODULE ENGINE ROOM)
Connector Color	WHITE



42	41	40	39
46	45	44	43

Terminal No.	Color of Wire	Signal Name
39	P	CAN-L
40	L	CAN-H
41	B	GND (SIGNAL)

ABLIA1713GB

A
B
C
D
E
F
G
H
I
J
K
L
M
N
O
P

EXL

HEADLAMP

< COMPONENT DIAGNOSIS >

[HALOGEN TYPE]

Connector No.	E21
Connector Name	JOINT CONNECTOR-E03
Connector Color	WHITE



Terminal No.	Color of Wire	Signal Name
1	L	-
2	L	-

Terminal No.	Color of Wire	Signal Name
12	B	GND (POWER)

Connector No.	E18
Connector Name	IPDM E/R (INTELLIGENT POWER DISTRIBUTION MODULE ENGINE ROOM)
Connector Color	WHITE

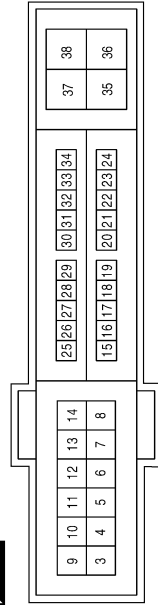

Terminal No.	Color of Wire	Signal Name
8G	P	-
15G	L	-
82G	LG	-

Connector No.	E30
Connector Name	WIRE TO WIRE
Connector Color	WHITE

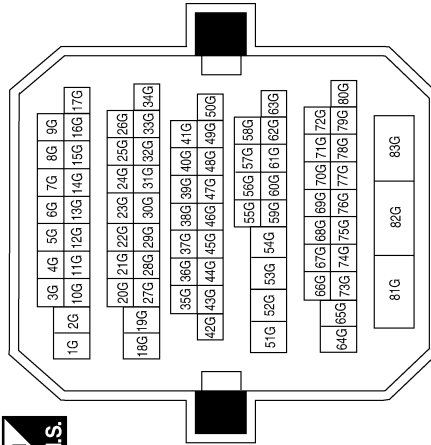

Connector No.	E22
Connector Name	JOINT CONNECTOR-E04
Connector Color	WHITE



Terminal No.	Color of Wire	Signal Name
1	P	-
2	P	-

ABLIA1213GB

HEADLAMP

< COMPONENT DIAGNOSIS >

[HALOGEN TYPE]

Connector No.	E213
Connector Name	FRONT COMBINATION LAMP LH
Connector Color	BLACK



Terminal No.	Color of Wire	Signal Name
3	G	-
4	B	-

Connector No.	E212
Connector Name	FRONT COMBINATION LAMP LH (WITHOUT XENON HEADLAMP SYSTEM)
Connector Color	BLACK



Terminal No.	Color of Wire	Signal Name
1	L	-
2	B	-

Connector No.	E200
Connector Name	IPDM E/R (INTELLIGENT POWER DISTRIBUTION MODULE ENGINE ROOM)
Connector Color	WHITE

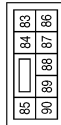

Terminal No.	Color of Wire	Signal Name
83	R/Y	HEADLAMP LO RH
84	L	HEADLAMP LO LH
89	L/W	HEADLAMP HI RH
90	G	HEADLAMP HI LH

Connector No.	E223
Connector Name	FRONT COMBINATION LAMP RH (WITHOUT XENON HEADLAMP SYSTEM)
Connector Color	BLACK



Terminal No.	Color of Wire	Signal Name
1	R/Y	-
2	B	-

Connector No.	E222
Connector Name	FRONT COMBINATION LAMP RH (WITHOUT DAYTIME LIGHT SYSTEM)
Connector Color	BLACK



Terminal No.	Color of Wire	Signal Name
3	L/W	-
4	B	-

ABLIA0487GB

A
B
C
D
E
F
G
H
I
J
K
L
M
N
O
P

EXL

DAYTIME RUNNING LIGHT SYSTEM

< COMPONENT DIAGNOSIS >

[HALOGEN TYPE]

DAYTIME RUNNING LIGHT SYSTEM

Wiring Diagram

INFOID:000000005460983

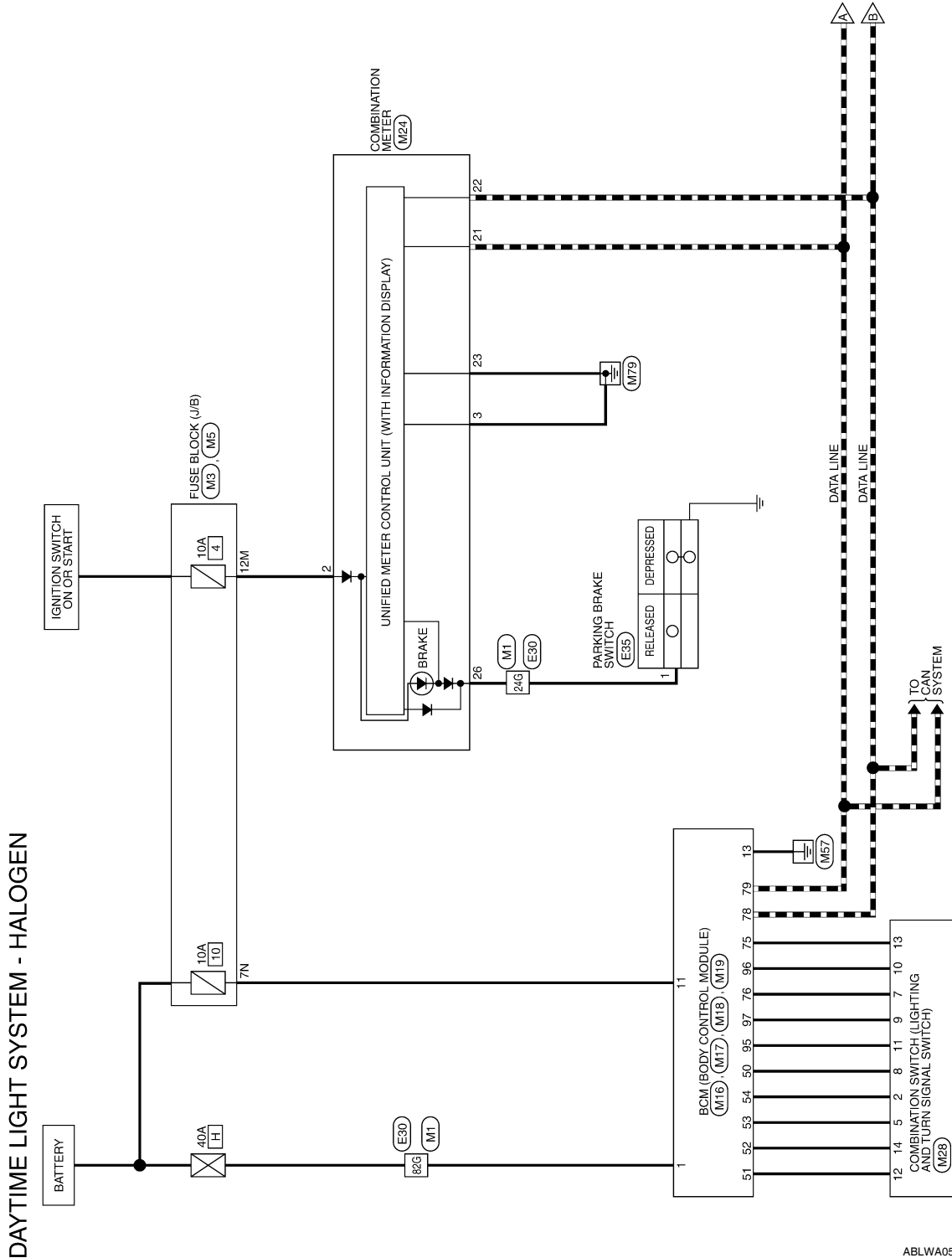

ABLWA0576GE

DAYTIME RUNNING LIGHT SYSTEM

< COMPONENT DIAGNOSIS >

[HALOGEN TYPE]

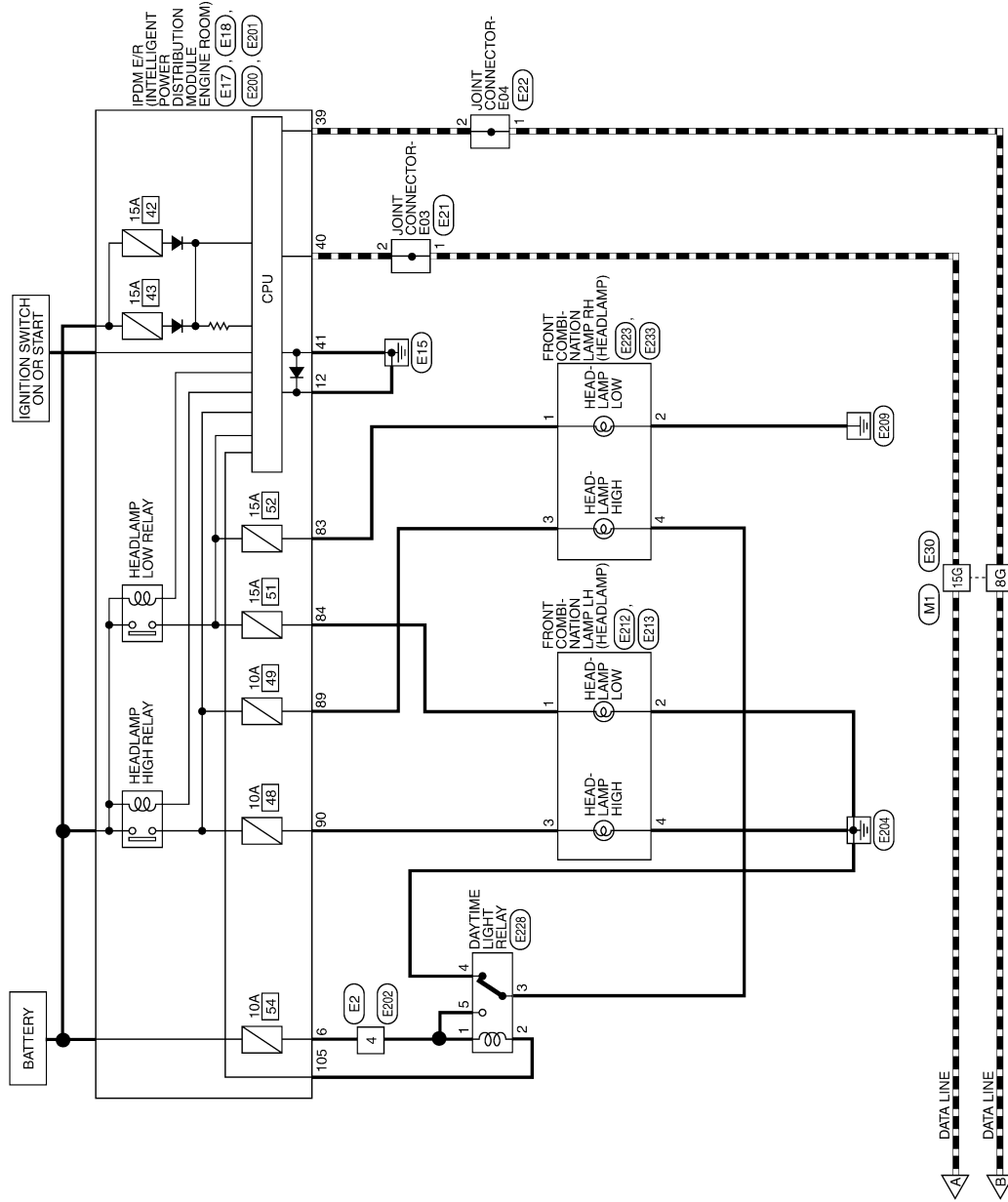

ABLWA0577GE

A
B
C
D
E
F
G
H
I
J
K
EXL
M
N
O
P

DAYTIME RUNNING LIGHT SYSTEM

< COMPONENT DIAGNOSIS >

[HALOGEN TYPE]

DAYTIME LIGHT SYSTEM CONNECTORS - HALOGEN

Connector No.	M1
Connector Name	WIRE TO WIRE
Connector Color	WHITE

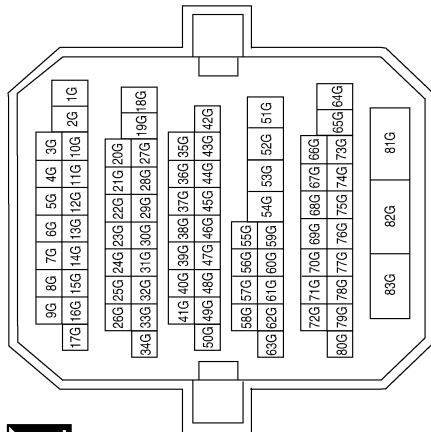

Terminal No.	Color of Wire	Signal Name
8G	P	-
15G	L	-
24G	G/R	-
82G	W/B	-

Connector No.	M3
Connector Name	FUSE BLOCK (J/B)
Connector Color	WHITE

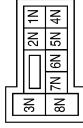

Terminal No.	Color of Wire	Signal Name
7N	Y/R	-

Connector No.	M5
Connector Name	FUSE BLOCK (J/B)
Connector Color	WHITE



Terminal No.	Color of Wire	Signal Name
12M	O	-

Connector No.	M16
Connector Name	BCM (BODY CONTROL MODULE)
Connector Color	BLACK



Terminal No.	Color of Wire	Signal Name
1	W/B	BATT (F/L)

Connector No.	M17
Connector Name	BCM (BODY CONTROL MODULE)
Connector Color	WHITE

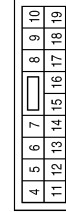

Terminal No.	Color of Wire	Signal Name
11	Y/R	BAT BCM FUSE
13	B	GND1

DAYTIME RUNNING LIGHT SYSTEM

< COMPONENT DIAGNOSIS >

[HALOGEN TYPE]

Connector No.	M24
Connector Name	COMBINATION METER
Connector Color	WHITE

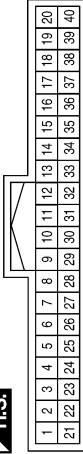
1	2	3	4	5	6	7	8	9	10	11	12	13	14	15	16	17	18	19	20
21	22	23	24	25	26	27	28	29	30	31	32	33	34	35	36	37	38	39	40

Terminal No.	Color of Wire	Signal Name
2	O	IGN
3	B	GND (POWER)
21	L	CAN-H
22	P	CAN-L
23	B	GND (CIRCUIT)
26	G/R	PKB

Connector No.	M19
Connector Name	BCM (BODY CONTROL MODULE)
Connector Color	BLACK

79	78	77	76	75	74	73	72	71	70	69	68	67	66	65	64	63	62	61	60
99	98	97	96	95	94	93	92	91	90	89	88	87	86	85	84	83	82	81	80

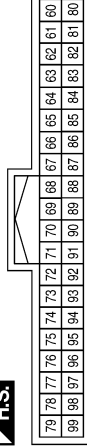
Terminal No.	Color of Wire	Signal Name
75	R/Y	INPUT 5
76	R/G	INPUT 3
78	P	CAN-L
79	L	CAN-H
95	R/W	INPUT 1
96	P/B	INPUT 4
97	R/B	INPUT 2

Connector No.	M18
Connector Name	BCM (BODY CONTROL MODULE)
Connector Color	GREEN

39	38	37	36	35	34	33	32	31	30	29	28	27	26	25	24	23	22	21	20
59	58	57	56	55	54	53	52	51	50	49	48	47	46	45	44	43	42	41	40

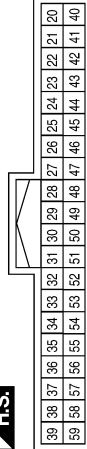
Terminal No.	Color of Wire	Signal Name
50	LG/B	OUTPUT 5
51	L/W	OUTPUT 1
52	G/B	OUTPUT 2
53	LG/R	OUTPUT 3
54	G/Y	OUTPUT 4

Connector No.	E2
Connector Name	WIRE TO WIRE
Connector Color	WHITE



1	2	3		
4	5	6	7	8

Terminal No.	Color of Wire	Signal Name
4	L	-

Terminal No.	Color of Wire	Signal Name
9	R/B	INPUT 2
10	P/B	INPUT 4
11	R/W	INPUT 1
12	L/W	OUTPUT 1
13	R/Y	INPUT 5
14	G/B	OUTPUT 2

Connector No.	M28
Connector Name	COMBINATION SWITCH
Connector Color	WHITE



1	2	3	4	5	6		
7	8	9	10	11	12	13	14

Terminal No.	Color of Wire	Signal Name
2	G/Y	OUTPUT 4
5	LG/R	OUTPUT 3
7	R/G	INPUT 3
8	LG/B	OUTPUT 5

ABLIA1715GB

A
B
C
D
E
F
G
H
I
J
K
L
M
N
O
P

EXL

DAYTIME RUNNING LIGHT SYSTEM

< COMPONENT DIAGNOSIS >

[HALOGEN TYPE]

Terminal No.	Color of Wire	Signal Name
6	L	DTRL
12	B	GND (POWER)

Connector No.	E18
Connector Name	IPDM E/R (INTELLIGENT POWER DISTRIBUTION MODULE ENGINE ROOM)
Connector Color	WHITE

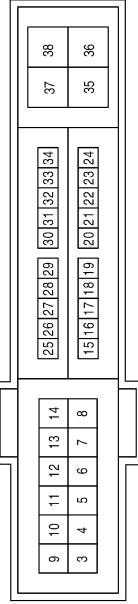

Connector No.	E17
Connector Name	IPDM E/R (INTELLIGENT POWER DISTRIBUTION MODULE ENGINE ROOM)
Connector Color	WHITE



Terminal No.	Color of Wire	Signal Name
39	P	CAN-L
40	L	CAN-H
41	B	GND (SIGNAL)

Connector No.	E22
Connector Name	JOINT CONNECTOR-E04
Connector Color	WHITE



Terminal No.	Color of Wire	Signal Name
1	P	-
2	P	-

Connector No.	E21
Connector Name	JOINT CONNECTOR-E03
Connector Color	WHITE



Terminal No.	Color of Wire	Signal Name
1	L	-
2	L	-

ABLIA1716GB

DAYTIME RUNNING LIGHT SYSTEM

< COMPONENT DIAGNOSIS >

[HALOGEN TYPE]

Connector No.	E35
Connector Name	PARKING BRAKE SWITCH
Connector Color	BLACK



Terminal No.	1	Color of Wire	P	Signal Name	-
--------------	---	---------------	---	-------------	---

Terminal No.	Color of Wire	Signal Name
8G	P	-
15G	L	-
24G	P	-
82G	LG	-

Connector No.	E30
Connector Name	WIRE TO WIRE
Connector Color	WHITE

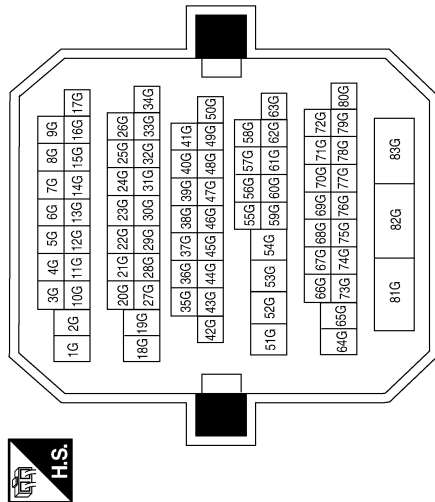

Connector No.	E202
Connector Name	WIRE TO WIRE
Connector Color	WHITE

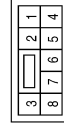

Terminal No.	4	Color of Wire	SB	Signal Name	-
--------------	---	---------------	----	-------------	---

Connector No.	E201
Connector Name	IPDM E/R (INTELLIGENT POWER DISTRIBUTION MODULE ENGINE ROOM)
Connector Color	WHITE

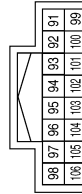

Terminal No.	105	Color of Wire	V	Signal Name	DTRL RLY
--------------	-----	---------------	---	-------------	----------

Connector No.	E200
Connector Name	IPDM E/R (INTELLIGENT POWER DISTRIBUTION MODULE ENGINE ROOM)
Connector Color	WHITE

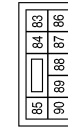

Terminal No.	Color of Wire	Signal Name
83	R/Y	HEADLAMP LO RH
84	L	HEADLAMP LO LH
89	L/W	HEADLAMP HI RH
90	G	HEADLAMP HI LH

ABLIA1717GB

A
B
C
D
E
F
G
H
I
J
K
L
M
N
O
P

EXL

DAYTIME RUNNING LIGHT SYSTEM

< COMPONENT DIAGNOSIS >

[HALOGEN TYPE]

Connector No.	E223
Connector Name	FRONT COMBINATION LAMP RH (WITHOUT XENON HEADLAMP SYSTEM)
Connector Color	BLACK



Terminal No.	Color of Wire	Signal Name
1	R/Y	-
2	B	-

Connector No.	E213
Connector Name	FRONT COMBINATION LAMP LH
Connector Color	BLACK



Terminal No.	Color of Wire	Signal Name
3	G	-
4	B	-

Connector No.	E212
Connector Name	FRONT COMBINATION LAMP LH (WITHOUT XENON HEADLAMP SYSTEM)
Connector Color	BLACK



Terminal No.	Color of Wire	Signal Name
1	L	-
2	B	-

Connector No.	E233
Connector Name	FRONT COMBINATION LAMP RH (WITH DAYTIME LIGHT SYSTEM)
Connector Color	BLACK



Terminal No.	Color of Wire	Signal Name
3	LW	-
4	GR/R	-

Connector No.	E228
Connector Name	DAYTIME LIGHT RELAY
Connector Color	BLACK



Terminal No.	Color of Wire	Signal Name
1	SB	-
2	V	-
3	GR/R	-
4	B	-
5	SB	-

ABLIA1718GB

AUTO LIGHT SYSTEM

< COMPONENT DIAGNOSIS >

[HALOGEN TYPE]

AUTO LIGHT SYSTEM

Wiring Diagram

INFOID:000000005530279

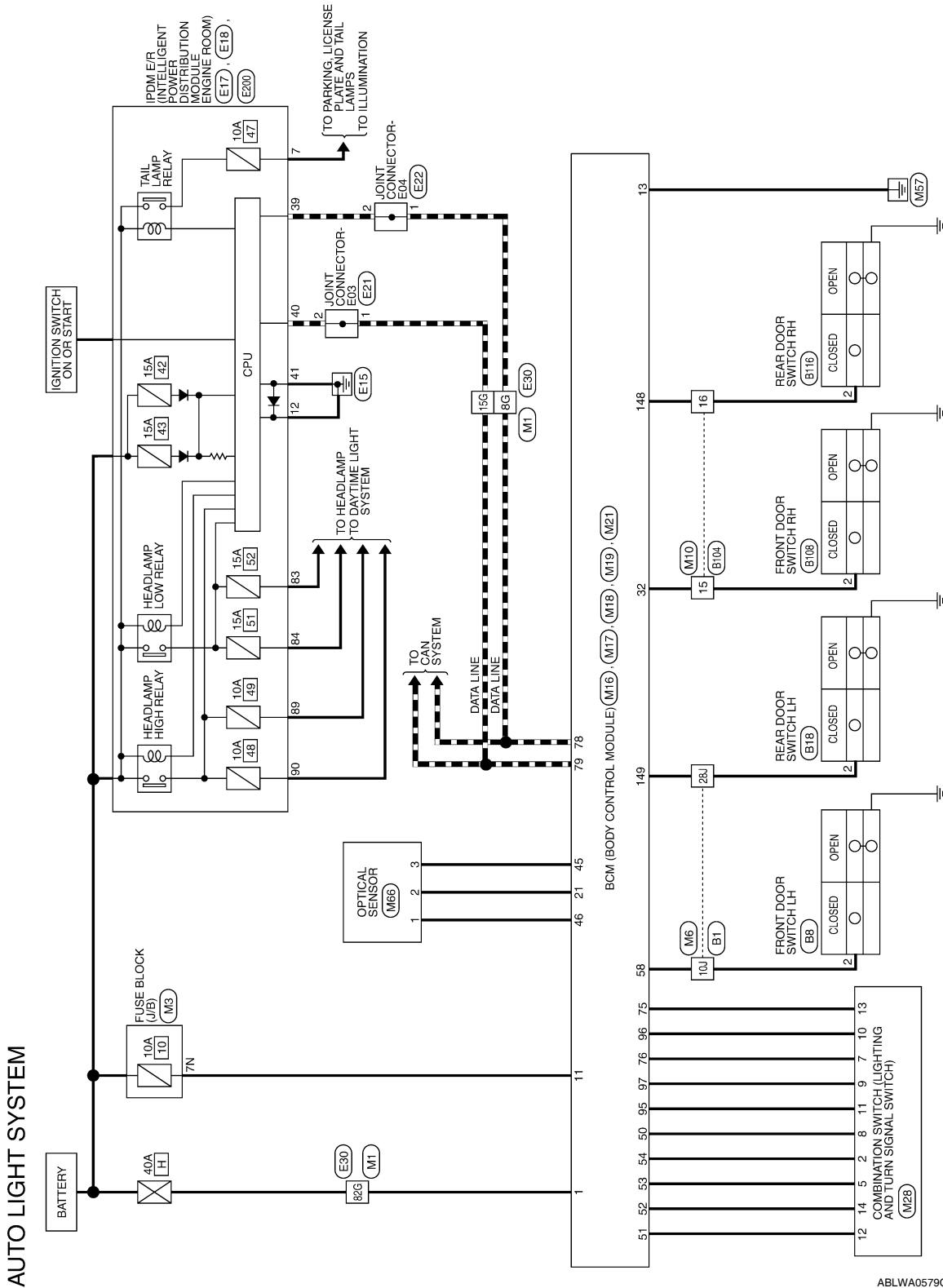

ABLWA0579GE

A
B
C
D
E
F
G
H
I
J
K
EXL
M
N
O
P

AUTO LIGHT SYSTEM CONNECTORS

Connector No.	M1
Connector Name	WIRE TO WIRE
Connector Color	WHITE

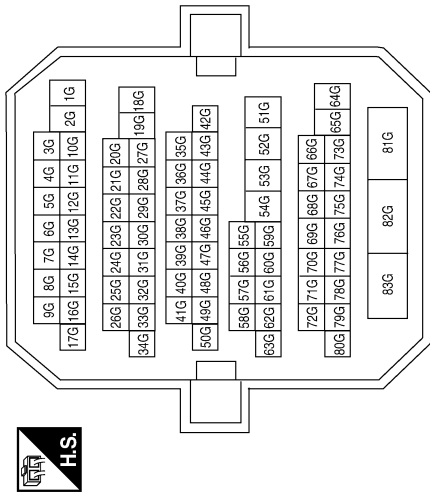

Terminal No.	Color of Wire	Signal Name
8G	P	-
15G	L	-
82G	W/B	-

Connector No.	M10
Connector Name	WIRE TO WIRE
Connector Color	WHITE

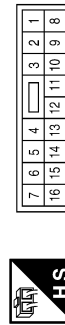

Terminal No.	Color of Wire	Signal Name
15	R/B	-
16	R/W	-

Connector No.	M3
Connector Name	FUSE BLOCK (J/B)
Connector Color	WHITE

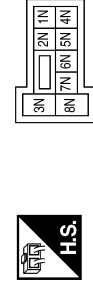

Terminal No.	Color of Wire	Signal Name
7N	Y/R	-

Connector No.	M6
Connector Name	WIRE TO WIRE
Connector Color	WHITE

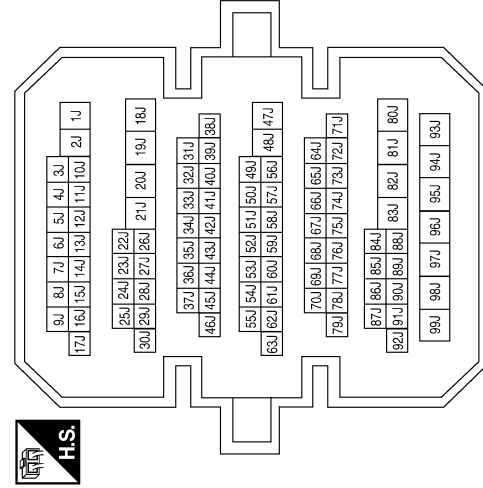

Terminal No.	Color of Wire	Signal Name
10J	SB	-
28J	R/B	-

Connector No.	M17
Connector Name	BCM (BODY CONTROL MODULE)
Connector Color	WHITE

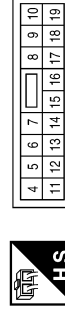

Terminal No.	Color of Wire	Signal Name
11	Y/R	BAT BCM FUSE
13	B	GND1

Connector No.	M16
Connector Name	BCM (BODY CONTROL MODULE)
Connector Color	BLACK



Terminal No.	Color of Wire	Signal Name
1	W/B	BATT (F/L)

AUTO LIGHT SYSTEM

< COMPONENT DIAGNOSIS >

[HALOGEN TYPE]

Connector No.	M18
Connector Name	BCM (BODY CONTROL MODULE)
Connector Color	GREEN



39	38	37	36	35	34	33	32	31	30	29	28	27	26	25	24	23	22	21	20
59	58	57	56	55	54	53	52	51	50	49	48	47	46	45	44	43	42	41	40

Terminal No.	Color of Wire	Signal Name
21	P/B	A/L SIGNAL TYPE 1
32	R/B	AS DOOR SW 1
45	P	GND RF2 A/L
46	V/W	A/L POWER SUPPLY 5V
50	LG/B	OUTPUT 5
51	L/W	OUTPUT 1
52	G/B	OUTPUT 2
53	LG/R	OUTPUT 3
54	G/Y	OUTPUT 4
58	SB	DR DOOR SW

Connector No.	M19
Connector Name	BCM (BODY CONTROL MODULE)
Connector Color	BLACK



79	78	77	76	75	74	73	72	71	70	69	68	67	66	65	64	63	62	61	60
99	98	97	96	95	94	93	92	91	90	89	88	87	86	85	84	83	82	81	80

Terminal No.	Color of Wire	Signal Name
75	R/Y	INPUT 5
76	R/G	INPUT 3
78	P	CAN-L
79	L	CAN-H
95	R/W	INPUT 1
96	P/B	INPUT 4
97	R/B	INPUT 2

Connector No.	M21
Connector Name	BCM (BODY CONTROL MODULE)
Connector Color	GRAY



131	130	129	128	127	126	125	124	123	122	121	120	119	118	117	116	115	114	113	112
151	150	149	148	147	146	145	144	143	142	141	140	139	138	137	136	135	134	133	132

Connector No.	M28
Connector Name	COMBINATION SWITCH
Connector Color	WHITE



1	2	3	4	5	6
7	8	9	10	11	12
13	14				

Terminal No.	Color of Wire	Signal Name
2	G/Y	OUTPUT 4
5	LG/R	OUTPUT 3
7	R/G	INPUT 3
8	LG/B	OUTPUT 5
9	R/B	INPUT 2
10	P/B	INPUT 4
11	R/W	INPUT 1
12	L/W	OUTPUT 1
13	R/Y	INPUT 5
14	G/B	OUTPUT 2

Terminal No.	Color of Wire	Signal Name
148	R/W	RR DOOR SW
149	R/B	RL DOOR SW

ABLIA1725GB

A B C D E F G H I J K EXL M N O P

AUTO LIGHT SYSTEM

< COMPONENT DIAGNOSIS >

[HALOGEN TYPE]

Connector No.	M66
Connector Name	OPTICAL SENSOR
Connector Color	WHITE



Terminal No.	Color of Wire	Signal Name
1	V/W	POWER
2	P/B	OUTPUT
3	P	GND

Connector No.	E17
Connector Name	IPDM E/R (INTELLIGENT POWER DISTRIBUTION MODULE ENGINE ROOM)
Connector Color	WHITE



Terminal No.	Color of Wire	Signal Name
39	P	CAN-L
40	L	CAN-H
41	B	GND (SIGNAL)

Connector No.	E18
Connector Name	IPDM E/R (INTELLIGENT POWER DISTRIBUTION MODULE ENGINE ROOM)
Connector Color	WHITE

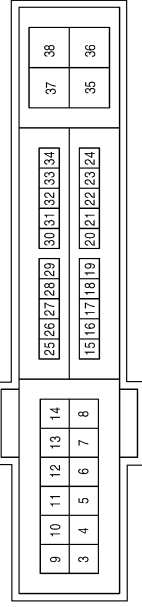

Terminal No.	Color of Wire	Signal Name
7	GR	TAIL/ILLUMI
12	B	GND (POWER)

Connector No.	E21
Connector Name	JOINT CONNECTOR-E03
Connector Color	WHITE

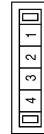

Terminal No.	Color of Wire	Signal Name
1	L	-
2	L	-

Connector No.	E22
Connector Name	JOINT CONNECTOR-E04
Connector Color	WHITE



Terminal No.	Color of Wire	Signal Name
1	P	-
2	P	-

AUTO LIGHT SYSTEM

< COMPONENT DIAGNOSIS >

[HALOGEN TYPE]

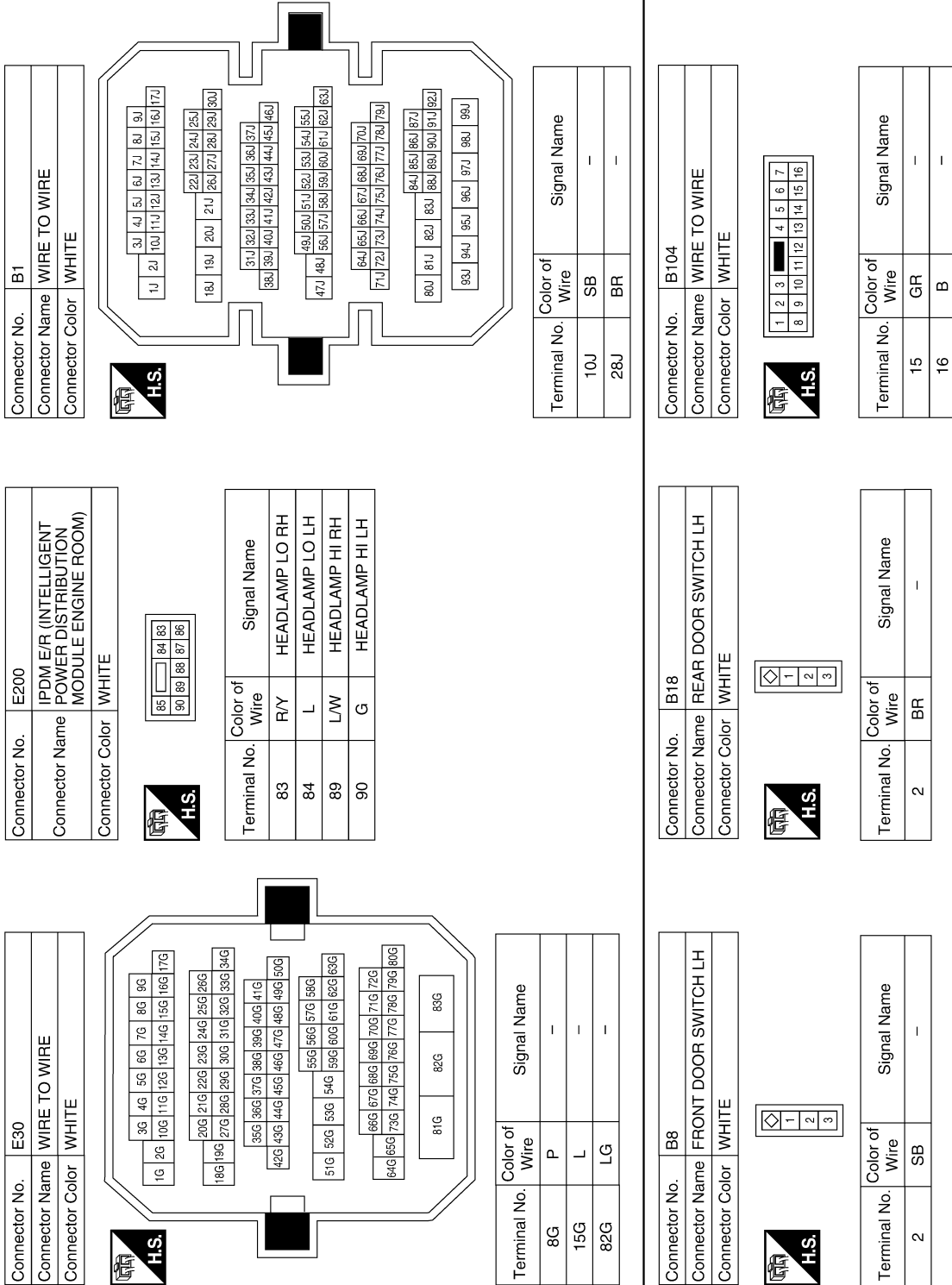

A B C D E F G H I J K M N O P

EXL

ABLIA0509GB

AUTO LIGHT SYSTEM

< COMPONENT DIAGNOSIS >

[HALOGEN TYPE]

Connector No.	B116	
Connector Name	REAR DOOR SWITCH RH	
Connector Color	WHITE	



◇	1	2	3
---	---	---	---

Terminal No.	Color of Wire	Signal Name
2	B	-

Connector No.	B108	
Connector Name	FRONT DOOR SWITCH RH	
Connector Color	WHITE	



◇	1	2	3
---	---	---	---

Terminal No.	Color of Wire	Signal Name
2	GR	-

ABLIA0510GB

FRONT FOG LAMP SYSTEM

< COMPONENT DIAGNOSIS >

[HALOGEN TYPE]

FRONT FOG LAMP SYSTEM

Wiring Diagram

INFOID:000000005530280

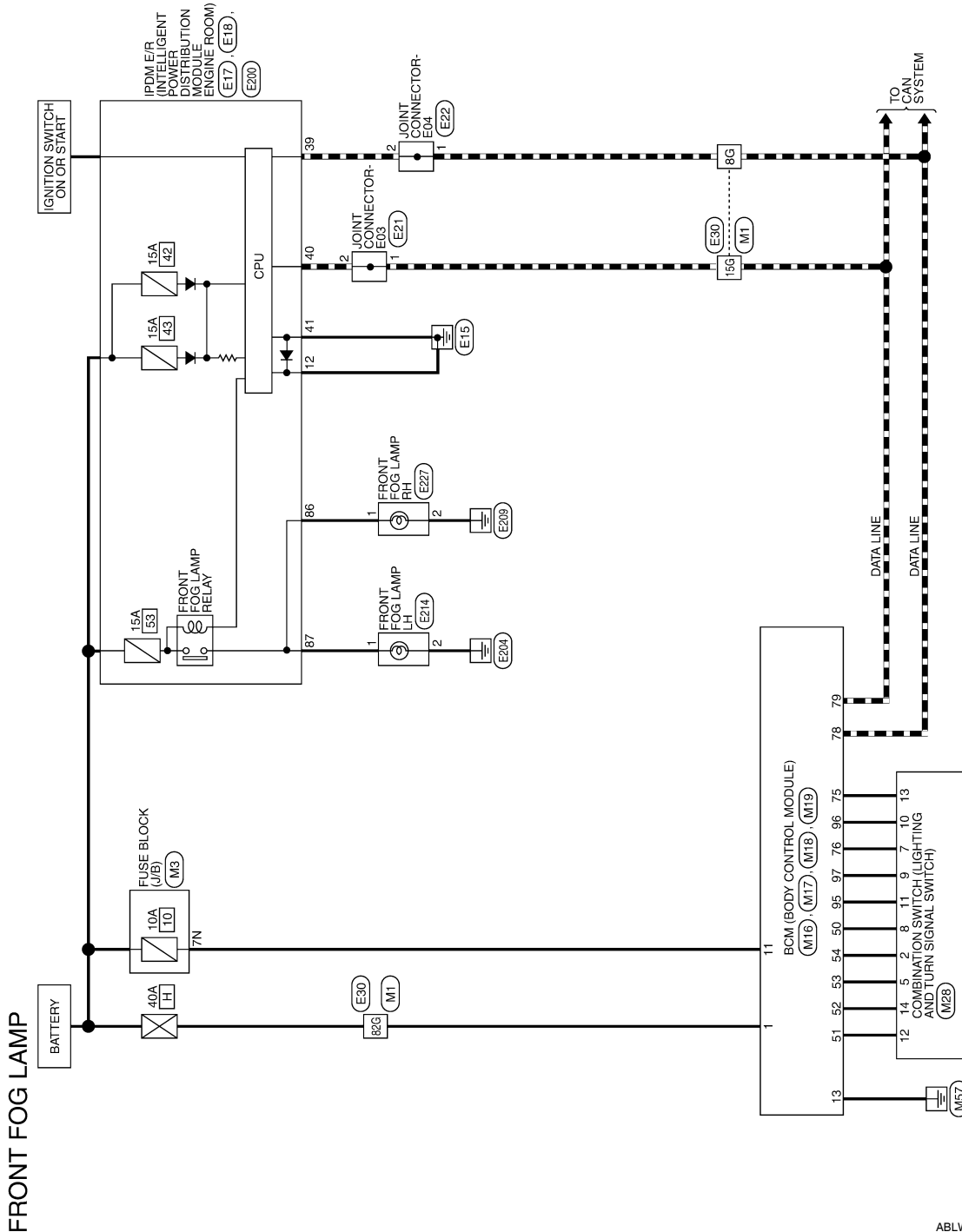

A
B
C
D
E
F
G
H
I
J
K
EXL
M
N
O
P

ABLWA0582GE

FRONT FOG LAMP SYSTEM

< COMPONENT DIAGNOSIS >

[HALOGEN TYPE]

FRONT FOG LAMP CONNECTORS

Connector No.	M1
Connector Name	WIRE TO WIRE
Connector Color	WHITE

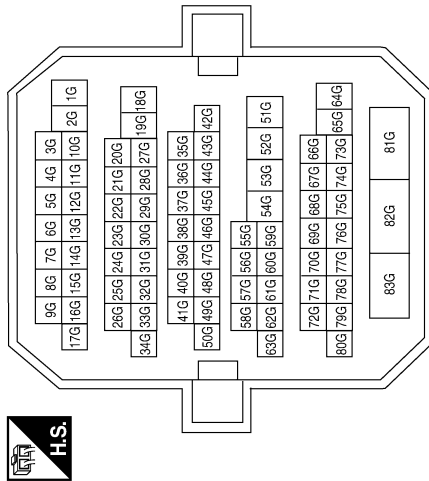

Terminal No.	Color of Wire	Signal Name
8G	P	-
15G	L	-
82G	W/B	-

Connector No.	M3
Connector Name	FUSE BLOCK (J/B)
Connector Color	WHITE

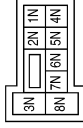

Terminal No.	Color of Wire	Signal Name
7N	Y/R	-

Connector No.	M16
Connector Name	BCM (BODY CONTROL MODULE)
Connector Color	BLACK



Terminal No.	Color of Wire	Signal Name
1	W/B	BATT (F/L)

Connector No.	M17
Connector Name	BCM (BODY CONTROL MODULE)
Connector Color	WHITE

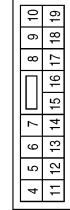

Terminal No.	Color of Wire	Signal Name
11	Y/R	BAT BCM FUSE
13	B	GND1

Connector No.	M18
Connector Name	BCM (BODY CONTROL MODULE)
Connector Color	GREEN

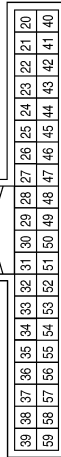

Terminal No.	Color of Wire	Signal Name
50	LG/B	OUTPUT 5
51	L/W	OUTPUT 1
52	G/B	OUTPUT 2
53	LG/R	OUTPUT 3
54	G/Y	OUTPUT 4

FRONT FOG LAMP SYSTEM

< COMPONENT DIAGNOSIS >

[HALOGEN TYPE]

Connector No.	E17
Connector Name	IPDM E/R (INTELLIGENT POWER DISTRIBUTION MODULE ENGINE ROOM)
Connector Color	WHITE

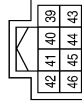

Terminal No.	Color of Wire	Signal Name
39	P	CAN-L
40	L	CAN-H
41	B	GND (SIGNAL)

Connector No.	M28
Connector Name	COMBINATION SWITCH
Connector Color	WHITE

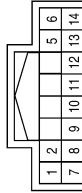

Terminal No.	Color of Wire	Signal Name
2	G/Y	OUTPUT 4
5	LG/R	OUTPUT 3
7	R/G	INPUT 3
8	LG/B	OUTPUT 5
9	R/B	INPUT 2
10	P/B	INPUT 4
11	R/W	INPUT 1
12	L/W	OUTPUT 1
13	R/Y	INPUT 5
14	G/B	OUTPUT 2

Connector No.	M19
Connector Name	BCM (BODY CONTROL MODULE)
Connector Color	BLACK

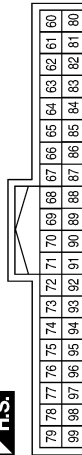

Terminal No.	Color of Wire	Signal Name
75	R/Y	INPUT 5
76	R/G	INPUT 3
78	P	CAN-L
79	L	CAN-H
95	R/W	INPUT 1
96	P/B	INPUT 4
97	R/B	INPUT 2

Connector No.	E21
Connector Name	JOINT CONNECTOR-E03
Connector Color	WHITE



Terminal No.	Color of Wire	Signal Name
1	L	-
2	L	-

Terminal No.	12
Color of Wire	B
Signal Name	GND (POWER)

Connector No.	E18
Connector Name	IPDM E/R (INTELLIGENT POWER DISTRIBUTION MODULE ENGINE ROOM)
Connector Color	WHITE

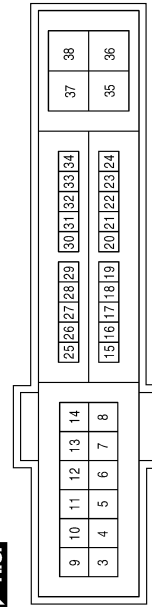

ABLIA1195GB

A
B
C
D
E
F
G
H
I
J
K
EXL
M
N
O
P

FRONT FOG LAMP SYSTEM

< COMPONENT DIAGNOSIS >

[HALOGEN TYPE]

Terminal No.	Color of Wire	Signal Name
8G	P	-
15G	L	-
82G	LG	-

Connector No.	E30
Connector Name	WIRE TO WIRE
Connector Color	WHITE

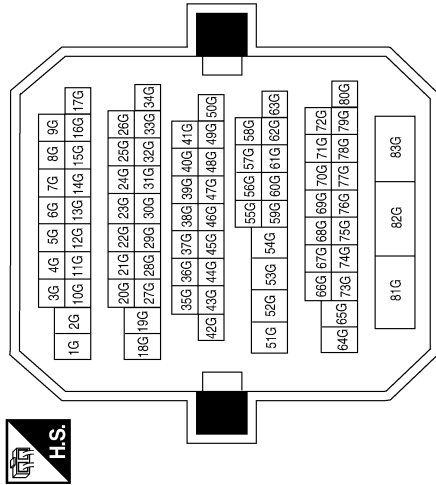

Connector No.	E22
Connector Name	JOINT CONNECTOR-E04
Connector Color	WHITE



Terminal No.	Color of Wire	Signal Name
1	P	-
2	P	-

Connector No.	E227
Connector Name	FRONT FOG LAMP RH
Connector Color	BLACK



Terminal No.	Color of Wire	Signal Name
1	W/R	-
2	B	-

Connector No.	E214
Connector Name	FRONT FOG LAMP LH
Connector Color	BLACK



Terminal No.	Color of Wire	Signal Name
1	L/Y	-
2	B	-

Connector No.	E200
Connector Name	IPDM E/R (INTELLIGENT POWER DISTRIBUTION MODULE ENGINE ROOM)
Connector Color	WHITE



Terminal No.	Color of Wire	Signal Name
86	W/R	FR FOG LAMP RH
87	L/Y	FR FOG LAMP LH

ABLIA0513GB

TURN SIGNAL AND HAZARD WARNING LAMP SYSTEM

< COMPONENT DIAGNOSIS >

[HALOGEN TYPE]

TURN SIGNAL AND HAZARD WARNING LAMP SYSTEM

Wiring Diagram

INFOID:000000005530281

TM: WITH TURN SIGNAL IN MIRROR

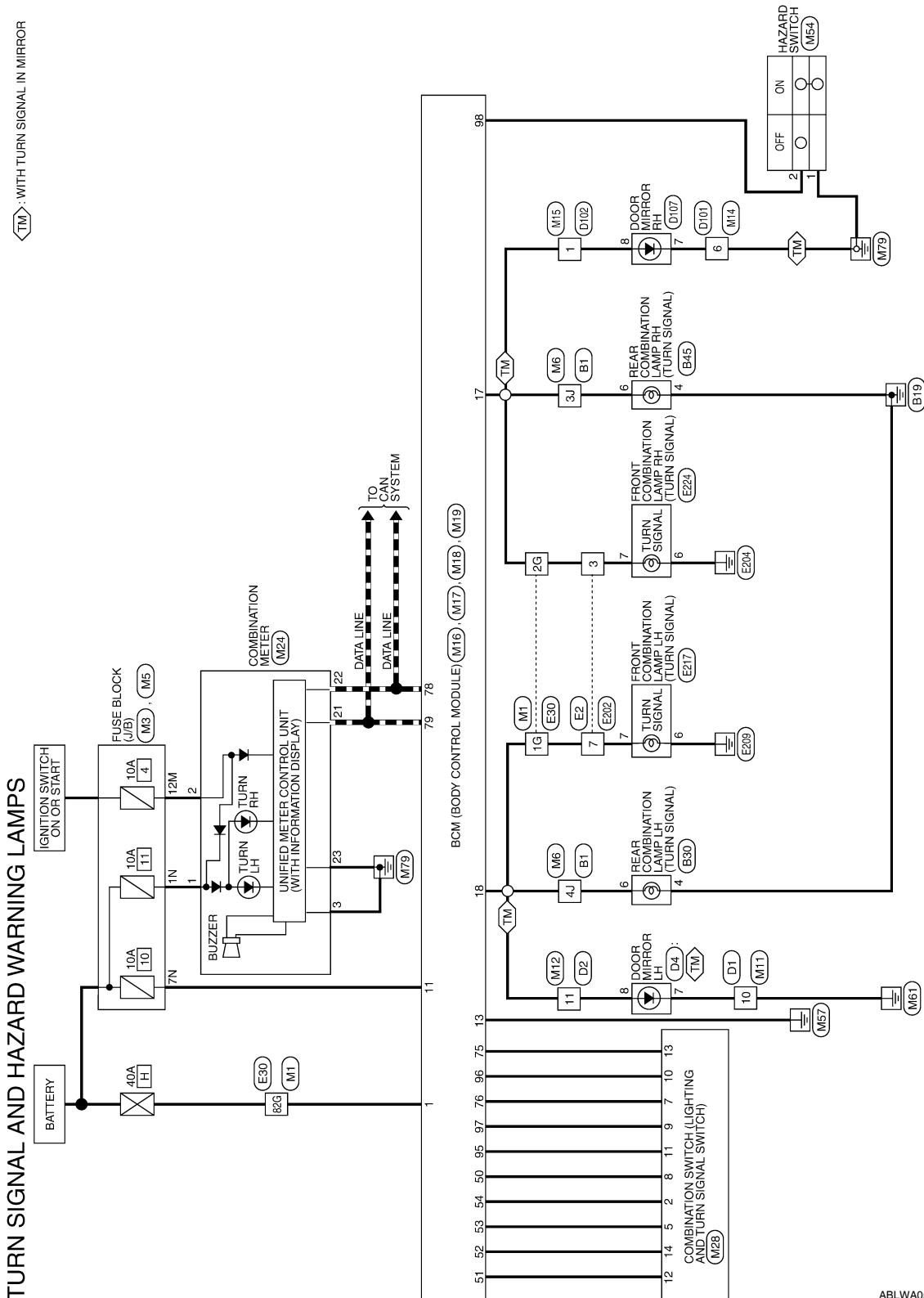

ABLWA0578GE

A
B
C
D
E
F
G
H
I
J
K
EXL
M
N
O
P

TURN SIGNAL AND HAZARD WARNING LAMP SYSTEM

< COMPONENT DIAGNOSIS >

[HALOGEN TYPE]

TURN SIGNAL AND HAZARD WARNING LAMPS CONNECTORS

Connector No.	M1
Connector Name	WIRE TO WIRE
Connector Color	WHITE

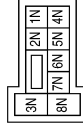
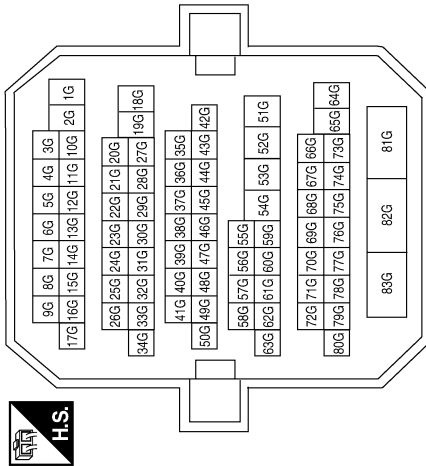

Connector No.	M3
Connector Name	FUSE BLOCK (J/B)
Connector Color	WHITE

Terminal No.	Color of Wire	Signal Name
1N	W/L	-
7N	Y/R	-

Connector No.	M5
Connector Name	FUSE BLOCK (J/B)
Connector Color	WHITE

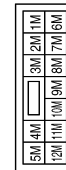

Terminal No.	Color of Wire	Signal Name
12M	O	-

ABLIA0514GB

TURN SIGNAL AND HAZARD WARNING LAMP SYSTEM

< COMPONENT DIAGNOSIS >

[HALOGEN TYPE]

Connector No.	M11
Connector Name	WIRE TO WIRE
Connector Color	WHITE

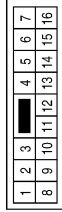

Terminal No.	10	Color of Wire	B	Signal Name	-
--------------	----	---------------	---	-------------	---

Terminal No.	3J	Color of Wire	G/B	Signal Name	-
	4J		G/Y		-

Connector No.	M6
Connector Name	WIRE TO WIRE
Connector Color	WHITE

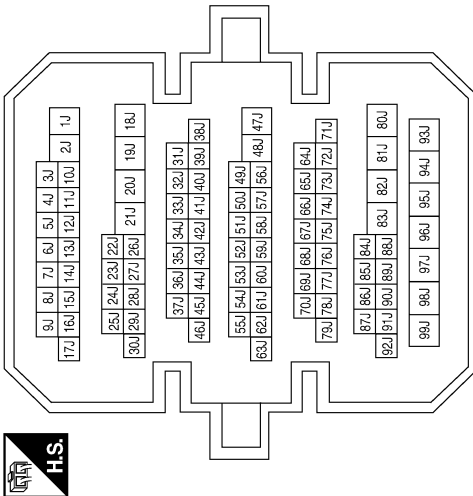

Connector No.	M15
Connector Name	WIRE TO WIRE
Connector Color	WHITE

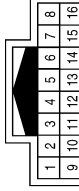

Terminal No.	1	Color of Wire	G/B	Signal Name	-
--------------	---	---------------	-----	-------------	---

Connector No.	M14
Connector Name	WIRE TO WIRE
Connector Color	WHITE

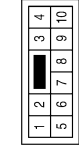

Terminal No.	6	Color of Wire	B	Signal Name	-
--------------	---	---------------	---	-------------	---

Connector No.	M12
Connector Name	WIRE TO WIRE
Connector Color	WHITE

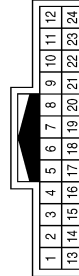

Terminal No.	11	Color of Wire	G/Y	Signal Name	-
--------------	----	---------------	-----	-------------	---

A
B
C
D
E
F
G
H
I
J
K
L
M
N
O
P

EXL

TURN SIGNAL AND HAZARD WARNING LAMP SYSTEM

< COMPONENT DIAGNOSIS >

[HALOGEN TYPE]

Connector No.	M18
Connector Name	BCM (BODY CONTROL MODULE)
Connector Color	GREEN



39	38	37	36	35	34	33	32	31	30	29	28	27	26	25	24	23	22	21	20
59	58	57	56	55	54	53	52	51	50	49	48	47	46	45	44	43	42	41	40

Terminal No.	Color of Wire	Signal Name
50	LG/B	OUTPUT 5
51	L/W	OUTPUT 1
52	G/B	OUTPUT 2
53	LG/R	OUTPUT 3
54	G/Y	OUTPUT 4

Connector No.	M17
Connector Name	BCM (BODY CONTROL MODULE)
Connector Color	WHITE



4	5	6	7	8	9	10		
11	12	13	14	15	16	17	18	19

Terminal No.	Color of Wire	Signal Name
11	Y/R	BAT BCM FUSE
13	B	GND1
17	G/B	FR FLASHER
18	G/Y	FL FLASHER

Connector No.	M16
Connector Name	BCM (BODY CONTROL MODULE)
Connector Color	BLACK



1	3
2	

Terminal No.	Color of Wire	Signal Name
1	W/B	BATT (F/L)

Connector No.	M24
Connector Name	COMBINATION METER
Connector Color	WHITE



1	2	3	4	5	6	7	8	9	10	11	12	13	14	15	16	17	18	19	20
21	22	23	24	25	26	27	28	29	30	31	32	33	34	35	36	37	38	39	40

Terminal No.	Color of Wire	Signal Name
1	W/L	BAT
2	O	IGN
3	B	GND (POWER)
21	L	CAN-H
22	P	CAN-L
23	B	GND (CIRCUIT)

Terminal No.	Color of Wire	Signal Name
75	R/Y	INPUT 5
76	R/G	INPUT 3
78	P	CAN-L
79	L	CAN-H
95	R/W	INPUT 1
96	P/B	INPUT 4
97	R/B	INPUT 2
98	G/O	HAZARD SW

Connector No.	M19
Connector Name	BCM (BODY CONTROL MODULE)
Connector Color	BLACK



79	78	77	76	75	74	73	72	71	70	69	68	67	66	65	64	63	62	61	60
99	98	97	96	95	94	93	92	91	90	89	88	87	86	85	84	83	82	81	80

ABLIA1719GB

TURN SIGNAL AND HAZARD WARNING LAMP SYSTEM

< COMPONENT DIAGNOSIS >

[HALOGEN TYPE]

Connector No.	M28
Connector Name	COMBINATION SWITCH
Connector Color	WHITE

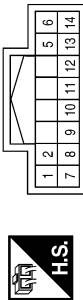

Terminal No.	Color of Wire	Signal Name
2	G/Y	OUTPUT 4
5	LG/R	OUTPUT 3
7	R/G	INPUT 3
8	LG/B	OUTPUT 5
9	R/B	INPUT 2
10	P/B	INPUT 4
11	R/W	INPUT 1
12	L/W	OUTPUT 1
13	R/Y	INPUT 5
14	G/B	OUTPUT 2

Connector No.	M54
Connector Name	HAZARD SWITCH
Connector Color	WHITE

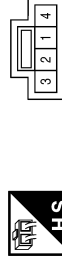

Terminal No.	Color of Wire	Signal Name
1	B	-
2	G/O	-

Connector No.	E2
Connector Name	WIRE TO WIRE
Connector Color	WHITE



Terminal No.	Color of Wire	Signal Name
3	SB	-
7	Y	-

Connector No.	E30
Connector Name	WIRE TO WIRE
Connector Color	WHITE

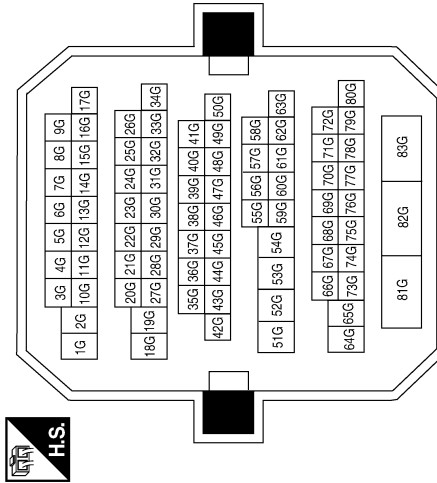

Terminal No.	Color of Wire	Signal Name
1G	Y	-
2G	SB	-
82G	LG	-

ABLIA1197GB

A
B
C
D
E
F
G
H
I
J
K
L
M
N
O
P

EXL

TURN SIGNAL AND HAZARD WARNING LAMP SYSTEM

< COMPONENT DIAGNOSIS >

[HALOGEN TYPE]

Connector No.	E202
Connector Name	WIRE TO WIRE
Connector Color	WHITE

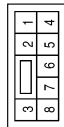

Terminal No.	Color of Wire	Signal Name
3	G/B	-
7	G/Y	-

Connector No.	E217
Connector Name	FRONT COMBINATION LAMP LH
Connector Color	GRAY



Terminal No.	Color of Wire	Signal Name
6	B	-
7	G/Y	-

Connector No.	E224
Connector Name	FRONT COMBINATION LAMP RH
Connector Color	GRAY



Terminal No.	Color of Wire	Signal Name
6	B	-
7	G/B	-

Connector No.	B1
Connector Name	WIRE TO WIRE
Connector Color	WHITE

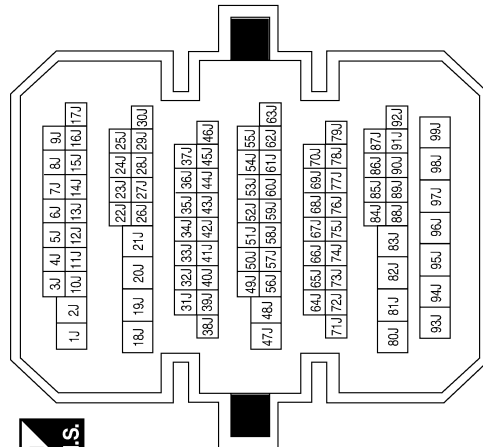

Connector No.	B30
Connector Name	REAR COMBINATION LAMP LH
Connector Color	WHITE



Terminal No.	Color of Wire	Signal Name
4	B	-
6	LG	-

TURN SIGNAL AND HAZARD WARNING LAMP SYSTEM

< COMPONENT DIAGNOSIS >

[HALOGEN TYPE]

Connector No.	D2
Connector Name	WIRE TO WIRE
Connector Color	WHITE

Terminal No.	Color of Wire	Signal Name
11	GR	-

Connector No.	D1
Connector Name	WIRE TO WIRE
Connector Color	WHITE

Terminal No.	Color of Wire	Signal Name
10	B	-

Connector No.	B45
Connector Name	REAR COMBINATION LAMP RH
Connector Color	WHITE

Terminal No.	Color of Wire	Signal Name
4	B	-
6	BR	-

Connector No.	D102
Connector Name	WIRE TO WIRE
Connector Color	WHITE

Terminal No.	Color of Wire	Signal Name
1	W	-

Connector No.	D101
Connector Name	WIRE TO WIRE
Connector Color	WHITE

Terminal No.	Color of Wire	Signal Name
6	B	-

Connector No.	D4
Connector Name	DOOR MIRROR LH
Connector Color	WHITE

Terminal No.	Color of Wire	Signal Name
7	B	TURN(-)
8	GR	TURN(+)

ABLIA0519GB

A
B
C
D
E
F
G
H
I
J
K
L
M
N
O
P

EXL

TURN SIGNAL AND HAZARD WARNING LAMP SYSTEM

< COMPONENT DIAGNOSIS >

[HALOGEN TYPE]

Connector No.	D107
Connector Name	DOOR MIRROR RH
Connector Color	WHITE

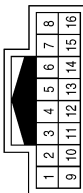

Terminal No.	Color of Wire	Signal Name
7	B	TURN(-)
8	W	TURN(+)

ABLIA0520GB

PARKING, LICENSE PLATE AND TAIL LAMPS SYSTEM

< COMPONENT DIAGNOSIS >

[HALOGEN TYPE]

PARKING, LICENSE PLATE AND TAIL LAMPS SYSTEM

Wiring Diagram

INFOID:000000005530282

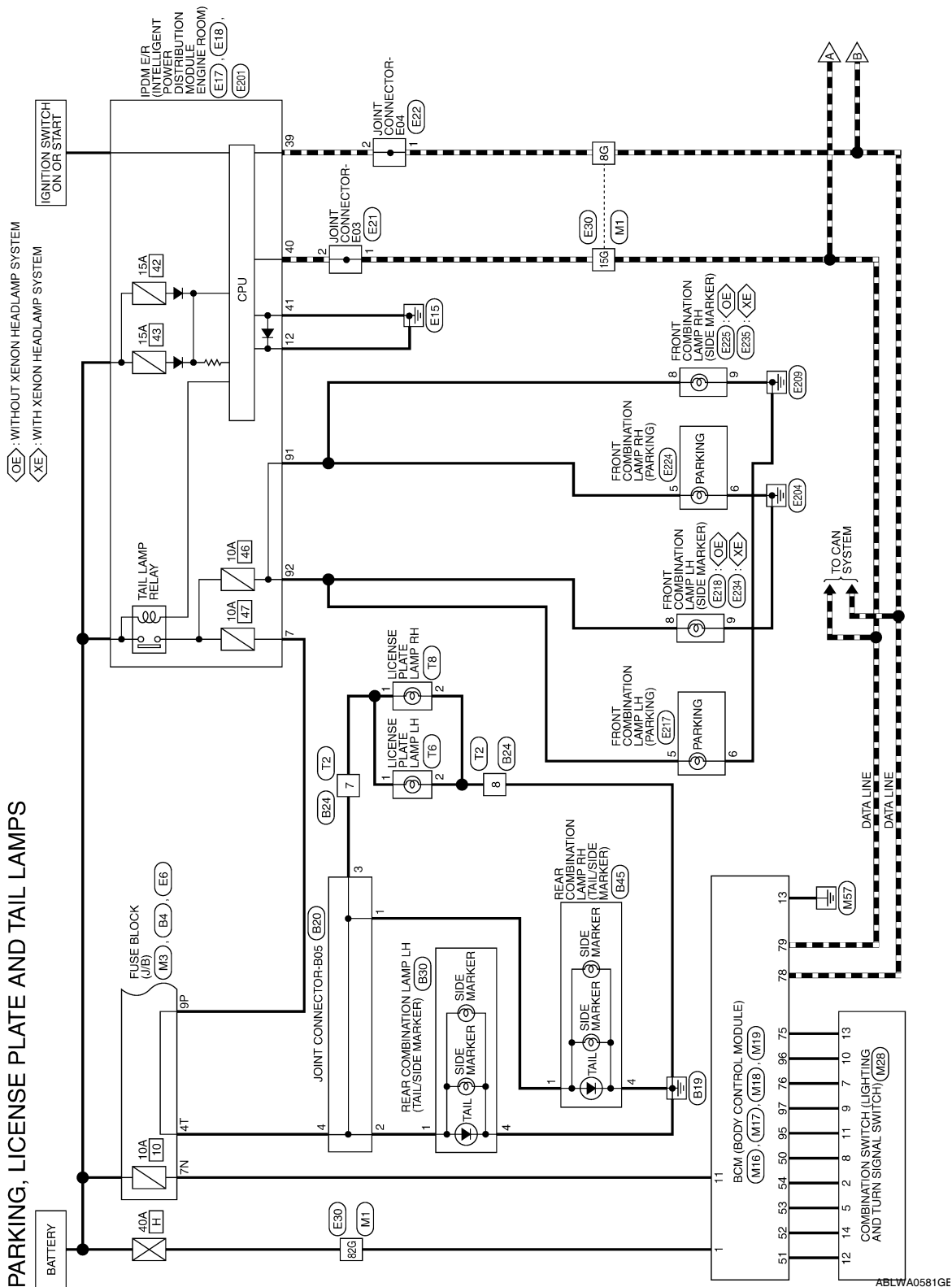

PARKING, LICENSE PLATE AND TAIL LAMPS SYSTEM

< COMPONENT DIAGNOSIS >

[HALOGEN TYPE]

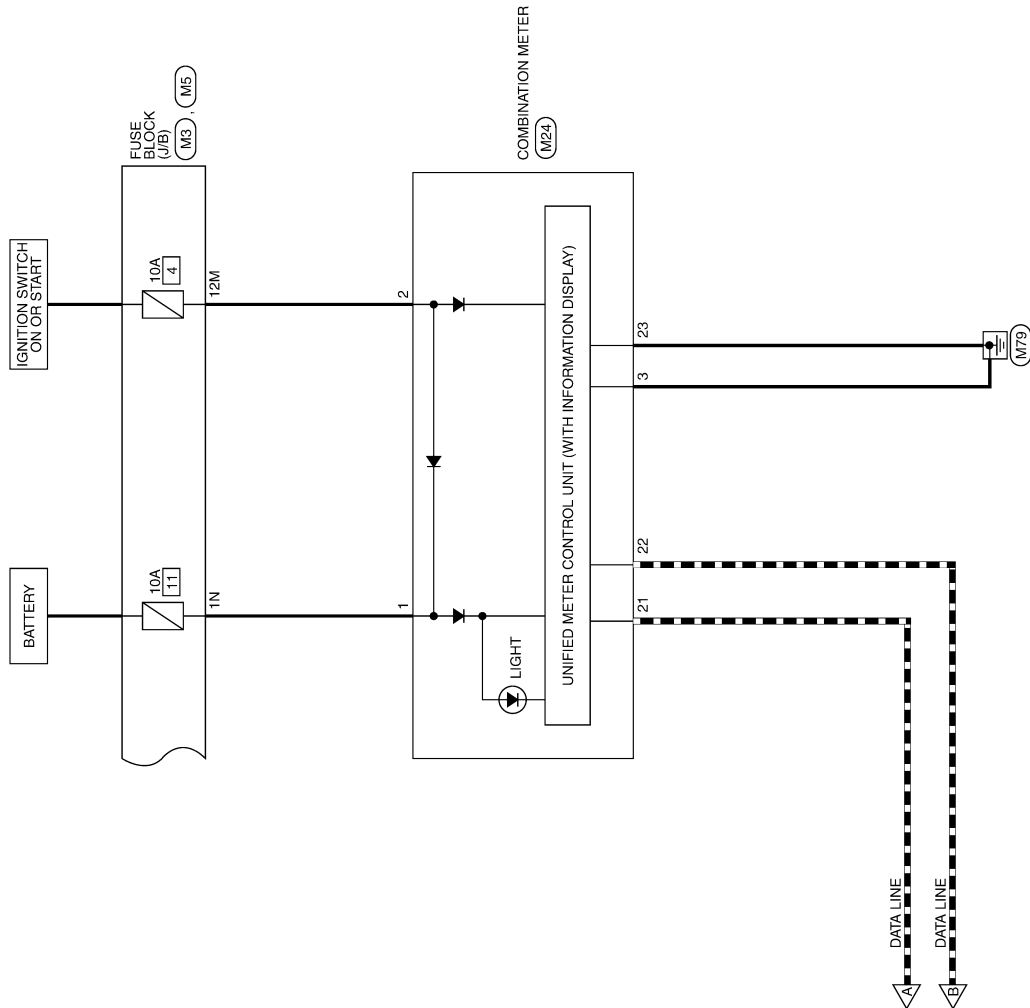

ABLWA0592GE

PARKING, LICENSE PLATE AND TAIL LAMPS SYSTEM

< COMPONENT DIAGNOSIS >

[HALOGEN TYPE]

PARKING, LICENCE PLATE AND TAIL LAMPS CONNECTORS

Connector No.	M1
Connector Name	WIRE TO WIRE
Connector Color	WHITE

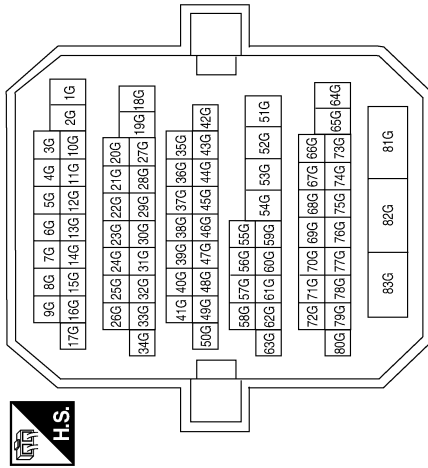

Terminal No.	Color of Wire	Signal Name
8G	P	-
15G	L	-
82G	W/B	-

Connector No.	M3
Connector Name	FUSE BLOCK (J/B)
Connector Color	WHITE

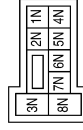

Terminal No.	Color of Wire	Signal Name
1N	W/L	-
7N	Y/R	-

Connector No.	M5
Connector Name	FUSE BLOCK (J/B)
Connector Color	WHITE

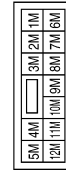

Connector No.	M16
Connector Name	BCM (BODY CONTROL MODULE)
Connector Color	BLACK



Connector No.	M17
Connector Name	BCM (BODY CONTROL MODULE)
Connector Color	WHITE

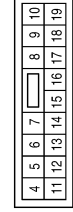

Terminal No.	12M	O	Signal Name	-
--------------	-----	---	-------------	---

Terminal No.	1	W/B	Signal Name	BATT (F/L)
--------------	---	-----	-------------	------------

Terminal No.	11	Y/R	Signal Name	BAT BCM FUSE
13	B	GND1		

ABLIA1755GB

A
B
C
D
E
F
G
H
I
J
K
L
M
N
O
P

EXL

PARKING, LICENSE PLATE AND TAIL LAMPS SYSTEM

< COMPONENT DIAGNOSIS >

[HALOGEN TYPE]

Connector No.	M24
Connector Name	COMBINATION METER
Connector Color	WHITE



1	2	3	4	5	6	7	8	9	10	11	12	13	14	15	16	17	18	19	20
21	22	23	24	25	26	27	28	29	30	31	32	33	34	35	36	37	38	39	40

Terminal No.	Color of Wire	Signal Name
1	W/L	BAT
2	O	IGN
3	B	GND (POWER)
21	L	CAN-H
22	H	CAN-L
23	B	GND (CIRCUIT)

Connector No.	M19
Connector Name	BCM (BODY CONTROL MODULE)
Connector Color	BLACK



79	78	77	76	75	74	73	72	71	70	69	68	67	66	65	64	63	62	61	60
99	98	97	96	95	94	93	92	91	90	89	88	87	86	85	84	83	82	81	80

Terminal No.	Color of Wire	Signal Name
75	R/Y	INPUT 5
76	R/G	INPUT 3
78	P	CAN-L
79	L	CAN-H
95	R/W	INPUT 1
96	P/B	INPUT 4
97	R/B	INPUT 2

Connector No.	M18
Connector Name	BCM (BODY CONTROL MODULE)
Connector Color	GREEN



39	38	37	36	35	34	33	32	31	30	29	28	27	26	25	24	23	22	21	20
59	58	57	56	55	54	53	52	51	50	49	48	47	46	45	44	43	42	41	40

Terminal No.	Color of Wire	Signal Name
50	LG/B	OUTPUT 5
51	L/W	OUTPUT 1
52	G/B	OUTPUT 2
53	LG/R	OUTPUT 3
54	G/Y	OUTPUT 4

Connector No.	E6
Connector Name	FUSE BLOCK (J/B)
Connector Color	WHITE



7P	6P	5P	4P	3P	2P	1P		
16P	15P	14P	13P	12P	11P	10P	9P	8P

Terminal No.	Color of Wire	Signal Name
9P	GR	-

Terminal No.	Color of Wire	Signal Name
9	R/B	INPUT 2
10	P/B	INPUT 4
11	R/W	INPUT 1
12	L/W	OUTPUT 1
13	R/Y	INPUT 5
14	G/B	OUTPUT 2

Connector No.	M28
Connector Name	COMBINATION SWITCH
Connector Color	WHITE



1	2	3	4	5	6		
7	8	9	10	11	12	13	14

Terminal No.	Color of Wire	Signal Name
2	G/Y	OUTPUT 4
5	LG/R	OUTPUT 3
7	R/G	INPUT 3
8	LG/B	OUTPUT 5

ABLIA1756GB

PARKING, LICENSE PLATE AND TAIL LAMPS SYSTEM

< COMPONENT DIAGNOSIS >

[HALOGEN TYPE]

Terminal No.	Color of Wire	Signal Name
7	GR	TAIL/ILLUMI
12	B	GND (POWER)

Connector No.	E18
Connector Name	IPDM E/R (INTELLIGENT POWER DISTRIBUTION MODULE ENGINE ROOM)
Connector Color	WHITE

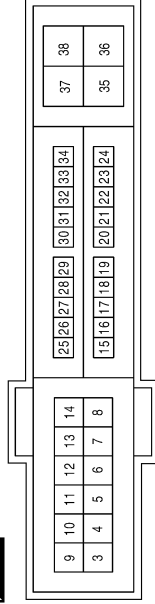

Connector No.	E17
Connector Name	IPDM E/R (INTELLIGENT POWER DISTRIBUTION MODULE ENGINE ROOM)
Connector Color	WHITE

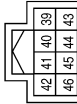

Terminal No.	Color of Wire	Signal Name
39	P	CAN-L
40	L	CAN-H
41	B	GND (SIGNAL)

Connector No.	E22
Connector Name	JOINT CONNECTOR-E04
Connector Color	WHITE



Terminal No.	Color of Wire	Signal Name
1	P	-
2	P	-

Connector No.	E21
Connector Name	JOINT CONNECTOR-E03
Connector Color	WHITE



Terminal No.	Color of Wire	Signal Name
1	L	-
2	L	-

ABLIA1757GB

A
B
C
D
E
F
G
H
I
J
K
EXL
M
N
O
P

PARKING, LICENSE PLATE AND TAIL LAMPS SYSTEM

< COMPONENT DIAGNOSIS >

[HALOGEN TYPE]

Connector No.	E201
Connector Name	IPDM E/R (INTELLIGENT POWER DISTRIBUTION MODULE ENGINE ROOM)
Connector Color	WHITE

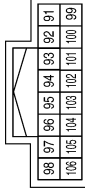

Terminal No.	Color of Wire	Signal Name
91	LG/R	CLEARANCE RH
92	LG/B	CLEARANCE LH

Terminal No.	Color of Wire	Signal Name
8G	P	-
15G	L	-
82G	LG	-

Connector No.	E30
Connector Name	WIRE TO WIRE
Connector Color	WHITE

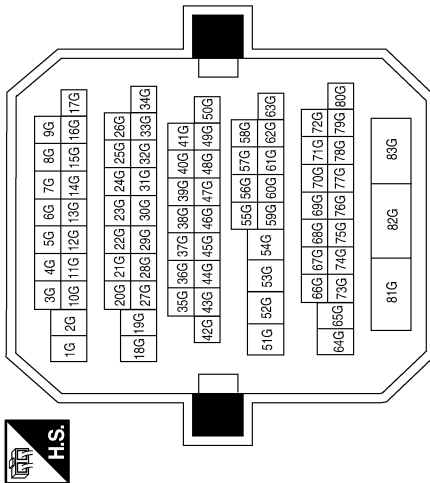

Connector No.	E224
Connector Name	FRONT COMBINATION LAMP RH
Connector Color	GRAY



Terminal No.	Color of Wire	Signal Name
5	LG/R	-
6	B	-

Connector No.	E218
Connector Name	FRONT COMBINATION LAMP LH (WITHOUT XENON HEADLAMP SYSTEM)
Connector Color	GRAY



Terminal No.	Color of Wire	Signal Name
8	LG/B	-
9	B	-

Connector No.	E217
Connector Name	FRONT COMBINATION LAMP LH
Connector Color	GRAY



Terminal No.	Color of Wire	Signal Name
5	LG/B	-
6	B	-

ABLIA1720GB

PARKING, LICENSE PLATE AND TAIL LAMPS SYSTEM

< COMPONENT DIAGNOSIS >

[HALOGEN TYPE]

Connector No.	E235
Connector Name	FRONT COMBINATION LAMP RH (WITH XENON HEADLAMP SYSTEM)
Connector Color	GRAY



Terminal No.	Color of Wire	Signal Name
8	LG/R	-
9	B	-

Connector No.	E234
Connector Name	FRONT COMBINATION LAMP LH (WITH XENON HEADLAMP SYSTEM)
Connector Color	GRAY



Terminal No.	Color of Wire	Signal Name
8	LG/B	-
9	B	-

Connector No.	E225
Connector Name	FRONT COMBINATION LAMP RH (WITHOUT XENON HEADLAMP SYSTEM)
Connector Color	GRAY



Terminal No.	Color of Wire	Signal Name
8	LG/R	-
9	B	-

Connector No.	B24
Connector Name	WIRE TO WIRE
Connector Color	WHITE

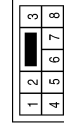

Terminal No.	Color of Wire	Signal Name
7	L	-
8	B	-

Connector No.	B20
Connector Name	JOINT CONNECTOR-B05
Connector Color	BLUE



Terminal No.	Color of Wire	Signal Name
1	L	-
2	L	-
3	L	-
4	L	-

Connector No.	B4
Connector Name	FUSE BLOCK (J/B)
Connector Color	BROWN



Terminal No.	Color of Wire	Signal Name
4T	L	-

ABLIA1721GB

A
B
C
D
E
F
G
H
I
J
K
L
M
N
O
P

EXL

PARKING, LICENSE PLATE AND TAIL LAMPS SYSTEM

< COMPONENT DIAGNOSIS >

[HALOGEN TYPE]

Connector No.	T2
Connector Name	WIRE TO WIRE
Connector Color	WHITE

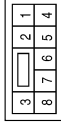

Terminal No.	Color of Wire	Signal Name
7	L	-
8	B	-

Connector No.	B45
Connector Name	REAR COMBINATION LAMP RH
Connector Color	WHITE

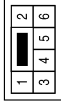

Terminal No.	Color of Wire	Signal Name
1	L	-
4	B	-

Connector No.	B30
Connector Name	REAR COMBINATION LAMP LH
Connector Color	WHITE

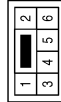

Terminal No.	Color of Wire	Signal Name
1	L	-
4	B	-

Connector No.	T8
Connector Name	LICENSE PLATE LAMP RH
Connector Color	BROWN



Terminal No.	Color of Wire	Signal Name
1	L	-
2	B	-

Connector No.	T6
Connector Name	LICENSE PLATE LAMP LH
Connector Color	BROWN



Terminal No.	Color of Wire	Signal Name
1	L	-
2	B	-

ABLIA1722GB

STOP LAMP

< COMPONENT DIAGNOSIS >

[HALOGEN TYPE]

STOP LAMP

Wiring Diagram

INFOID:000000005530283

- OS : WITHOUT REAR SPOILER
- RS : WITH REAR SUNSHADE
- RT : WITHOUT REAR SUNSHADE
- SP : WITH REAR SPOILER

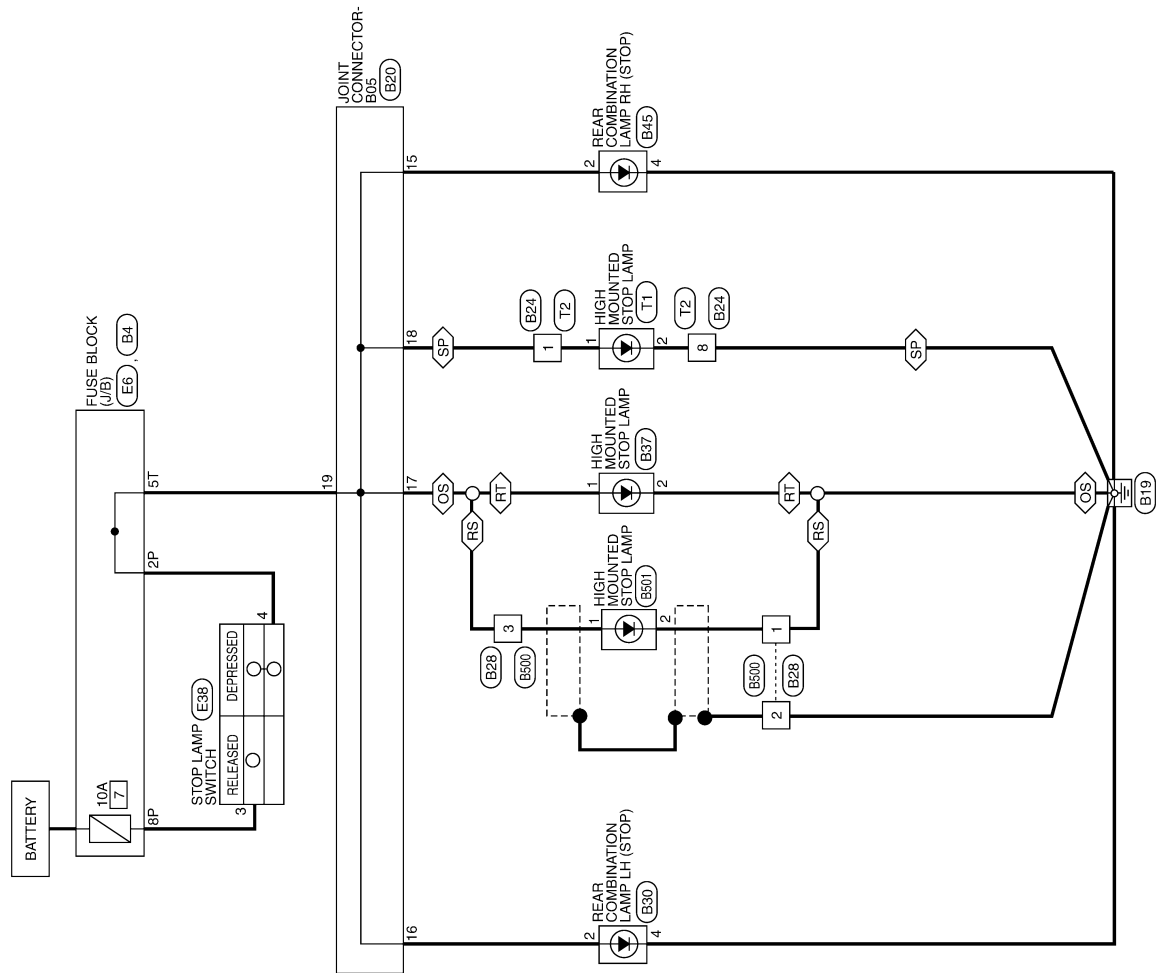

STOP LAMP

A
B
C
D
E
F
G
H
I
J
K
EXL
M
N
O
P

ABLWA0583GE

STOP LAMP

< COMPONENT DIAGNOSIS >

[HALOGEN TYPE]

STOP LAMP CONNECTORS

Connector No.	E6
Connector Name	FUSE BLOCK (J/B)
Connector Color	WHITE



Terminal No.	Color of Wire	Signal Name
2P	LG	-
8P	R	-

Connector No.	E38
Connector Name	STOP LAMP SWITCH
Connector Color	WHITE



Terminal No.	Color of Wire	Signal Name
3	R	-
4	LG	-

Connector No.	B4
Connector Name	FUSE BLOCK (J/B)
Connector Color	BROWN



Terminal No.	Color of Wire	Signal Name
5T	O	-

Connector No.	B20
Connector Name	JOINT CONNECTOR-B05
Connector Color	BLUE

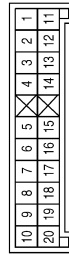

Terminal No.	Color of Wire	Signal Name
15	O	-
16	O	-
17	O	-
18	O	-
19	O	-

Connector No.	B24
Connector Name	WIRE TO WIRE
Connector Color	WHITE

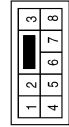

Terminal No.	Color of Wire	Signal Name
1	O	-
8	B	-

Connector No.	B28
Connector Name	WIRE TO WIRE
Connector Color	WHITE



Terminal No.	Color of Wire	Signal Name
1	B	-
2	B	-
3	O	-

STOP LAMP

< COMPONENT DIAGNOSIS >

[HALOGEN TYPE]

Connector No.	B45
Connector Name	REAR COMBINATION LAMP RH
Connector Color	WHITE

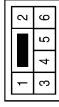

Terminal No.	Color of Wire	Signal Name
2	O	-
4	B	-

Connector No.	B37
Connector Name	HIGH MOUNTED STOP LAMP (WITHOUT REAR SPOILER AND REAR SUNSHADE)
Connector Color	WHITE



Terminal No.	Color of Wire	Signal Name
1	O	-
2	B	-

Connector No.	B30
Connector Name	REAR COMBINATION LAMP LH
Connector Color	WHITE

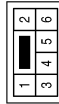

Terminal No.	Color of Wire	Signal Name
2	O	-
4	B	-

Connector No.	T1
Connector Name	HIGH MOUNTED STOP LAMP (WITH REAR SPOILER)
Connector Color	BROWN



Terminal No.	Color of Wire	Signal Name
1	O	-
2	B	-

Connector No.	B501
Connector Name	HIGH MOUNTED STOP LAMP (WITHOUT REAR SPOILER AND WITH REAR SUNSHADE)
Connector Color	GRAY



Terminal No.	Color of Wire	Signal Name
1	O	+
2	B	-

Connector No.	B500
Connector Name	WIRE TO WIRE
Connector Color	WHITE



Terminal No.	Color of Wire	Signal Name
1	B	-
2	B	-
3	O	-

ABLIA1754GB

A
B
C
D
E
F
G
H
I
J
K
EXL
M
N
O
P

STOP LAMP

< COMPONENT DIAGNOSIS >

[HALOGEN TYPE]

Connector No.	T2
Connector Name	WIRE TO WIRE
Connector Color	WHITE

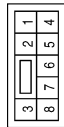

Terminal No.	Color of Wire	Signal Name
1	O	-
8	B	-

ABLIA0528GB

BACK-UP LAMP

< COMPONENT DIAGNOSIS >

[HALOGEN TYPE]

BACK-UP LAMP

Wiring Diagram

INFOID:000000005530284

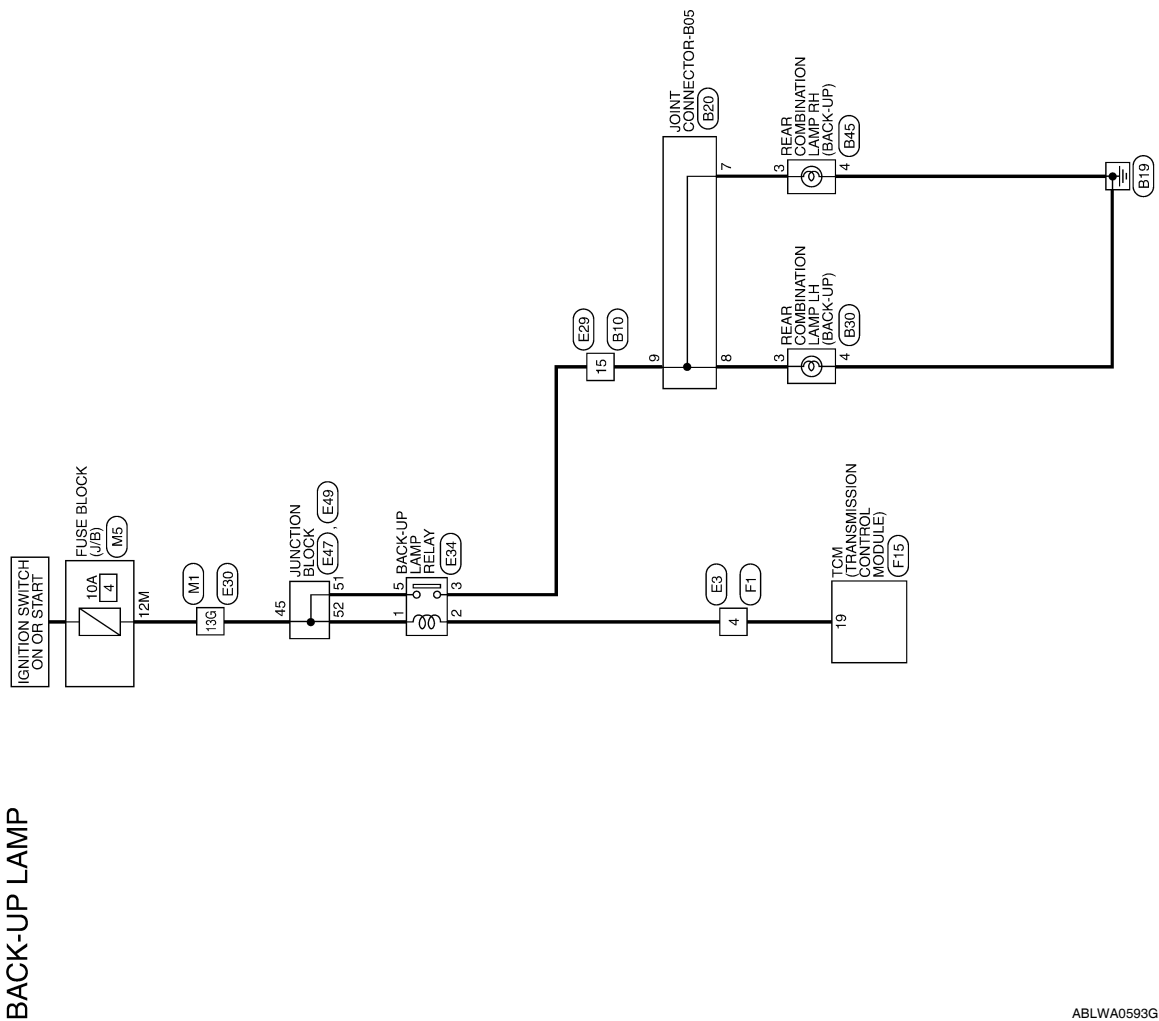

A
B
C
D
E
F
G
H
I
J
K
EXL
M
N
O
P

BACK-UP LAMP

BACK-UP LAMP

< COMPONENT DIAGNOSIS >

[HALOGEN TYPE]

BACK-UP LAMP CONNECTORS

Connector No.	M1
Connector Name	WIRE TO WIRE
Connector Color	WHITE

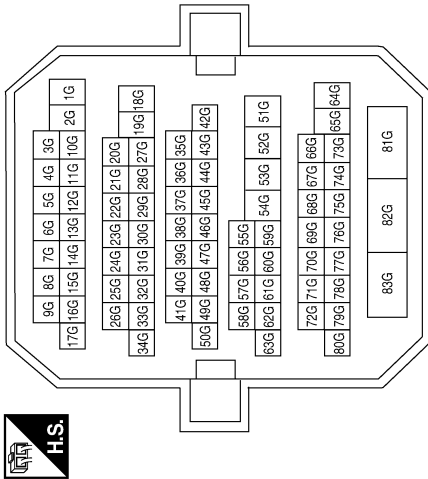

Terminal No.	Color of Wire	Signal Name
13G	O	-

Connector No.	M5
Connector Name	FUSE BLOCK (J/B)
Connector Color	WHITE

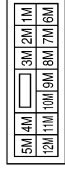

Terminal No.	Color of Wire	Signal Name
12M	O	-

Connector No.	E3
Connector Name	WIRE TO WIRE
Connector Color	WHITE

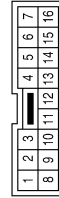

Terminal No.	Color of Wire	Signal Name
4	R	-

Connector No.	E29
Connector Name	WIRE TO WIRE
Connector Color	WHITE

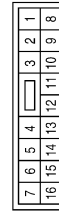

Terminal No.	Color of Wire	Signal Name
15	W	-

BACK-UP LAMP

< COMPONENT DIAGNOSIS >

[HALOGEN TYPE]

Connector No.	E34
Connector Name	BACK-UP LAMP RELAY
Connector Color	BLUE



Terminal No.	Color of Wire	Signal Name
1	O	-
2	R	-
3	W	-
5	LG	-

Terminal No.	Color of Wire	Signal Name
13G	BR	-

Connector No.	E30
Connector Name	WIRE TO WIRE
Connector Color	WHITE

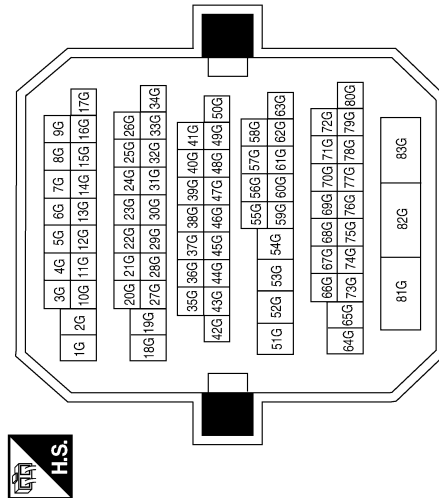

Connector No.	E49
Connector Name	JUNCTION BLOCK
Connector Color	BROWN

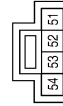

Terminal No.	Color of Wire	Signal Name
51	LG	-
52	O	-

Connector No.	E47
Connector Name	JUNCTION BLOCK
Connector Color	WHITE



Terminal No.	Color of Wire	Signal Name
45	BR	-

A
B
C
D
E
F
G
H
I
J
K
L
M
N
O
P

EXL

BACK-UP LAMP

< COMPONENT DIAGNOSIS >

[HALOGEN TYPE]

Connector No.	B10
Connector Name	WIRE TO WIRE
Connector Color	WHITE

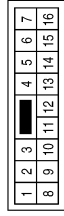

Terminal No.	15	Color of Wire	V	Signal Name	-
--------------	----	---------------	---	-------------	---

Connector No.	F15
Connector Name	TCM (TRANSMISSION CONTROL MODULE)
Connector Color	BLACK

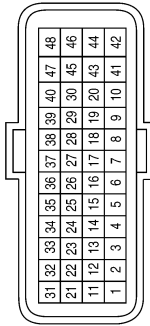

Terminal No.	19	Color of Wire	G/B	Signal Name	REV LAMP RLY
--------------	----	---------------	-----	-------------	--------------

Connector No.	F1
Connector Name	WIRE TO WIRE
Connector Color	WHITE

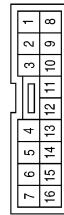

Terminal No.	4	Color of Wire	G/B	Signal Name	-
--------------	---	---------------	-----	-------------	---

Connector No.	B45
Connector Name	REAR COMBINATION LAMP RH
Connector Color	WHITE

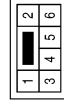

Terminal No.	3	Color of Wire	V	Signal Name	-
4	B	B	B	-	

Connector No.	B30
Connector Name	REAR COMBINATION LAMP LH
Connector Color	WHITE

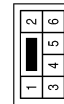

Terminal No.	3	Color of Wire	V	Signal Name	-
4	B	B	B	-	

Connector No.	B20
Connector Name	JOINT CONNECTOR-B05
Connector Color	BLUE

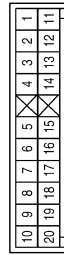

Terminal No.	7	Color of Wire	V	Signal Name	-
8	V	V	V	-	
9	V	V	V	-	

ABLIA1723GB

BCM (BODY CONTROL MODULE)

[HALOGEN TYPE]

< ECU DIAGNOSIS >

ECU DIAGNOSIS

BCM (BODY CONTROL MODULE)

Reference Value

INFOID:000000005530251

VALUES ON THE DIAGNOSIS TOOL

Monitor Item	Condition	Value/Status
FR WIPER HI	Other than front wiper switch HI	OFF
	Front wiper switch HI	ON
FR WIPER LOW	Other than front wiper switch LO	OFF
	Front wiper switch LO	ON
FR WASHER SW	Front washer switch OFF	OFF
	Front washer switch ON	ON
FR WIPER INT	Other than front wiper switch INT	OFF
	Front wiper switch INT	ON
FR WIPER STOP	Front wiper is not in STOP position	OFF
	Front wiper is in STOP position	ON
INT VOLUME	Wiper intermittent dial is in a dial position 1 - 7	Wiper intermittent dial position
TURN SIGNAL R	Other than turn signal switch RH	OFF
	Turn signal switch RH	ON
TURN SIGNAL L	Other than turn signal switch LH	OFF
	Turn signal switch LH	ON
TAIL LAMP SW	Other than lighting switch 1ST and 2ND	OFF
	Lighting switch 1ST or 2ND	ON
HI BEAM SW	Other than lighting switch HI	OFF
	Lighting switch HI	ON
HEAD LAMP SW 1	Other than lighting switch 2ND	OFF
	Lighting switch 2ND	ON
HEAD LAMP SW 2	Other than lighting switch 2ND	OFF
	Lighting switch 2ND	ON
PASSING SW	Other than lighting switch PASS	OFF
	Lighting switch PASS	ON
AUTO LIGHT SW	Other than lighting switch AUTO	OFF
	Lighting switch AUTO	ON
FR FOG SW	Front fog lamp switch OFF	OFF
	Front fog lamp switch ON	ON
DOOR SW-DR	Driver door closed	OFF
	Driver door opened	ON
DOOR SW-AS	Passenger door closed	OFF
	Passenger door opened	ON
DOOR SW-RR	Rear door RH closed	OFF
	Rear door RH opened	ON
DOOR SW-RL	Rear door LH closed	OFF
	Rear door LH opened	ON

BCM (BODY CONTROL MODULE)

< ECU DIAGNOSIS >

[HALOGEN TYPE]

Monitor Item	Condition	Value/Status
CDL LOCK SW	Other than power door lock switch LOCK	OFF
	Power door lock switch LOCK	ON
CDL UNLOCK SW	Other than power door lock switch UNLOCK	OFF
	Power door lock switch UNLOCK	ON
KEY CYL LK-SW	Other than driver door key cylinder LOCK position	OFF
	Driver door key cylinder LOCK position	ON
KEY CYL UN-SW	Other than driver door key cylinder UNLOCK position	OFF
	Driver door key cylinder UNLOCK position	ON
HAZARD SW	When hazard switch is not pressed	OFF
	When hazard switch is pressed	ON
REAR DEF SW	When rear window defogger switch is pressed	ON
TR CANCEL SW	Trunk lid opener cancel switch OFF	OFF
	Trunk lid opener cancel switch ON	ON
TR/BD OPEN SW	Trunk lid opener switch OFF	OFF
	While the trunk lid opener switch is turned ON	ON
TRNK/HAT MNTR	Trunk lid closed	OFF
	Trunk lid opened	ON
RKE-LOCK	When LOCK button of Intelligent Key is not pressed	OFF
	When LOCK button of Intelligent Key is pressed	ON
RKE-UNLOCK	When UNLOCK button of Intelligent Key is not pressed	OFF
	When UNLOCK button of Intelligent Key is pressed	ON
RKE-TR/BD	When TRUNK OPEN button of Intelligent Key is not pressed	OFF
	When TRUNK OPEN button of Intelligent Key is pressed	ON
RKE-PANIC	When PANIC button of Intelligent Key is not pressed	OFF
	When PANIC button of Intelligent Key is pressed	ON
RKE-P/W OPEN	When UNLOCK button of Intelligent Key is not pressed and held	OFF
	When UNLOCK button of Intelligent Key is pressed and held	ON
RKE-MODE CHG	When LOCK/UNLOCK button of Intelligent Key is not pressed and held simultaneously	OFF
	When LOCK/UNLOCK button of Intelligent Key is pressed and held simultaneously	ON
OPTICAL SENSOR	When outside of the vehicle is bright	Close to 5 V
	When outside of the vehicle is dark	Close to 0 V
REQ SW-DR	When front door request switch is not pressed (driver side)	OFF
	When front door request switch is pressed (driver side)	ON
REQ SW-AS	When front door request switch is not pressed (passenger side)	OFF
	When front door request switch is pressed (passenger side)	ON
REQ SW-RL	When rear door request switch is not pressed (driver side)	OFF
	When rear door request switch is pressed (driver side)	ON
REQ SW-RR	When rear door request switch is not pressed (passenger side)	OFF
	When rear door request switch is pressed (passenger side)	ON
REQ SW-BD/TR	When trunk request switch is not pressed	OFF
	When trunk request switch is pressed	ON
PUSH SW	When engine switch (push switch) is not pressed	OFF
	When engine switch (push switch) is pressed	ON

BCM (BODY CONTROL MODULE)

[HALOGEN TYPE]

< ECU DIAGNOSIS >

Monitor Item	Condition	Value/Status	
IGN RLY 2-F/B	Ignition switch OFF or ACC	OFF	A
	Ignition switch ON	ON	
ACC RLY-F/B	Ignition switch OFF	OFF	B
	Ignition switch ACC or ON	ON	
BRAKE SW 1	When the brake pedal is not depressed	ON	C
	When the brake pedal is depressed	OFF	
DETE/CANCL SW	When selector lever is in P position	OFF	D
	When selector lever is in any position other than P	ON	
SFT PN/N SW	When selector lever is in any position other than P or N	OFF	E
	When selector lever is in P or N position	ON	
S/L-LOCK*	Electronic steering column lock LOCK status	OFF	F
	Electronic steering column lock UNLOCK status	ON	
S/L-UNLOCK*	Electronic steering column lock UNLOCK status	OFF	G
	Electronic steering column lock LOCK status	ON	
S/L RELAY-F/B*	Ignition switch OFF or ACC	OFF	H
	Ignition switch ON	ON	
UNLK SEN-DR	Driver door UNLOCK status	OFF	I
	Driver door LOCK status	ON	
PUSH SW-IPDM	When engine switch (push switch) is not pressed	OFF	J
	When engine switch (push switch) is pressed	ON	
IGN RLY1 F/B	Ignition switch OFF or ACC	OFF	K
	Ignition switch ON	ON	
DETE SW -IPDM	When selector lever is in P position	OFF	EXL
	When selector lever is in any position other than P	ON	
SFT PN -IPDM	When selector lever is in any position other than P or N	OFF	M
	When selector lever is in P or N position	ON	
SFT P-MET	When selector lever is in any position other than P	OFF	N
	When selector lever is in P position	ON	
SFT N-MET	When selector lever is in any position other than N	OFF	O
	When selector lever is in N position	ON	
ENGINE STATE	Engine stopped	STOP	P
	While the engine stalls	STALL	
	At engine cranking	CRANK	
	Engine running	RUN	
S/L LOCK-IPDM*	Electronic steering column lock LOCK status	OFF	
	Electronic steering column lock UNLOCK status	ON	
S/L UNLK-IPDM*	Electronic steering column lock UNLOCK status	OFF	
	Electronic steering column lock LOCK status	ON	
S/L RELAY-REQ*	Ignition switch OFF or ACC	OFF	
	Ignition switch ON	ON	
VEH SPEED 1	While driving	Equivalent to speedometer reading	
VEH SPEED 2	While driving	Equivalent to speedometer reading	

BCM (BODY CONTROL MODULE)

< ECU DIAGNOSIS >

[HALOGEN TYPE]

Monitor Item	Condition	Value/Status
DOOR STAT-DR	Driver door LOCK status	LOCK
	Wait with selective UNLOCK operation (5 seconds)	READY
	Driver door UNLOCK status	UNLK
DOOR STAT-AS	Passenger door LOCK status	LOCK
	Wait with selective UNLOCK operation (5 seconds)	READY
	Passenger door UNLOCK status	UNLK
ID OK FLAG	Ignition switch ACC or ON	RESET
	Ignition switch OFF	SET
PRMT ENG STRT	When the engine start is prohibited	RESET
	When the engine start is permitted	SET
KEY SW -SLOT	When Intelligent Key is not inserted into key slot	OFF
	When Intelligent Key is inserted into key slot	ON
RKE OPE COUN1	During the operation of Intelligent Key	Operation frequency of Intelligent Key
CONFIRM ID ALL	The key ID that the key slot receives does not accord with any key ID registered to BCM.	YET
	The key ID that the key slot receives accords with any key ID registered to BCM.	DONE
CONFIRM ID4	The key ID that the key slot receives does not accord with the fourth key ID registered to BCM.	YET
	The key ID that the key slot receives accords with the fourth key ID registered to BCM.	DONE
CONFIRM ID3	The key ID that the key slot receives does not accord with the third key ID registered to BCM.	YET
	The key ID that the key slot receives accords with the third key ID registered to BCM.	DONE
CONFIRM ID2	The key ID that the key slot receives does not accord with the second key ID registered to BCM.	YET
	The key ID that the key slot receives accords with the second key ID registered to BCM.	DONE
CONFIRM ID1	The key ID that the key slot receives does not accord with the first key ID registered to BCM.	YET
	The key ID that the key slot receives accords with the first key ID registered to BCM.	DONE
TP 4	The ID of fourth key is not registered to BCM	YET
	The ID of fourth key is registered to BCM	DONE
TP 3	The ID of third key is not registered to BCM	YET
	The ID of third key is registered to BCM	DONE
TP 2	The ID of second key is not registered to BCM	YET
	The ID of second key is registered to BCM	DONE
TP 1	The ID of first key is not registered to BCM	YET
	The ID of first key is registered to BCM	DONE
AIR PRESS FL	Ignition switch ON (only when the signal from the transmitter is received)	Air pressure of front LH tire
AIR PRESS FR	Ignition switch ON (only when the signal from the transmitter is received)	Air pressure of front RH tire
AIR PRESS RR	Ignition switch ON (only when the signal from the transmitter is received)	Air pressure of rear RH tire
AIR PRESS RL	Ignition switch ON (only when the signal from the transmitter is received)	Air pressure of rear LH tire

BCM (BODY CONTROL MODULE)

< ECU DIAGNOSIS >

[HALOGEN TYPE]

Monitor Item	Condition	Value/Status
ID REGST FL1	When ID of front LH tire transmitter is registered	DONE
	When ID of front LH tire transmitter is not registered	YET
ID REGST FR1	When ID of front RH tire transmitter is registered	DONE
	When ID of front RH tire transmitter is not registered	YET
ID REGST RR1	When ID of rear RH tire transmitter is registered	DONE
	When ID of rear RH tire transmitter is not registered	YET
ID REGST RL1	When ID of rear LH tire transmitter is registered	DONE
	When ID of rear LH tire transmitter is not registered	YET
WARNING LAMP	Tire pressure indicator OFF	OFF
	Tire pressure indicator ON	ON
BUZZER	Tire pressure warning alarm is not sounding	OFF
	Tire pressure warning alarm is sounding	ON

* : With electronic steering column lock

A
B
C
D
E
F
G
H
I
J
K
L
M
N
O
P

EXL

BCM (BODY CONTROL MODULE)

[HALOGEN TYPE]

< ECU DIAGNOSIS >

Terminal Layout

INFOID:000000005530252

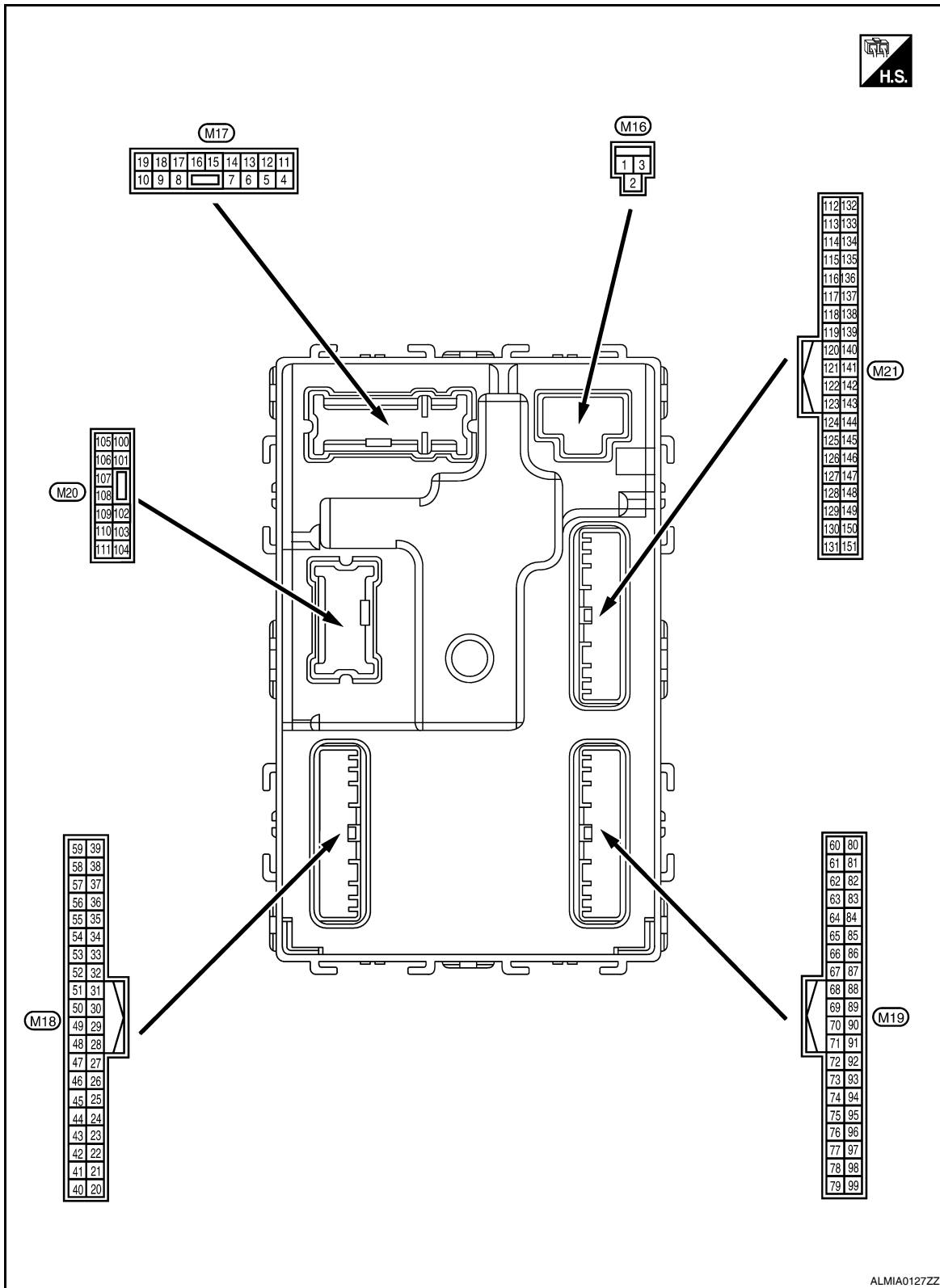

Physical Values

INFOID:000000005530253

BCM (BODY CONTROL MODULE)

< ECU DIAGNOSIS >

[HALOGEN TYPE]

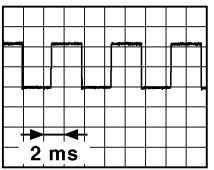
Terminal No. (Wire color)		Description		Condition		Value (Approx.)
		Signal name	Input/ Output			
(+)	(-)					
1 (W/B)	Ground	Battery power supply	Input	Ignition switch OFF		Battery voltage
2 (R/Y)	Ground	Battery power supply output	Output	Ignition switch OFF		Battery voltage
3 (L/W)	Ground	Ignition power supply output	Output	Ignition switch ON		Battery voltage
4 (P/W)	Ground	Interior room lamp power supply	Output	After passing the interior room lamp battery saver operation time		0V
				Any other time after passing the interior room lamp battery saver operation time		Battery voltage
5 (G)	Ground	Front door RH UNLOCK	Output	Front door RH	UNLOCK (actuator is activated)	Battery voltage
					Other than UNLOCK (actuator is not activated)	0V
7 (R/W)	Ground	Step lamp	Output	Step lamp	ON	0V
					OFF	Battery voltage
8 (V)	Ground	All doors LOCK	Output	All doors	LOCK (actuator is activated)	Battery voltage
					Other than LOCK (actuator is not activated)	0V
9 (L)	Ground	Front door LH UNLOCK	Output	Front door LH	UNLOCK (actuator is activated)	Battery voltage
					Other than UNLOCK (actuator is not activated)	0V
10 (G)	Ground	Rear door RH and rear door LH UNLOCK	Output	Rear door RH and rear door LH	UNLOCK (actuator is activated)	Battery voltage
					Other than UNLOCK (actuator is not activated)	0V
11 (Y/R)	Ground	Battery power supply	Input	Ignition switch OFF		Battery voltage
13 (B)	Ground	Ground	—	Ignition switch ON		0V
14 (GR/W)	Ground	Engine switch (push switch) illumination ground	Input	Tail lamp	OFF	0V
					ON	<p>NOTE: When the illumination brightening/dimming level is in the neutral position</p>  <p style="text-align: right; font-size: small;">JSNIA0010GB</p>
15 (Y/L)	Ground	ACC indicator lamp	Output	Ignition switch	OFF	Battery voltage
					ACC or ON	0V

A
B
C
D
E
F
G
H
I
J
K
EXL
M
N
O
P

BCM (BODY CONTROL MODULE)

[HALOGEN TYPE]

< ECU DIAGNOSIS >

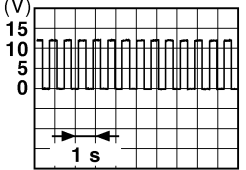
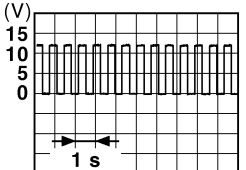
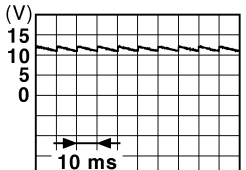
Terminal No. (Wire color)		Description		Condition		Value (Approx.)
(+)	(-)	Signal name	Input/ Output			
17 (G/B)	Ground	Turn signal (RH)	Output	Ignition switch ON	Turn signal switch OFF	0V
					Turn signal switch RH	 <p style="text-align: center;">6.5 V</p>
18 (G/Y)	Ground	Turn signal (LH)	Output	Ignition switch ON	Turn signal switch OFF	0V
					Turn signal switch LH	 <p style="text-align: center;">6.5 V</p>
19 (Y)	Ground	Room lamp timer control	Output	Interior room lamp	OFF	Battery voltage
					ON	0V
21 (P/B)	Ground	Optical sensor signal	Input	Ignition switch ON	When outside of the vehi- cle is bright	Close to 5V
					When outside of the vehi- cle is dark	Close to 0V
24 (R/W)	Ground	Stop lamp switch 1	Input	—	Battery voltage	
26 (O/L)	Ground	Stop lamp switch 2	Input	Stop lamp switch	OFF (brake pedal is re- leased)	0V
					ON (brake pedal is de- pressed)	Battery voltage
27 (O)	Ground	Front door lock as- sembly LH (unlock sensor)	Input	Front door LH	LOCK status	 <p style="text-align: center;">11.8V</p>
					UNLOCK status	0V
29 (Y)	Ground	Key slot switch	Input	When Intelligent Key is inserted into key slot	Battery voltage	
				When Intelligent Key is not inserted into key slot	0V	
30 (V/Y)	Ground	ACC feedback signal	Input	Ignition switch	OFF	0
				ACC or ON	Battery voltage	
31 (G)	Ground	Rear window defog- ger feedback signal	Input	Rear window de- fogger switch	OFF	0V
					ON	Battery voltage

BCM (BODY CONTROL MODULE)

< ECU DIAGNOSIS >

[HALOGEN TYPE]

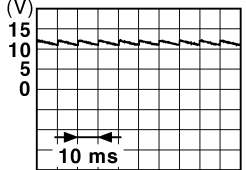
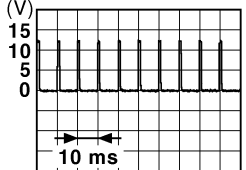
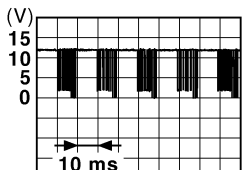

Terminal No. (Wire color)		Description		Condition		Value (Approx.)
(+)	(-)	Signal name	Input/ Output			
32 (R/B)	Ground	Front door RH switch	Input	Front door RH switch	OFF (when front door RH closes)	 11.8 V
					ON (when front door RH opens)	0V
37 (O)	Ground	Trunk lid opener cancel switch	Input	Trunk lid opener cancel switch	CANCEL	 1.1V
					ON	0V
38 (GR/W)	Ground	Rear window defogger ON signal	Input	Rear window defogger switch	OFF	5V
					ON	0V
40 (Y/G)	Ground	Power window serial link	Input/ Output	Ignition switch ON	 10.2V	
				Ignition switch OFF or ACC	0V	
41 (W)	Ground	Engine switch (push switch) illumination	Output	Engine switch (push switch) illumination	ON	5.5V
					OFF	0V
42 (R)	Ground	LOCK indicator lamp	Output	LOCK indicator lamp	ON	0V
					OFF	Battery voltage
45 (P)	Ground	Receiver & sensor ground	Input	Ignition switch ON	0V	N
46 (V/W)	Ground	Receiver & sensor power supply output	Output	Ignition switch	OFF	0V
					ACC or ON	5.0V

A
B
C
D
E
F
G
H
I
J
K
EXL
M
N
O
P

BCM (BODY CONTROL MODULE)

[HALOGEN TYPE]

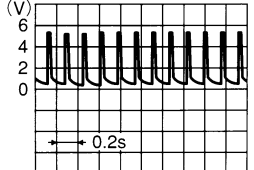
< ECU DIAGNOSIS >

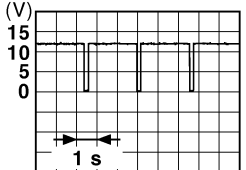
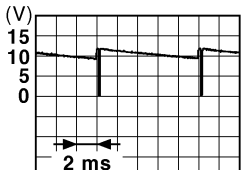
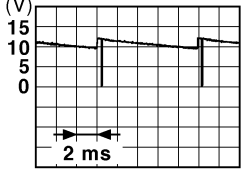
Terminal No. (Wire color)		Description		Condition	Value (Approx.)
(+)	(-)	Signal name	Input/ Output		
47 ¹ (G/O)	Ground	Tire pressure receiver signal	Input/ Output	Ignition switch ON	Standby state  OCC3881D
				When receiving the signal from the transmitter  OCC3880D	
48 (R/G)	Ground	Selector lever transmission range switch signal	Input	Selector lever	P or N position 12.0V
				Except P and N positions 0V	
49 (L/O)	Ground	Security indicator signal	Output	Security indicator	ON 0V
				Blinking  JPMIA0014GB 11.3V	
50 (LG/B)	Ground	Combination switch OUTPUT 5	Output	Combination switch (Wiper intermittent dial 4)	All switch OFF 0V
				Lighting switch 1ST	Turn signal switch RH  JPMIA0031GB 10.7V
				Lighting switch high-beam	
				Lighting switch 2ND	
51 (L/W)	Ground	Combination switch OUTPUT 1	Output	Combination switch	All switch OFF (Wiper intermittent dial 4) 0V
				Any of the conditions below with all switch OFF • Wiper intermittent dial 1 • Wiper intermittent dial 2 • Wiper intermittent dial 3 • Wiper intermittent dial 6 • Wiper intermittent dial 7  JPMIA0032GB 10.7V	

BCM (BODY CONTROL MODULE)

< ECU DIAGNOSIS >

[HALOGEN TYPE]

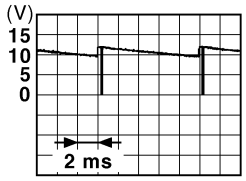
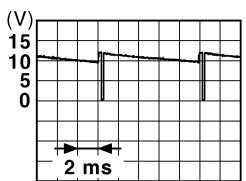
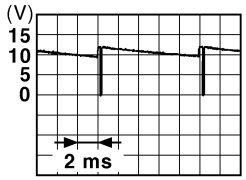
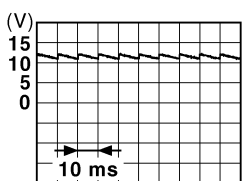
Terminal No. (Wire color)		Description		Condition	Value (Approx.)			
		Signal name	Input/ Output					
(+)	(-)							
52 (G/B)	Ground	Combination switch OUTPUT 2	Output	Combination switch	All switch OFF (Wiper intermittent dial 4)	0V		
					Front washer switch ON (Wiper intermittent dial 4)	 <p style="text-align: right; font-size: small;">JPMIA0033GB</p>		
					Any of the conditions below with all switch OFF <ul style="list-style-type: none"> • Wiper intermittent dial 1 • Wiper intermittent dial 5 • Wiper intermittent dial 6 		10.7V	
53 (LG/ R)	Ground	Combination switch OUTPUT 3	Output	Combination switch (Wiper intermit- tent dial 4)	All switch OFF	0V		
					Front wiper switch INT	 <p style="text-align: right; font-size: small;">JPMIA0034GB</p>		
					Front wiper switch LO			
					Lighting switch AUTO		10.7V	
54 (G/Y)	Ground	Combination switch OUTPUT 4	Output	Combination switch (Wiper intermit- tent dial 4)	All switch OFF	0V		
					Front fog lamp switch ON	 <p style="text-align: right; font-size: small;">JPMIA0035GB</p>		
					Lighting switch 2ND			
					Lighting switch flash-to-pass		10.7V	
		Turn signal switch LH						
57 ¹ (W)	Ground	Tire pressure warn- ing check switch	Input	—	5V			
58 (SB)	Ground	Front door LH switch	Input	Front door LH switch	OFF (front door LH CLOSE)	 <p style="text-align: right; font-size: small;">JPMIA0011GB</p>		
					ON (front door LH OPEN)	0V		
59 (G/R)	Ground	Rear window defog- ger relay	Output	Rear window de- fogger	Active	Battery voltage		
					Not activated	0V		

A
B
C
D
E
F
G
H
I
J
K
EXL
M
N
O
P

BCM (BODY CONTROL MODULE)

< ECU DIAGNOSIS >

[HALOGEN TYPE]

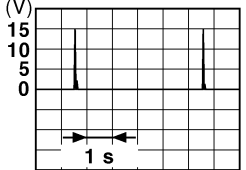
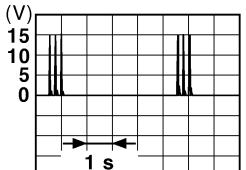
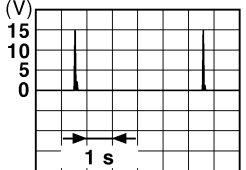
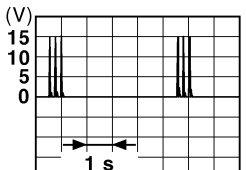
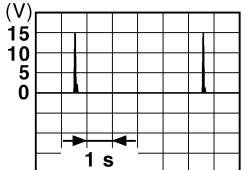
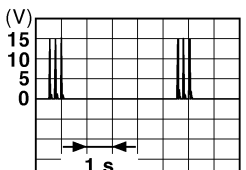
Terminal No. (Wire color)		Description		Condition	Value (Approx.)
(+)	(-)	Signal name	Input/ Output		
60 (B/R)	Ground	Front console antenna 2 (-)	Output	Ignition switch OFF	 <p style="text-align: right; font-size: small;">JMKIA0062GB</p>
				Ignition switch OFF	 <p style="text-align: right; font-size: small;">JMKIA0063GB</p>
61 (W/R)	Ground	Center console antenna 2 (+)	Output	Ignition switch OFF	 <p style="text-align: right; font-size: small;">JMKIA0062GB</p>
				Ignition switch OFF	 <p style="text-align: right; font-size: small;">JMKIA0063GB</p>
62 (V)	Ground	Front outside handle RH antenna (-)	Output	When the front door RH request switch is operated with ignition switch OFF	 <p style="text-align: right; font-size: small;">JMKIA0062GB</p>
				When the front door RH request switch is operated with ignition switch OFF	 <p style="text-align: right; font-size: small;">JMKIA0063GB</p>

BCM (BODY CONTROL MODULE)

< ECU DIAGNOSIS >

[HALOGEN TYPE]

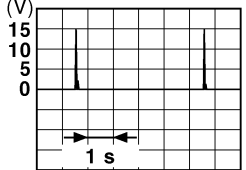
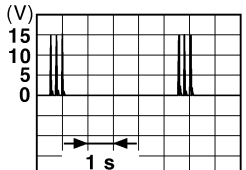
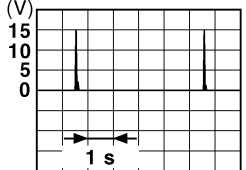
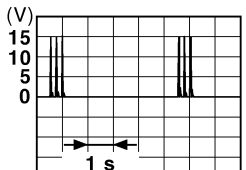
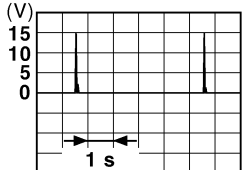
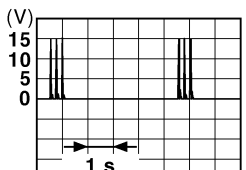
Terminal No. (Wire color)		Description		Condition	Value (Approx.)
(+)	(-)	Signal name	Input/ Output		
63 (P)	Ground	Front outside handle RH antenna (+)	Output	When the front door RH request switch is operat- ed with ignition switch OFF	 <p style="text-align: right; font-size: small;">JMKIA0062GB</p>
				When Intelligent Key is not in the antenna detection area	 <p style="text-align: right; font-size: small;">JMKIA0063GB</p>
64 (V)	Ground	Front outside handle LH antenna (-)	Output	When the front door LH request switch is operat- ed with ignition switch OFF	 <p style="text-align: right; font-size: small;">JMKIA0062GB</p>
				When Intelligent Key is not in the antenna detection area	 <p style="text-align: right; font-size: small;">JMKIA0063GB</p>
65 (P)	Ground	Front outside handle LH antenna (+)	Output	When the front door LH request switch is operat- ed with ignition switch OFF	 <p style="text-align: right; font-size: small;">JMKIA0062GB</p>
				When Intelligent Key is not in the antenna detection area	 <p style="text-align: right; font-size: small;">JMKIA0063GB</p>

A
B
C
D
E
F
G
H
I
J
K
EXL
M
N
O
P

BCM (BODY CONTROL MODULE)

< ECU DIAGNOSIS >

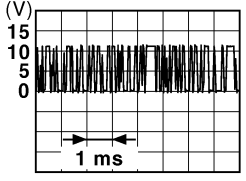
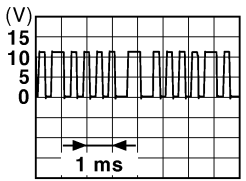
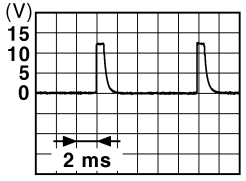
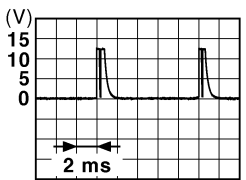
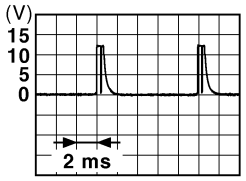

[HALOGEN TYPE]

Terminal No. (Wire color)		Description		Condition		Value (Approx.)
(+)	(-)	Signal name	Input/ Output			
68 (G/O)	Ground	NATS antenna amp (built in key slot)	Input/ Output	During waiting	Ignition switch is pressed while inserting the Intelli- gent Key into the key slot.	Just after pressing ignition switch. Pointer of tester should move.
69 (O)	Ground	NATS antenna amp (built in key slot)	Input/ Output	During waiting	Ignition switch is pressed while inserting the Intelli- gent Key into the key slot.	Just after pressing ignition switch. Pointer of tester should move.
70 (R/B)	Ground	Ignition relay-2 con- trol	Output	Ignition switch	OFF or ACC ON	0V Battery voltage
71 (L/O)	Ground	Remote keyless entry receiver signal	Input/ Output	During waiting		 <p style="text-align: right; font-size: small;">JMKIA0064GB</p>
				When operating either button on Intelligent Key		 <p style="text-align: right; font-size: small;">JMKIA0065GB</p>
75 (R/Y)	Ground	Combination switch INPUT 5	Input	Combination switch	All switch OFF (Wiper intermittent dial 4)	 <p style="text-align: right; font-size: small;">JPMIA0041GB</p> <p style="text-align: center;">1.4V</p>
					Front fog lamp switch ON (Wiper intermittent dial 4)	 <p style="text-align: right; font-size: small;">JPMIA0037GB</p> <p style="text-align: center;">1.3V</p>
					Any of the conditions below with all switch OFF • Wiper intermittent dial 1 • Wiper intermittent dial 2 • Wiper intermittent dial 6 • Wiper intermittent dial 7	 <p style="text-align: right; font-size: small;">JPMIA0040GB</p> <p style="text-align: center;">1.3V</p>

BCM (BODY CONTROL MODULE)

< ECU DIAGNOSIS >

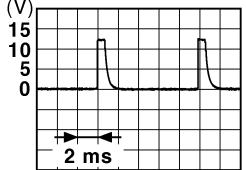
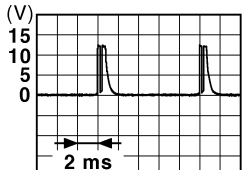
[HALOGEN TYPE]

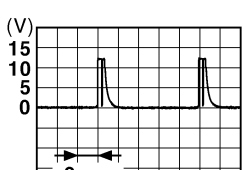
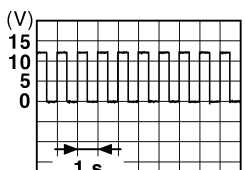
Terminal No. (Wire color)		Description		Condition	Value (Approx.)	
(+)	(-)	Signal name	Input/ Output			
76 (R/G)	Ground	Combination switch INPUT 3	Input	Combination switch	All switch OFF (Wiper intermittent dial 4)	 <small>JPMIA0041GB</small> 1.4V
					Lighting switch high-beam (Wiper intermittent dial 4)	 <small>JPMIA0036GB</small> 1.3V
					Lighting switch 2ND (Wiper intermittent dial 4)	 <small>JPMIA0037GB</small> 1.3V
					Any of the conditions below with all switch OFF • Wiper intermittent dial 1 • Wiper intermittent dial 2 • Wiper intermittent dial 3	 <small>JPMIA0040GB</small> 1.3V
77 ² (BR)	Ground	Engine switch (push switch)	Input	Engine switch (push switch)	Pressed Not pressed	0V Battery voltage
78 (P)	Ground	CAN-L	Input/ Output	—	—	
79 (L)	Ground	CAN-H	Input/ Output	—	—	
80 (R/L)	Ground	Key slot illumination	Output	Key slot illumina- tion	OFF	0V
					Blinking	 <small>JPMIA0015GB</small> 6.5V
					ON	Battery voltage

A
B
C
D
E
F
G
H
I
J
K

EXL

M
N
O
P

BCM (BODY CONTROL MODULE)

[HALOGEN TYPE]



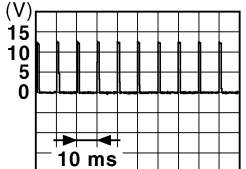
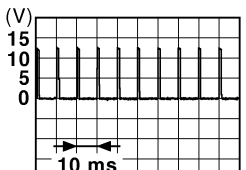

< ECU DIAGNOSIS >

Terminal No. (Wire color)		Description		Condition		Value (Approx.)
		Signal name	Input/ Output			
(+)	(-)					
81 (LG)	Ground	ON indicator lamp	Output	Ignition switch	OFF or ACC	0V
					ON	Battery voltage
83 (L)	Ground	ACC relay control	Output	Ignition switch	OFF	0V
					ACC or ON	Battery voltage
84 (Y/R)	Ground	CVT shift selector	Output	—		Battery voltage
85 ³ (L/O)	Ground	Electronic steering column lock condition No. 1	Input	Electronic steering column lock	Lock status	0V
					Unlock status	Battery voltage
86 ³ (G/R)	Ground	Electronic steering column lock condition No. 2	Input	Electronic steering column lock	Lock status	Battery voltage
					Unlock status	0V
87 (G/B)	Ground	Selector lever P position switch	Input	Selector lever	P position	0V
					Any position other than P	Battery voltage
88 (R)	Ground	Front door RH request switch	Input	Front door RH request switch	ON (pressed)	0V
					OFF (not pressed)	
89 (R)	Ground	Front door LH request switch	Input	Front door LH request switch	ON (pressed)	0V
					OFF (not pressed)	
90 (Y)	Ground	Blower fan motor relay control	Output	Ignition switch	OFF or ACC	0V
					ON	Battery voltage
91 (L/R)	Ground	Remote keyless entry receiver power supply	Output	Ignition switch OFF		Battery voltage
94 ³ (G/Y)	Ground	Steering wheel lock unit power supply	Output	Ignition switch	OFF or ACC	Battery voltage
					ON	0V

BCM (BODY CONTROL MODULE)

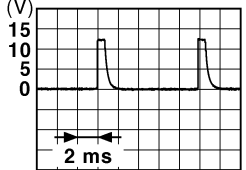
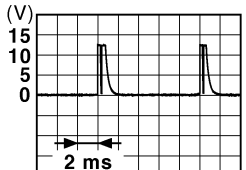
< ECU DIAGNOSIS >

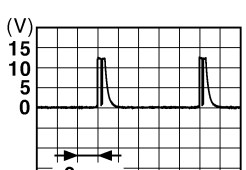
[HALOGEN TYPE]

Terminal No. (Wire color)		Description		Condition	Value (Approx.)
(+)	(-)	Signal name	Input/ Output		
95 (R/W)	Ground	Combination switch INPUT 1	Input	All switch OFF	 <small>JPMIA0041GB</small> 1.4V
				Turn signal switch LH	 <small>JPMIA0037GB</small> 1.3V
				Turn signal switch RH	 <small>JPMIA0036GB</small> 1.3V
				Front wiper switch LO	 <small>JPMIA0038GB</small> 1.3V
				Front washer switch ON	 <small>JPMIA0039GB</small> 1.3V

A
B
C
D
E
F
G
H
I
J
K
EXL
M
N
O
P

BCM (BODY CONTROL MODULE)

< ECU DIAGNOSIS >



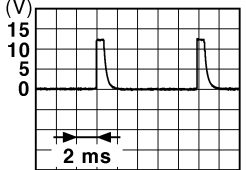
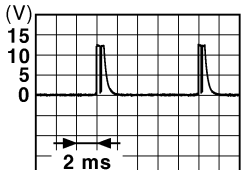
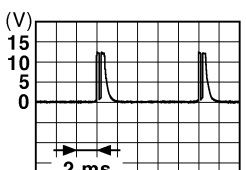
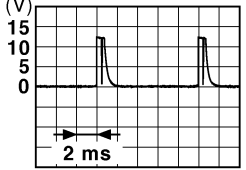

[HALOGEN TYPE]

Terminal No. (Wire color)		Description		Condition	Value (Approx.)
(+)	(-)	Signal name	Input/ Output		
96 (P/B)	Ground	Combination switch INPUT 4	Input	Combination switch	All switch OFF (Wiper intermittent dial 4)  <p style="text-align: right; font-size: small;">JPMIA0041GB</p> <p style="text-align: center;">1.4V</p>
					Lighting switch AUTO (Wiper intermittent dial 4)  <p style="text-align: right; font-size: small;">JPMIA0038GB</p> <p style="text-align: center;">1.3V</p>
					Lighting switch 1ST (Wiper intermittent dial 4)  <p style="text-align: right; font-size: small;">JPMIA0036GB</p> <p style="text-align: center;">1.3V</p>
					Any of the conditions below with all switch OFF <ul style="list-style-type: none"> • Wiper intermittent dial 1 • Wiper intermittent dial 5 • Wiper intermittent dial 6  <p style="text-align: right; font-size: small;">JPMIA0039GB</p> <p style="text-align: center;">1.3V</p>

BCM (BODY CONTROL MODULE)

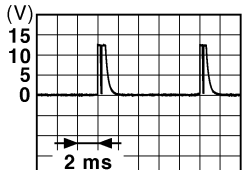
< ECU DIAGNOSIS >

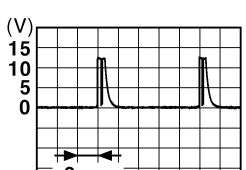
[HALOGEN TYPE]

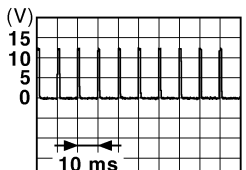
Terminal No. (Wire color)		Description		Condition	Value (Approx.)	
(+)	(-)	Signal name	Input/ Output			
97 (R/B)	Ground	Combination switch INPUT 2	Input			Combination switch (Wiper intermittent dial 4)
				Lighting switch flash-to-pass	 1.3V	
				Lighting switch 2ND	 1.3V	
				Front wiper switch INT	 1.3V	
				Front wiper switch HI	 1.3V	
				Pressed	0 V	
98 (G/O)	Ground	Hazard switch	Input	Hazard switch	Not pressed	 1.1V

A
B
C
D
E
F
G
H
I
J
K
L
M
N
O
P

EXL

BCM (BODY CONTROL MODULE)

[HALOGEN TYPE]

< ECU DIAGNOSIS >

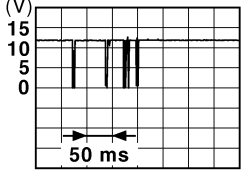
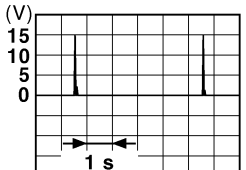
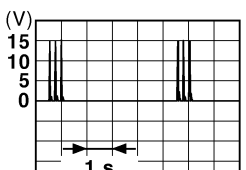
Terminal No. (Wire color)		Description		Condition	Value (Approx.)	
(+)	(-)	Signal name	Input/ Output			
99 ³ (L/Y)	Ground	Electronic steering column lock unit com- munication	Input/ Output	Electronic steer- ing column lock	LOCK status	Battery voltage
					LOCK or UNLOCK	 <p style="text-align: right; font-size: small;">JMKIA0066GB</p>
					For 15 seconds after UN- LOCK	Battery voltage
					15 seconds or later after UNLOCK	0V
103 (V)	Ground	Trunk lid opening.	Output	Trunk lid	Open (trunk lid opener ac- tuator is activated)	Battery voltage
					Close (trunk lid opener ac- tuator is not activated)	0V
110 (V/W)	Ground	Trunk room lamp	Output	Trunk room lamp	ON	0V
					OFF	Battery voltage
114 (B)	Ground	Trunk room antenna 1 (-)	Output	Ignition switch OFF	When Intelligent Key is in the passenger compart- ment	 <p style="text-align: right; font-size: small;">JMKIA0062GB</p>
					When Intelligent Key is not in the passenger compart- ment	 <p style="text-align: right; font-size: small;">JMKIA0063GB</p>

BCM (BODY CONTROL MODULE)

< ECU DIAGNOSIS >

[HALOGEN TYPE]

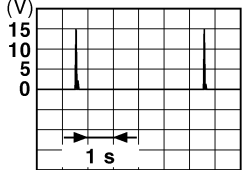
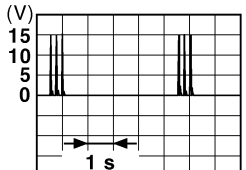
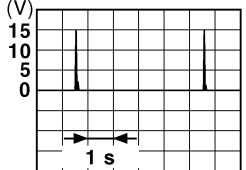
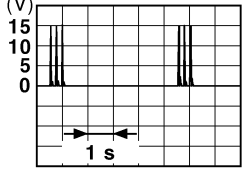
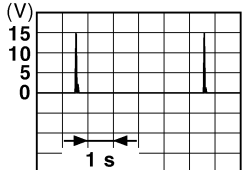
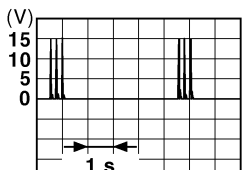
Terminal No. (Wire color)		Description		Condition	Value (Approx.)
(+)	(-)	Signal name	Input/ Output		
115 (W)	Ground	Trunk room antenna 1 (+)	Output	Ignition switch OFF	 <p style="text-align: right; font-size: small;">JMKIA0062GB</p>
				When Intelligent Key is not in the passenger compart- ment	 <p style="text-align: right; font-size: small;">JMKIA0063GB</p>
118 (L/O)	Ground	Rear bumper anten- na (-)	Output	When the trunk lid request switch is operated with ignition switch OFF	 <p style="text-align: right; font-size: small;">JMKIA0062GB</p>
				When Intelligent Key is not in the antenna detection area	 <p style="text-align: right; font-size: small;">JMKIA0063GB</p>
119 (BR/ W)	Ground	Rear bumper anten- na (+)	Output	When the trunk lid request switch is operated with ignition switch OFF	 <p style="text-align: right; font-size: small;">JMKIA0062GB</p>
				When Intelligent Key is not in the antenna detection area	 <p style="text-align: right; font-size: small;">JMKIA0063GB</p>

A
B
C
D
E
F
G
H
I
J
K
EXL
M
N
O
P

BCM (BODY CONTROL MODULE)

< ECU DIAGNOSIS >

[HALOGEN TYPE]

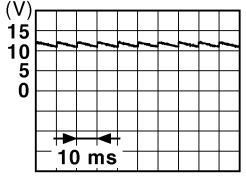
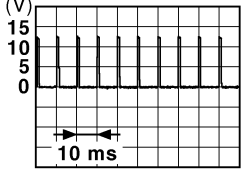
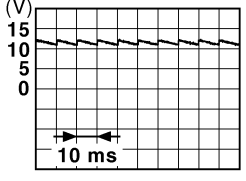
Terminal No. (Wire color)		Description		Condition		Value (Approx.)
(+)	(-)	Signal name	Input/ Output			
127 (BR/ W)	Ground	Ignition relay (IPDM E/R) control	Output	Ignition switch	OFF or ACC	Battery voltage
					ON	0V
130 (W)	Ground	Trunk room lamp switch	Input	Trunk room lamp switch	OFF (trunk is closed)	 <p style="text-align: right; font-size: small;">JPMIA0011GB</p> <p style="text-align: center;">11.8V</p>
					ON (trunk is open)	0V
132 (R)	Ground	Starter motor relay control	Output	Ignition switch ON	When selector lever is in P or N position and the brake is depressed	Battery voltage
					When selector lever is in P or N position and the brake is not depressed	0V
140 ⁴ (L/R)	Ground	Engine switch (push switch)	Input	Engine switch (push switch)	Pressed	0V
					Not pressed	Battery voltage
141 (BR)	Ground	Trunk request switch	Input	Trunk request switch	ON (pressed)	0V
					OFF (not pressed)	 <p style="text-align: right; font-size: small;">JPMIA0016GB</p> <p style="text-align: center;">1.0V</p>
144 (GR)	Ground	Request switch buzz- er	Output	Request switch buzzer	Sounding	0V
					Not sounding	Battery voltage
147 (L/R)	Ground	Trunk lid opener switch	Input	Trunk lid opener switch	Pressed	0V
					Not pressed	Battery voltage
148 (R/W)	Ground	Rear door RH switch	Input	Rear door RH switch	OFF (when rear door RH closes)	 <p style="text-align: right; font-size: small;">JPMIA0011GB</p> <p style="text-align: center;">11.8V</p>
					ON (when rear door RH opens)	0V

BCM (BODY CONTROL MODULE)

[HALOGEN TYPE]

< ECU DIAGNOSIS >

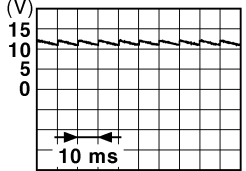
Terminal No. (Wire color)		Description		Condition	Value (Approx.)	
		Signal name	Input/ Output			
(+)	(-)					
149 (R/B)	Ground	Rear door LH switch	Input	Rear door LH switch	OFF (when rear door LH closes)	 <p style="text-align: right; font-size: small;">JPMIA0011GB</p>
				ON (when rear door LH opens)	0V	

- 1 : With low tire pressure monitoring system
- 2 : With electronic steering column lock
- 3 : Early production
- 4 : Without electronic steering column lock

A
B
C
D
E
F
G
H
I
J
K
L
M
N
O
P

EXL

BCM (BODY CONTROL MODULE)

< ECU DIAGNOSIS >

[HALOGEN TYPE]

Wiring Diagram

INFOID:000000005530254

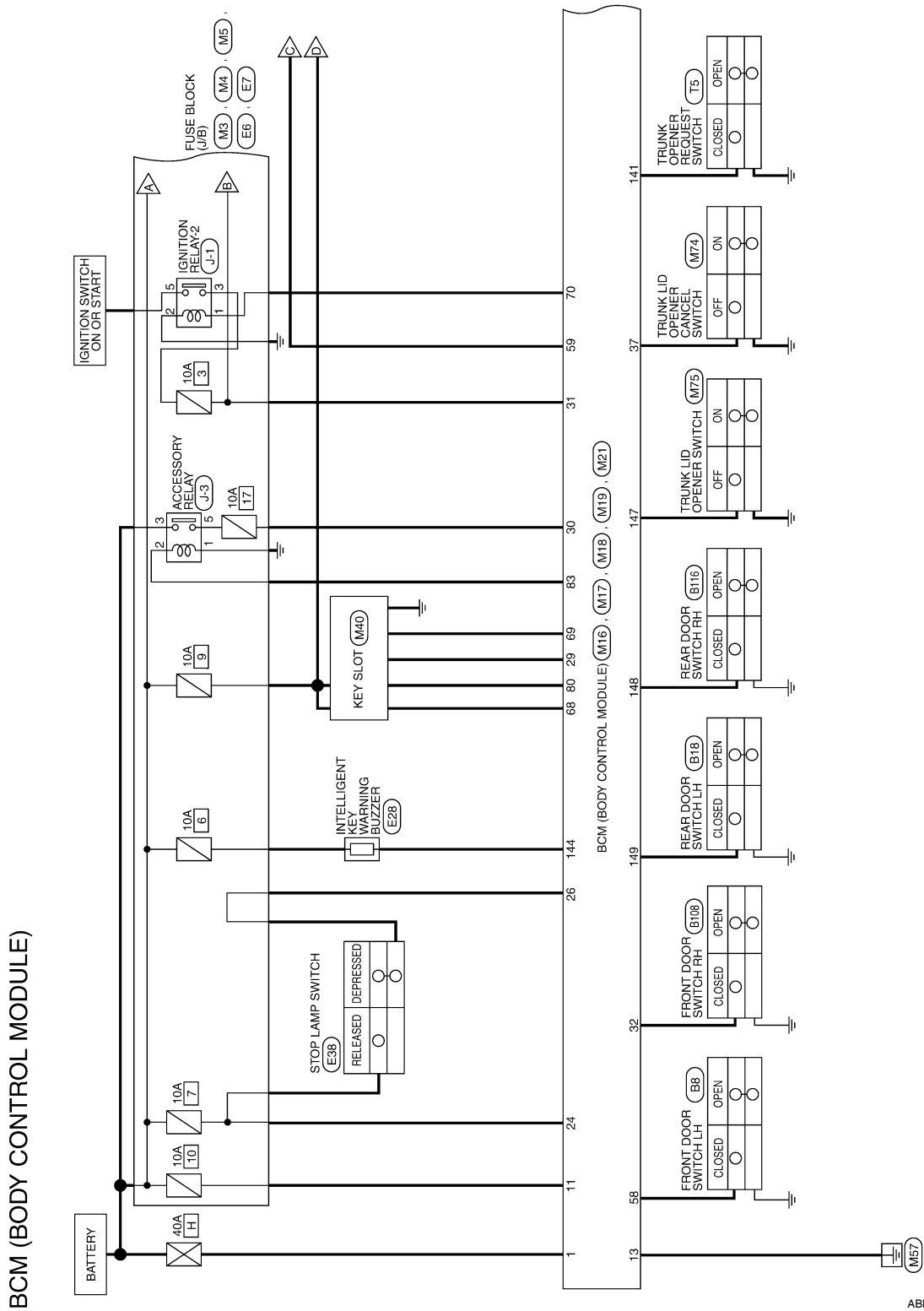

ABMWA0498G

BCM (BODY CONTROL MODULE)

[HALOGEN TYPE]

< ECU DIAGNOSIS >

- ◊TP◊ : WITH LOW TIRE PRESSURE MONITORING SYSTEM
- ◊EH◊ : WITH ELECTRONIC STEERING COLUMN LOCK
- ◊EJ◊ : WITHOUT ELECTRONIC STEERING COLUMN LOCK

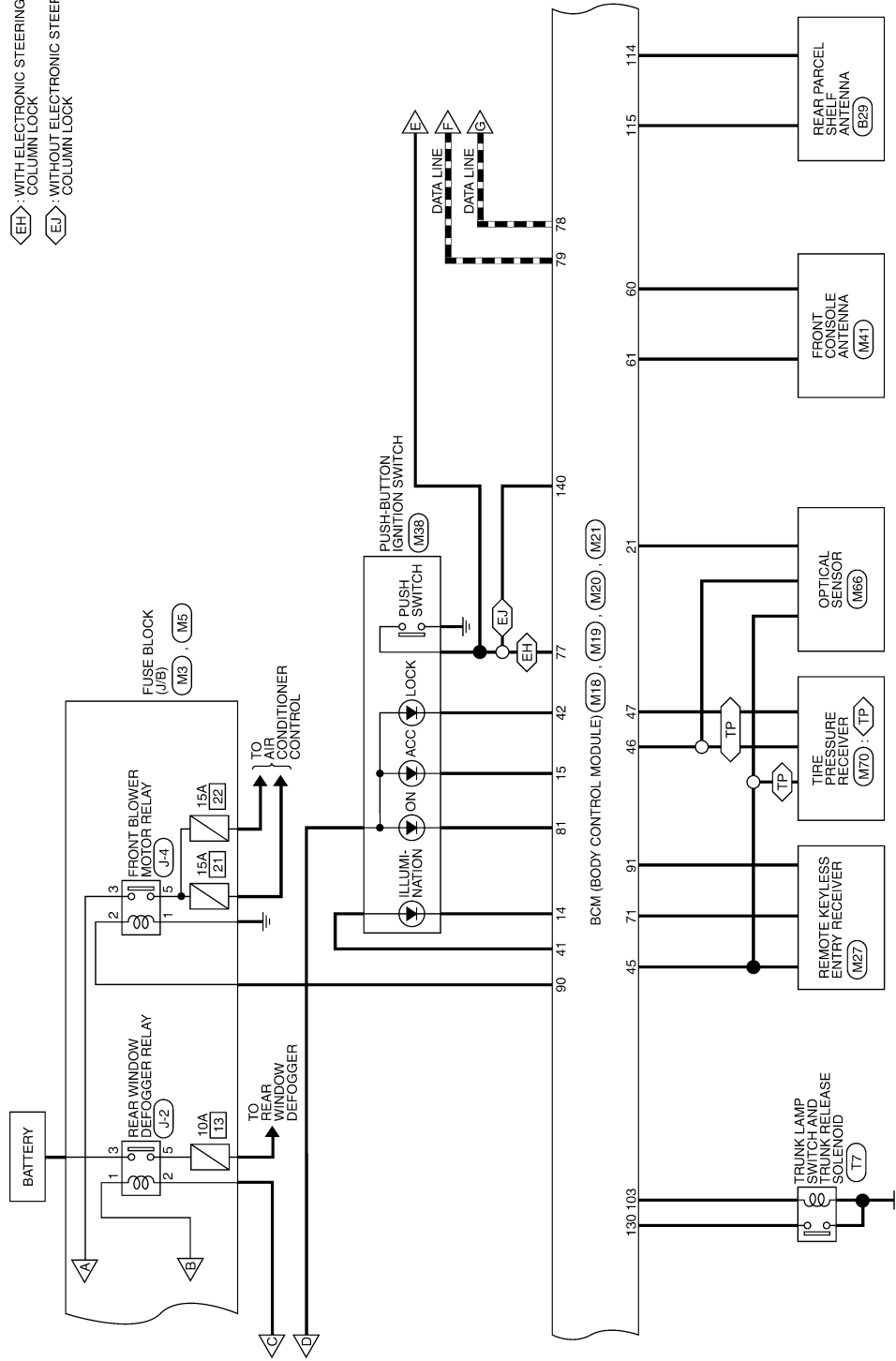

A
B
C
D
E
F
G
H
I
J
K
EXL
M
N
O
P

ABMWA0817GI

BCM (BODY CONTROL MODULE)

< ECU DIAGNOSIS >

[HALOGEN TYPE]

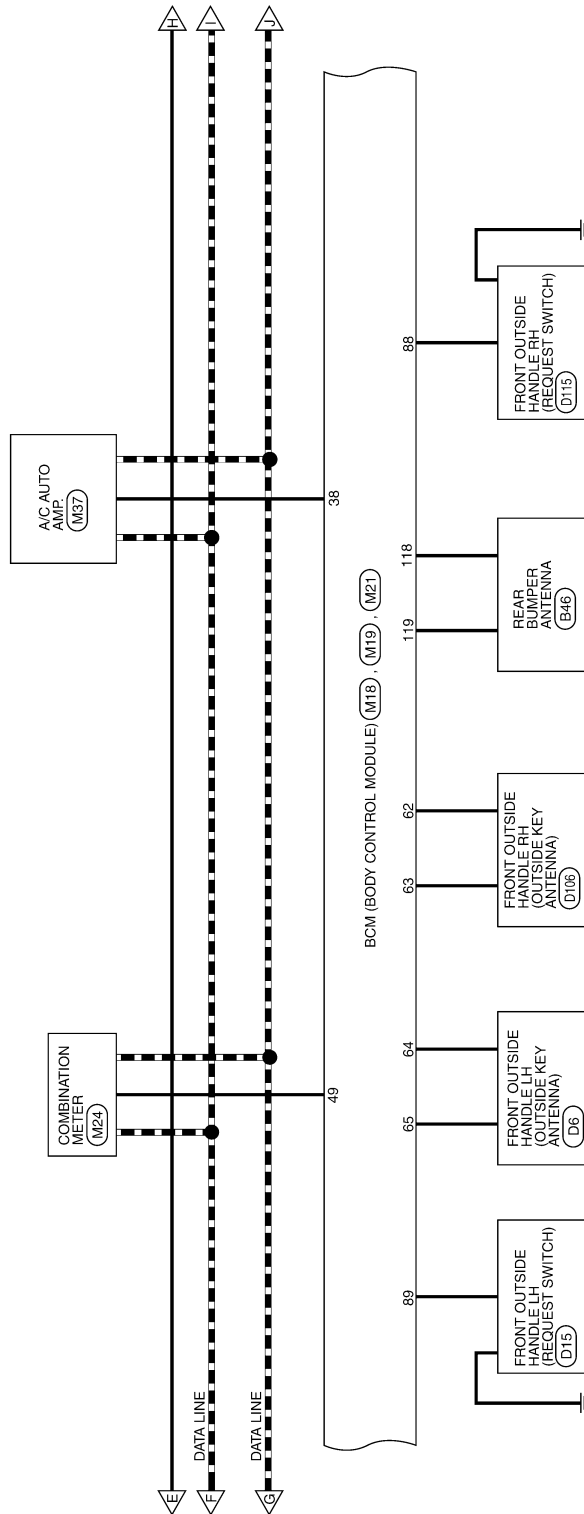

ABMWA0818GI

BCM (BODY CONTROL MODULE)

< ECU DIAGNOSIS >

[HALOGEN TYPE]

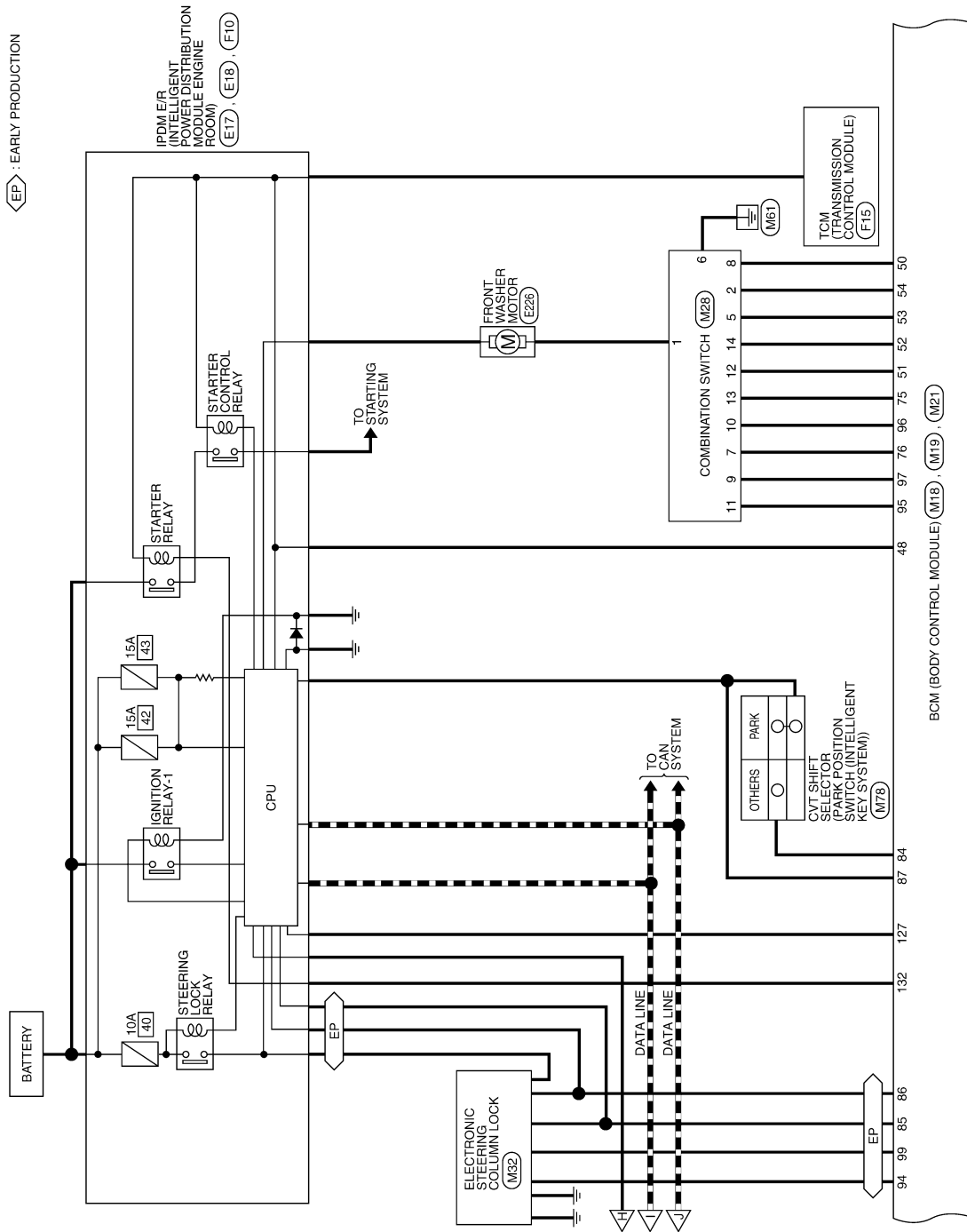

A
B
C
D
E
F
G
H
I
J
K
EXL
M
N
O
P

ABMWA0819GI

BCM (BODY CONTROL MODULE)

[HALOGEN TYPE]

< ECU DIAGNOSIS >

- $\langle A2 \rangle$: WITH LEFT AND RIGHT FRONT POWER WINDOW ANTI-PINCH SYSTEM
- $\langle A3 \rangle$: WITH FRONT AND REAR POWER WINDOW ANTI-PINCH SYSTEM
- $\langle DP \rangle$: WITH DUAL PANEL SUNROOF
- $\langle DW \rangle$: WITHOUT DUAL PANEL SUNROOF

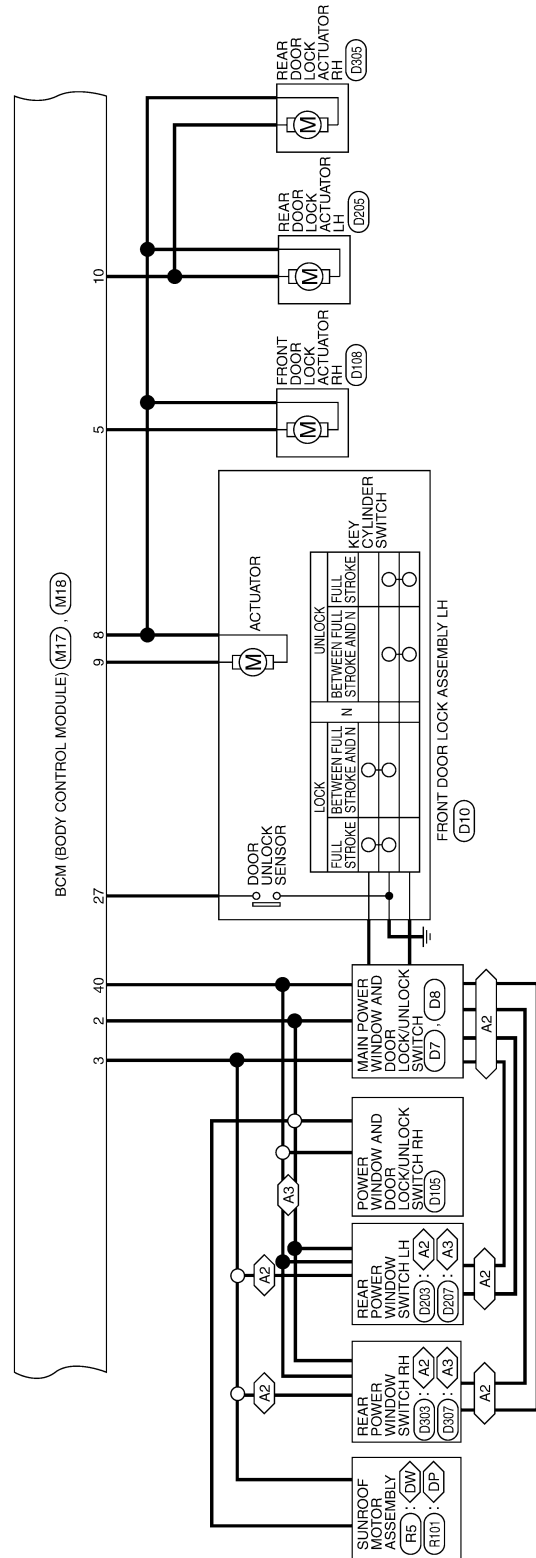

ABMWA0081GI

BCM (BODY CONTROL MODULE)

< ECU DIAGNOSIS >

[HALOGEN TYPE]

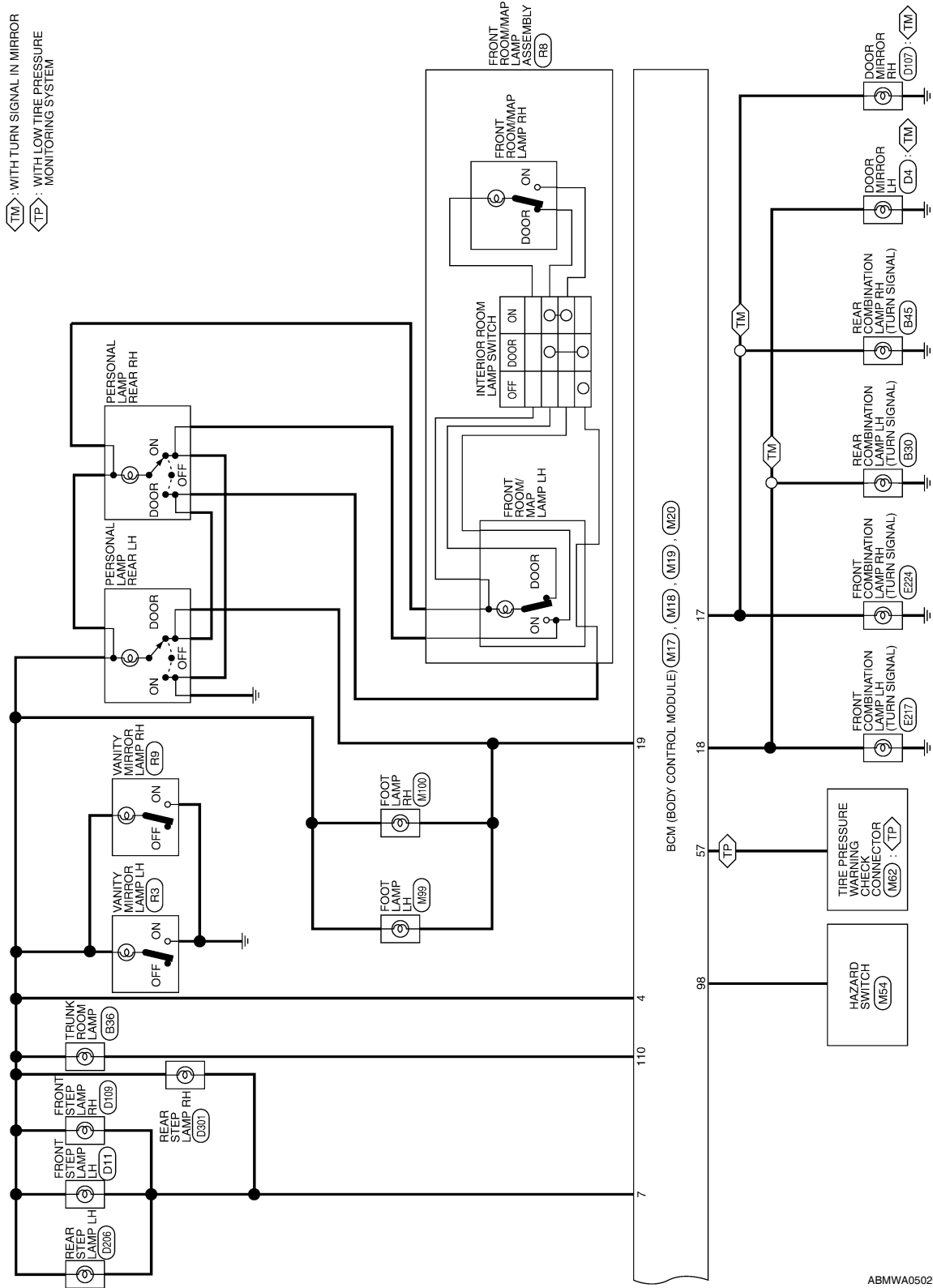

A
B
C
D
E
F
G
H
I
J
K
EXL
M
N
O
P

BCM (BODY CONTROL MODULE)

< ECU DIAGNOSIS >

[HALOGEN TYPE]

BCM (BODY CONTROL MODULE) CONNECTORS

Connector No.	M16
Connector Name	BCM (BODY CONTROL MODULE)
Connector Color	BLACK



Terminal No.	Color of Wire	Signal Name
1	W/B	BATT (F/L)
2	R/Y	P/W POWER SUPPLY PERM
3	L/W	P/W POWER SUPPLY IGN

Connector No.	M17
Connector Name	BCM (BODY CONTROL MODULE)
Connector Color	WHITE

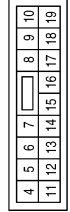

Terminal No.	Color of Wire	Signal Name
4	P/W	R/L POWER SUPPLY
5	G	DOOR UNLOCK OUTPUT AS
6	-	-
7	R/W	STEP LAMP CONT
8	V	DOOR LOCK OUTPUT ALL
9	L	DOOR UNLOCK OUTPUT (DR/FL)

Terminal No.	Color of Wire	Signal Name
10	G	DOOR UNLOCK OUTPUT (RR/RL)
11	Y/R	BAT BCM FUSE
12	-	-
13	B	GND1
14	GR/W	LOW SIDE PUSH LED
15	Y/L	ACC LED
16	-	-
17	G/B	FR FLASHER
18	G/Y	FL FLASHER
19	Y	ROOM LAMP CONT

Connector No.	M18
Connector Name	BCM (BODY CONTROL MODULE)
Connector Color	GREEN

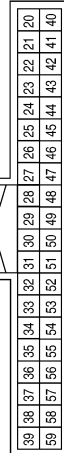

Terminal No.	Color of Wire	Signal Name
20	-	-
21	P/B	A/L SIGNAL TYPE 1
22	-	-
23	-	-
24	R/W	BRAKE SW1
25	-	-
26	O/L	BRAKE SW2

Terminal No.	Color of Wire	Signal Name
27	O	DOOR LOCK STATUS DR
28	-	-
29	Y	FOB IN SW 1
30	V/Y	ACC F/B
31	G	IGN F/B
32	R/B	AS DOOR SW 1
33	-	-
34	-	-
35	-	-
36	-	-
37	O	TRUNK CANCEL SW
38	GR/W	REAR DEFOGGER SW
39	-	-
40	Y/G	PW K-LINE
41	W	RING LED
42	R	S/L LOCK LED
43	-	-
44	-	-

Terminal No.	Color of Wire	Signal Name
45	P	GND RF2 A/L
46	V/W	A/L POWER SUPPLY 5V
47	G/O	RF2 TUNER SIGNAL
48	R/G	SHIFT N/P/ NEUTRAL SW
49	L/O	IMMO LED (SECURITY INDICATOR)
50	LG/B	OUTPUT 5
51	L/W	OUTPUT 1
52	G/B	OUTPUT 2
53	LG/R	OUTPUT 3
54	G/Y	OUTPUT 4
55	-	-
56	-	-
57	W	TPMS MODE
58	SB	DR DOOR SW
59	G/R	REAR DEFOGGER

ABMIA1331GB

BCM (BODY CONTROL MODULE)

< ECU DIAGNOSIS >

[HALOGEN TYPE]

Connector No.	M19
Connector Name	BCM (BODY CONTROL MODULE)
Connector Color	BLACK



79	78	77	76	75	74	73	72	71	70	69	68	67	66	65	64	63	62	61	60
----	----	----	----	----	----	----	----	----	----	----	----	----	----	----	----	----	----	----	----

Terminal No.	Color of Wire	Signal Name
60	B/R	ROOM ANT 2 B
61	W/R	ROOM ANT 2 A
62	V	AS DOOR ANT B
63	P	AS DOOR ANT A
64	V	DR DOOR ANT B
65	P	DR DOOR ANT A
66	-	-

Connector No.	M20
Connector Name	BCM (BODY CONTROL MODULE)
Connector Color	WHITE



100	101	102	103	104
105	106	107	108	109
110	111			

Terminal No.	Color of Wire	Signal Name
100	-	-
101	-	-
102	-	-
103	V	CDL BACK TRUNK

Terminal No.	Color of Wire	Signal Name
67	-	-
68	G/O	FOB READER CLOCK
69	O	FOB READER DATA
70	R/B	IGN REL OUTPUT 2
71	L/O	RF1 TUNER SIGNAL
72	-	-
73	-	-
74	-	-
75	R/Y	INPUT 5
76	R/G	INPUT 3
77	BR	ENG START SW
78	P	CAN-L
79	L	CAN-H
80	R/L	FOB SLOT ILLUMINATION
81	LG	IGN ON LED
82	-	-
83	L	ACC CONT

Terminal No.	Color of Wire	Signal Name
84	Y/R	AT DEVICE OUT
85	L/O	S/L CONDITION 1
86	G/R	S/L CONDITION 2
87	G/B	SHIFT P/ASCD CANCEL SW
88	R	AS REQUEST SW
89	R	DR REQUEST SW
90	Y	BLOWER FAN RELAY
91	L/R	RF POWER SUPPLY 12V
92	-	-
93	-	-
94	G/Y	S/L POWER SUPPLY 12V
95	R/W	INPUT 1
96	P/B	INPUT 4
97	R/B	INPUT 2
98	G/O	HAZARD SW
99	L/Y	S/L K-LINE

Terminal No.	Color of Wire	Signal Name
104	-	-
105	-	-
106	-	-
107	-	-
108	-	-
109	-	-
110	V/W	TRUNK LAMP CONT
111	-	-

A
B
C
D
E
F
G
H
I
J
K
L
M
N
O
P

EXL

BCM (BODY CONTROL MODULE)

< ECU DIAGNOSIS >

[HALOGEN TYPE]

Terminal No.	Color of Wire	Signal Name
136	-	-
137	-	-
138	-	-
139	-	-
140	BR	ENG START SW W/O ESCL
141	BR	TRUNK REQUEST SW
142	-	-
143	-	-
144	GR	BUZZER
145	-	-
146	-	-
147	L/R	BACK TRUNK OPENER
148	R/W	RR DOOR SW
149	R/B	RL DOOR SW
150	-	-
151	-	-

Terminal No.	Color of Wire	Signal Name
119	BR/W	BACK DOOR ANT A
120	-	-
121	-	-
122	-	-
123	-	-
124	-	-
125	-	-
126	-	-
127	BR/W	IGN RELAY OUTPUT
128	-	-
129	-	-
130	W	TRUNK SW
131	-	-
132	R	ST RELAY OUTPUT
133	-	-
134	-	-
135	-	-

Terminal No.	Color of Wire	Signal Name
10	P/B	INPUT 4
11	R/W	INPUT 1
12	L/W	OUTPUT 1
13	R/Y	INPUT 5
14	G/B	OUTPUT 2

Connector No.	M21
Connector Name	BCM (BODY CONTROL MODULE)
Connector Color	GRAY

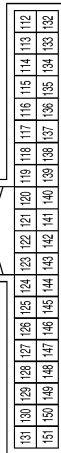

Terminal No.	Color of Wire	Signal Name
112	-	-
113	-	-
114	B	TRUNK ANT 1 B
115	W	TRUNK ANT 1 A
116	-	-
117	-	-
118	L/O	BACK DOOR ANT B

Connector No.	M28
Connector Name	COMBINATION SWITCH
Connector Color	WHITE

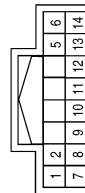

Terminal No.	Color of Wire	Signal Name
1	R/L	-
2	G/Y	OUTPUT 4
5	LG/R	OUTPUT 3
6	B	-
7	R/G	INPUT 3
8	LG/B	OUTPUT 5
9	R/B	INPUT 2

ABMIA2102GB

INFOID:000000005530255

Fail Safe

Display contents of CONSULT	Fail-safe	Cancellation
B2013: ID DISCORD BCM-S/L*	Inhibit engine cranking	Erase DTC
B2014: CHAIN OF S/L-BCM*	Inhibit engine cranking	Erase DTC
B2190: NATS ANTENNA AMP	Inhibit engine cranking	Erase DTC

BCM (BODY CONTROL MODULE)

[HALOGEN TYPE]

< ECU DIAGNOSIS >

Display contents of CONSULT	Fail-safe	Cancellation	
B2191: DIFFERENCE OF KEY	Inhibit engine cranking	Erase DTC	A
B2192: ID DISCORD BCM-ECM	Inhibit engine cranking	Erase DTC	
B2193: CHAIN OF BCM-ECM	Inhibit engine cranking	Erase DTC	B
B2195: ANTI-SCANNING	Inhibit engine cranking	Erase DTC	
B2557: VEHICLE SPEED*	Inhibit electronic steering column lock	When normal vehicle speed signals have been received from ABS actuator and electric unit (control unit) for 500 ms	C
B2560: STARTER CONT RELAY	Inhibit engine cranking	500 ms after the following CAN signal communication status has become consistent <ul style="list-style-type: none"> • Starter control relay signal • Starter relay status signal 	D
B2562: LO VOLTAGE	<ul style="list-style-type: none"> • Inhibit engine cranking • Inhibit electronic steering column lock* 	100 ms after the power supply voltage increases to more than 8.8 V	E
B2601: SHIFT POSITION*	Inhibit electronic steering column lock	500 ms after the following signal reception status becomes consistent <ul style="list-style-type: none"> • Selector lever P position switch signal • P range signal (CAN) 	F
B2602: SHIFT POSITION*	Inhibit electronic steering column lock	5 seconds after the following BCM recognition conditions are fulfilled <ul style="list-style-type: none"> • Ignition switch is in the ON position • Selector lever P position switch signal: Except P position (battery voltage) • Vehicle speed: 4 km/h or more 	G
B2603: SHIFT POSI STATUS*	Inhibit electronic steering column lock	500 ms after the following BCM recognition conditions are fulfilled <ul style="list-style-type: none"> • Ignition switch is in the ON position • Selector lever P position switch signal: Except P position (battery voltage) • Selector lever transmission range switch signal: Except P and N positions (0 V) 	H
B2604: TRANSMISSION RANGE SWITCH*	Inhibit electronic steering column lock	500 ms after any of the following BCM recognition conditions is fulfilled <ul style="list-style-type: none"> • Status 1 <ul style="list-style-type: none"> - Ignition switch is in the ON position - Selector lever transmission range switch signal: P and N position (battery voltage) - P range signal or N range signal (CAN): ON • Status 2 <ul style="list-style-type: none"> - Ignition switch is in the ON position - Selector lever transmission range switch signal: Except P and N positions (0 V) - P range signal and N range signal (CAN): OFF 	I
B2605: TRANSMISSION RANGE SWITCH*	Inhibit electronic steering column lock	500 ms after any of the following BCM recognition conditions is fulfilled <ul style="list-style-type: none"> • Ignition switch is in the ON position - Power position: IGN - Selector lever transmission range switch signal: Except P and N positions (0 V) - Transmission range switch signal (CAN): OFF • Status 2 <ul style="list-style-type: none"> - Ignition switch is in the ON position - Selector lever transmission range switch signal: P or N position (battery voltage) - Transmission range switch signal (CAN): ON 	J
B2606: S/L RELAY*	Inhibit engine cranking	500 ms after the following CAN signal communication status has become consistent <ul style="list-style-type: none"> • Electronic steering column lock relay signal (Request signal) • Electronic steering column lock relay signal (Condition signal) 	K

EXL

BCM (BODY CONTROL MODULE)

[HALOGEN TYPE]

< ECU DIAGNOSIS >

Display contents of CONSULT	Fail-safe	Cancellation
B2607: S/L RELAY*	Inhibit engine cranking	500 ms after the following CAN signal communication status has become consistent <ul style="list-style-type: none"> Electronic steering column lock relay signal (Request signal) Electronic steering column lock relay signal (Condition signal)
B2608: STARTER RELAY	Inhibit engine cranking	500 ms after the following signal communication status becomes consistent <ul style="list-style-type: none"> Starter motor relay control signal Starter relay status signal (CAN)
B2609: S/L STATUS*	<ul style="list-style-type: none"> Inhibit engine cranking Inhibit electronic steering column lock 	When the following electronic steering column lock conditions agree <ul style="list-style-type: none"> BCM electronic steering column lock control status Electronic steering column lock condition No. 1 signal status Electronic steering column lock condition No. 2 signal status
B260A: IGNITION RELAY	Inhibit engine cranking	500 ms after the following conditions are fulfilled <ul style="list-style-type: none"> IGN relay (IPDM E/R) control signal: OFF (Battery voltage) Ignition ON signal (CAN to IPDM E/R): OFF (Request signal) Ignition ON signal (CAN from IPDM E/R): OFF (Condition signal)
B260F: ENG STATE SIG LOST	Maintains the power supply position attained at the time of DTC detection	When any of the following conditions is fulfilled <ul style="list-style-type: none"> Power position changes to ACC Receives engine status signal (CAN)
B2612: S/L STATUS*	<ul style="list-style-type: none"> Inhibit engine cranking Inhibit electronic steering column lock 	When any of the following conditions is fulfilled <ul style="list-style-type: none"> Electronic steering column lock unit status signal (CAN) is received normally The BCM electronic steering column lock control status matches the electronic steering column lock status recognized by the electronic steering column lock unit status signal (CAN from IPDM E/R)
B2617: STARTER RELAY CIRC	Inhibit engine cranking	1 second after the starter motor relay control inside BCM becomes normal
B2618: BCM	Inhibit engine cranking	1 second after the ignition relay (IPDM E/R) control inside BCM becomes normal
B2619: BCM*	Inhibit engine cranking	1 second after the electronic steering column lock unit power supply output control inside BCM becomes normal
B26E1: ENG STATE NO RECIV	Inhibit engine cranking	When any of the following conditions are fulfilled <ul style="list-style-type: none"> Power position changes to ACC Receives engine status signal (CAN)

* : With electronic steering column lock

DTC Inspection Priority Chart

INFOID:000000005530256

If some DTCs are displayed at the same time, perform inspections one by one based on the following priority chart.

Priority	DTC
1	<ul style="list-style-type: none"> B2562: LO VOLTAGE
2	<ul style="list-style-type: none"> U1000: CAN COMM CIRCUIT U1010: CONTROL UNIT (CAN)
3	<ul style="list-style-type: none"> B2190: NATS ANTENNA AMP B2191: DIFFERENCE OF KEY B2192: ID DISCORD BCM-ECM B2193: CHAIN OF BCM-ECM

BCM (BODY CONTROL MODULE)

< ECU DIAGNOSIS >

[HALOGEN TYPE]

Priority	DTC		
4	<ul style="list-style-type: none"> • B2013: ID DISCORD BCM-S/L* • B2014: CHAIN OF S/L-BCM* • B2553: IGNITION RELAY • B2555: STOP LAMP • B2556: PUSH-BTN IGN SW • B2557: VEHICLE SPEED • B2560: STARTER CONT RELAY • B2601: SHIFT POSITION • B2602: SHIFT POSITION • B2603: SHIFT POSI STATUS • B2604: TRANSMISSION RANGE SWITCH • B2605: TRANSMISSION RANGE SWITCH • B2606: S/L RELAY* • B2607: S/L RELAY* • B2608: STARTER RELAY • B2609: S/L STATUS* • B260A: IGNITION RELAY • B260B: STEERING LOCK UNIT* • B260C: STEERING LOCK UNIT* • B260D: STEERING LOCK UNIT* • B260F: ENG STATE SIG LOST • B2612: S/L STATUS* • B2614: ACC RELAY CIRC • B2615: BLOWER RELAY CIRC • B2616: IGN RELAY CIRC • B2617: STARTER RELAY CIRC • B2618: BCM • B2619: BCM* • B261A: PUSH-BTN IGN SW • B26E1: ENG STATE NO RECIV • C1729: VHCL SPEED SIG ERR • U0415: VEHICLE SPEED SIG 	<p style="text-align: center;">A</p> <p style="text-align: center;">B</p> <p style="text-align: center;">C</p> <p style="text-align: center;">D</p> <p style="text-align: center;">E</p> <p style="text-align: center;">F</p> <p style="text-align: center;">G</p> <p style="text-align: center;">H</p> <p style="text-align: center;">I</p> <p style="text-align: center;">J</p>	
	<ul style="list-style-type: none"> • C1704: LOW PRESSURE FL • C1705: LOW PRESSURE FR • C1706: LOW PRESSURE RR • C1707: LOW PRESSURE RL • C1708: [NO DATA] FL • C1709: [NO DATA] FR • C1710: [NO DATA] RR • C1711: [NO DATA] RL • C1712: [CHECKSUM ERR] FL • C1713: [CHECKSUM ERR] FR • C1714: [CHECKSUM ERR] RR • C1715: [CHECKSUM ERR] RL • C1716: [PRESSDATA ERR] FL • C1717: [PRESSDATA ERR] FR • C1718: [PRESSDATA ERR] RR • C1719: [PRESSDATA ERR] RL • C1720: [CODE ERR] FL • C1721: [CODE ERR] FR • C1722: [CODE ERR] RR • C1723: [CODE ERR] RL • C1724: [BATT VOLT LOW] FL • C1725: [BATT VOLT LOW] FR • C1726: [BATT VOLT LOW] RR • C1727: [BATT VOLT LOW] RL • C1734: CONTROL UNIT 	<p style="text-align: center;">K</p> <div style="background-color: black; color: white; text-align: center; padding: 2px;">EXL</div> <p style="text-align: center;">M</p> <p style="text-align: center;">N</p> <p style="text-align: center;">O</p> <p style="text-align: center;">P</p>	
	6	<ul style="list-style-type: none"> • B2622: INSIDE ANTENNA • B2623: INSIDE ANTENNA 	

* : With electronic steering column lock

BCM (BODY CONTROL MODULE)

[HALOGEN TYPE]

< ECU DIAGNOSIS >

DTC Index

INFOID:000000005530257

NOTE:

- Details of time display
- CRNT: Displays when there is a malfunction now or after returning to the normal condition until turning ignition switch OFF → ON again.
- 1 - 39: Displayed if any previous malfunction is present when current condition is normal. It increases 1 → 2 → 3...38 → 39 after returning to the normal condition whenever ignition switch OFF → ON. The counter remains at 39 even if the number of cycles exceeds it. It is counted from 1 again when turning ignition switch OFF → ON after returning to the normal condition if the malfunction is detected again.

CONSULT display	Fail-safe	Intelligent Key warning lamp ON	Tire pressure monitor warning lamp ON	Reference page
No DTC is detected. further testing may be required.	—	—	—	—
U1000: CAN COMM CIRCUIT	—	—	—	BCS-36
U1010: CONTROL UNIT (CAN)	—	—	—	BCS-37
U0415: VEHICLE SPEED SIG	—	—	—	BCS-38
B2013: ID DISCORD BCM-S/L*	×	—	—	SEC-39
B2014: CHAIN OF S/L-BCM*	×	—	—	SEC-40
B2190: NATS ANTENNA AMP	×	—	—	SEC-43
B2191: DIFFERENCE OF KEY	×	—	—	SEC-46
B2192: ID DISCORD BCM-ECM	×	—	—	SEC-47
B2193: CHAIN OF BCM-ECM	×	—	—	SEC-48
B2553: IGNITION RELAY	—	—	—	PCS-55
B2555: STOP LAMP	—	—	—	SEC-49
B2556: PUSH-BTN IGN SW	—	×	—	SEC-52
B2557: VEHICLE SPEED	×	×	—	SEC-54
B2560: STARTER CONT RELAY	×	×	—	SEC-55
B2562: LOW VOLTAGE	—	—	—	BCS-39
B2601: SHIFT POSITION	×	×	—	SEC-56
B2602: SHIFT POSITION	×	×	—	SEC-59
B2603: SHIFT POSI STATUS	×	×	—	SEC-62
B2604: TRANSMISSION RANGE SWITCH	×	×	—	SEC-65
B2605: TRANSMISSION RANGE SWITCH	×	×	—	SEC-67
B2606: S/L RELAY*	×	×	—	SEC-69
B2607: S/L RELAY*	×	×	—	SEC-70
B2608: STARTER RELAY	×	×	—	SEC-72
B2609: S/L STATUS*	×	×	—	SEC-74
B260A: IGNITION RELAY	×	×	—	PCS-57
B260B: STEERING LOCK UNIT*	—	×	—	SEC-78
B260C: STEERING LOCK UNIT*	—	×	—	SEC-79
B260D: STEERING LOCK UNIT*	—	×	—	SEC-80
B260F: ENG STATE SIG LOST	×	×	—	SEC-81
B2612: S/L STATUS*	×	×	—	SEC-83
B2614: ACC RELAY CIRC	—	×	—	PCS-59

BCM (BODY CONTROL MODULE)

< ECU DIAGNOSIS >

[HALOGEN TYPE]

CONSULT display	Fail-safe	Intelligent Key warning lamp ON	Tire pressure monitor warning lamp ON	Reference page	
B2615: BLOWER RELAY CIRC	—	×	—	PCS-62	A
B2616: IGN RELAY CIRC	—	×	—	PCS-65	B
B2617: STARTER RELAY CIRC	×	×	—	PCS-65	
B2618: BCM	×	×	—	PCS-68	C
B2619: BCM*	×	×	—	SEC-89	
B261A: PUSH-BTN IGN SW	—	×	—	SEC-90	
B2622: INSIDE ANTENNA	—	—	—	DLK-60	D
B2623: INSIDE ANTENNA	—	—	—	DLK-63	
B26E1: ENG STATE NO RES	×	×	—	SEC-82	E
C1704: LOW PRESSURE FL	—	—	×	WT-48	
C1705: LOW PRESSURE FR	—	—	×	WT-48	
C1706: LOW PRESSURE RR	—	—	×	WT-48	F
C1707: LOW PRESSURE RL	—	—	×	WT-48	
C1708: [NO DATA] FL	—	—	×	WT-14	
C1709: [NO DATA] FR	—	—	×	WT-14	G
C1710: [NO DATA] RR	—	—	×	WT-14	
C1711: [NO DATA] RL	—	—	×	WT-14	H
C1712: [CHECKSUM ERR] FL	—	—	×	WT-16	
C1713: [CHECKSUM ERR] FR	—	—	×	WT-16	
C1714: [CHECKSUM ERR] RR	—	—	×	WT-16	I
C1715: [CHECKSUM ERR] RL	—	—	×	WT-16	
C1716: [PRESSDATA ERR] FL	—	—	×	WT-18	J
C1717: [PRESSDATA ERR] FR	—	—	×	WT-18	
C1718: [PRESSDATA ERR] RR	—	—	×	WT-18	
C1719: [PRESSDATA ERR] RL	—	—	×	WT-18	K
C1720: [CODE ERR] FL	—	—	×	WT-16	
C1721: [CODE ERR] FR	—	—	×	WT-16	EXL
C1722: [CODE ERR] RR	—	—	×	WT-16	
C1723: [CODE ERR] RL	—	—	×	WT-16	
C1724: [BATT VOLT LOW] FL	—	—	×	WT-16	M
C1725: [BATT VOLT LOW] FR	—	—	×	WT-16	
C1726: [BATT VOLT LOW] RR	—	—	×	WT-16	
C1727: [BATT VOLT LOW] RL	—	—	×	WT-16	N
C1729: VHCL SPEED SIG ERR	—	—	×	WT-20	
C1734: CONTROL UNIT	—	—	×	WT-21	O

* : With electronic steering column lock

IPDM E/R (INTELLIGENT POWER DISTRIBUTION MODULE ENGINE ROOM)

< ECU DIAGNOSIS >

[HALOGEN TYPE]

IPDM E/R (INTELLIGENT POWER DISTRIBUTION MODULE ENGINE ROOM)

Reference Value

INFOID:000000005530270

VALUES ON THE DIAGNOSIS TOOL

Monitor Item	Condition		Value/Status
MOTOR FAN REQ	Engine idle speed	Changes depending on engine coolant temperature, air conditioner operation status, vehicle speed, etc.	1,2,3,4
AC COMP REQ	Engine running	A/C switch OFF	Off
		A/C switch ON (Compressor is operating)	On
TAIL&CLR REQ	Lighting switch OFF		Off
	Lighting switch 1ST, 2ND, HI or AUTO (Light is illuminated)		On
HL LO REQ	Lighting switch OFF		Off
	Lighting switch 2ND HI or AUTO (Light is illuminated)		On
HL HI REQ	Lighting switch OFF		Off
	Lighting switch HI		On
FR FOG REQ	Lighting switch 2ND or AUTO (Light is illuminated)	Front fog lamp switch OFF	Off
		<ul style="list-style-type: none"> • Front fog lamp switch ON • Daytime running light activated (Only for Canada models) 	On
FR WIP REQ	Ignition switch ON	Front wiper switch OFF	STOP
		Front wiper switch INT	1LOW
		Front wiper switch LO	Low
		Front wiper switch HI	Hi
WIP AUTO STOP	Ignition switch ON	Front wiper stop position	STOP P
		Any position other than front wiper stop position	ACT P
WIP PROT	Ignition switch ON	Front wiper operates normally	Off
		Front wiper stops at fail-safe operation	BLOCK
IGN RLY1 -REQ	Ignition switch OFF or ACC		Off
	Ignition switch ON		On
IGN RLY	Ignition switch OFF or ACC		Off
	Ignition switch ON		On
PUSH SW	Release the push-button ignition switch		Off
	Press the push-button ignition switch		On
INTER/NP SW	Ignition switch ON	CVT selector lever in any position other than P or N	Off
	Ignition switch ON	CVT selector lever in P or N position	On
ST RLY CONT	Ignition switch ON		Off
	At engine cranking		On
IHBT RLY -REQ	Ignition switch ON		Off
	At engine cranking		On

IPDM E/R (INTELLIGENT POWER DISTRIBUTION MODULE ENGINE ROOM)

< ECU DIAGNOSIS >

[HALOGEN TYPE]

Monitor Item	Condition	Value/Status
ST/INHI RLY	Ignition switch ON	Off
	At engine cranking	ST →INHI
	The status of starter relay or starter control relay cannot be recognized by the battery voltage malfunction, etc. when the starter relay is ON and the starter control relay is OFF	UNKWN
DETENT SW	Ignition switch ON <ul style="list-style-type: none"> • Press the selector button with CVT selector lever in P position • CVT selector lever in any position other than P 	Off
	Release the CVT selector button with CVT selector lever in P position	On
S/L RLY -REQ ¹	None of the conditions below are present	Off
	<ul style="list-style-type: none"> • Open the driver door after the ignition switch is turned OFF (for a few seconds) • Press the push-button ignition switch when the steering lock is activated 	On
S/L STATE ¹	Steering lock is activated	LOCK
	Steering lock is deactivated	UNLK
	[DTC B210A] is detected	UNKWN
DTRL -REQ	DTRL ON	On
	DTRL OFF	Off
OIL P SW	Ignition switch OFF, ACC or engine running	Open
	Ignition switch ON	Close
THFT HRN REQ	Not operated	Off
	<ul style="list-style-type: none"> • Panic alarm is activated • Horn is activated with VEHICLE SECURITY (THEFT WARNING) SYSTEM 	On
HORN CHIRP	Not operated	Off
	Door locking with Intelligent Key (horn chirp mode)	On

1: Early production

A
B
C
D
E
F
G
H
I
J
K

EXL

M
N
O
P

IPDM E/R (INTELLIGENT POWER DISTRIBUTION MODULE ENGINE ROOM)

< ECU DIAGNOSIS >

[HALOGEN TYPE]

TERMINAL LAYOUT

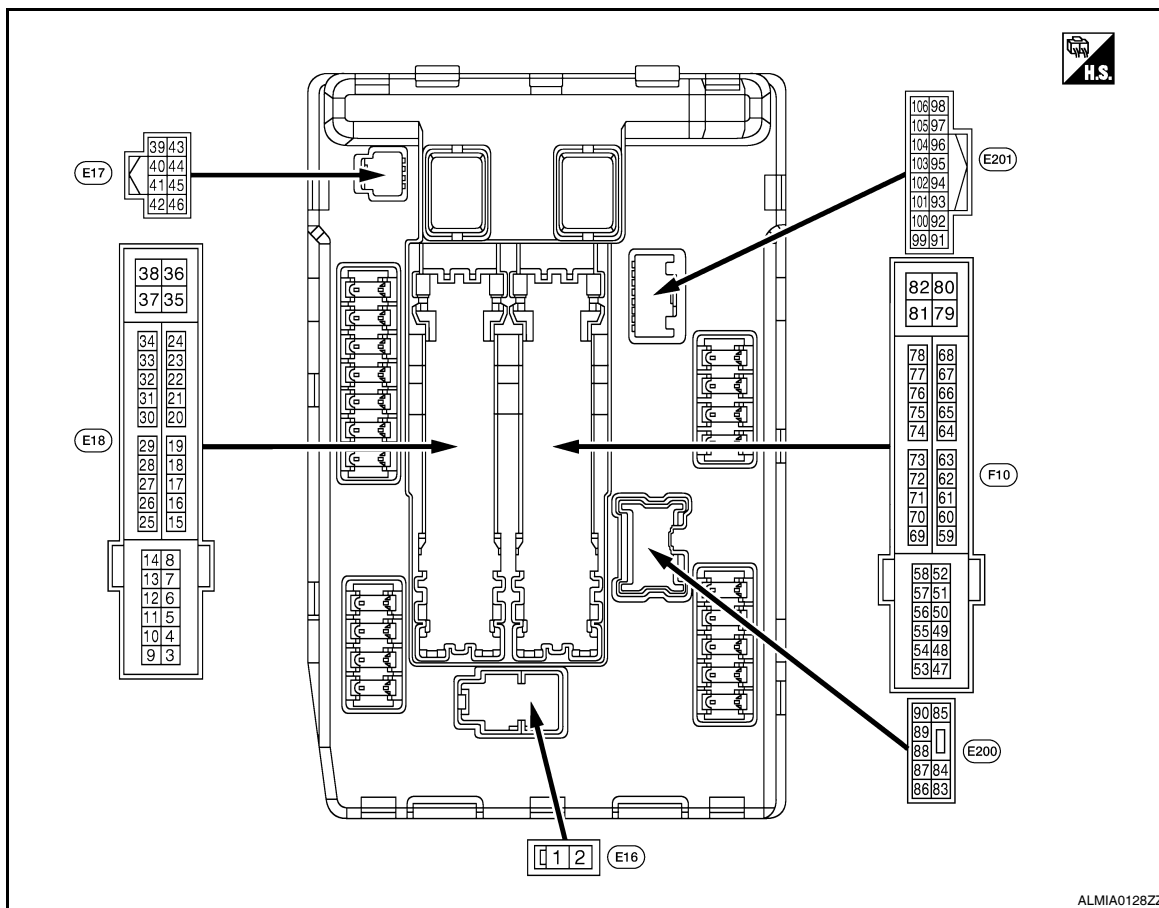

PHYSICAL VALUES

Terminal No. (Wire color)		Description		Condition		Value (Approx.)
+	-	Signal name	Input/ Output			
1 (R)	Ground	Battery power supply	Input	Ignition switch OFF		Battery voltage
2 (L)	Ground	Battery power supply	Input	Ignition switch OFF		Battery voltage
4 (LG)	Ground	Front wiper LO	Output	Ignition switch OFF	Front wiper switch OFF	0 V
				Ignition switch ON	Front wiper switch LO	Battery voltage
5 (Y)	Ground	Front wiper HI	Output	Ignition switch OFF	Front wiper switch OFF	0 V
				Ignition switch ON	Front wiper switch HI	Battery voltage
6 (L)	Ground	Daytime light relay power supply (Canada models only)	Output	Ignition switch OFF		Battery voltage
7 (GR)	Ground	Tail, license plate lamps & interior lamps	Output	Ignition switch OFF	Lighting switch OFF	0 V
				Ignition switch ON	Lighting switch 1ST	Battery voltage
10 (BR)	Ground	ECM relay power supply	Output	Ignition switch OFF (For a few seconds after turning ignition switch OFF)		0 V
				<ul style="list-style-type: none"> Ignition switch ON Ignition switch OFF (More than a few seconds after turning ignition switch OFF) 		Battery voltage

IPDM E/R (INTELLIGENT POWER DISTRIBUTION MODULE ENGINE ROOM)

< ECU DIAGNOSIS >

[HALOGEN TYPE]

Terminal No. (Wire color)		Description		Condition		Value (Approx.)	
11 ¹ (O)	Ground	Electronic steering column lock power supply	Output	Ignition switch OFF	A few seconds after opening the driver door	Battery voltage	A
				Ignition switch LOCK	Press the push-button ignition switch	Battery voltage	B
				Ignition switch ACC or ON		0 V	C
12 (B)	Ground	Ground	—	Ignition switch ON		0 V	D
13 (SB)	Ground	Fuel pump power supply	Output	Approximately 1 second or more after turning the ignition switch ON		0 V	E
				<ul style="list-style-type: none"> • Approximately 1 second after turning the ignition switch ON • Engine running 		Battery voltage	F
15 (W)	Ground	Ignition relay-1 power supply	Output	Ignition switch OFF		0 V	G
				Ignition switch ON		Battery voltage	H
16 (R)	Ground	Front wiper auto stop	Input	Ignition switch ON	Front wiper stop position	0 V	I
					Any position other than front wiper stop position	Battery voltage	J
19 (Y)	Ground	Ignition relay-1 power supply	Output	Ignition switch OFF		0 V	K
				Ignition switch ON		Battery voltage	EXL
20 (L)	Ground	Ambient sensor ground	—	Ignition switch ON		0V	M
21 (LG)	Ground	Ambient sensor	—	Ignition switch ON		5V	N
22 (SB)	Ground	Refrigerant pressure sensor ground	—	Ignition switch ON		0V	O
23 (GR)	Ground	Refrigerant pressure sensor	—	<ul style="list-style-type: none"> • Ignition switch ON (READY) • Both A/C switch and blower motor switch ON (electric compressor operates) 		1.0 - 4.0V	P
24 (G)	Ground	Refrigerant pressure sensor power supply	—	Ignition switch ON		5V	
25 (GR)	Ground	Ignition relay-1 power supply	Output	Ignition switch OFF		0 V	
				Ignition switch ON		Battery voltage	
27 (W)	Ground	Ignition relay monitor	Input	Ignition switch OFF or ACC		Battery voltage	
				Ignition switch ON		0 V	
28 (SB)	Ground	Push-button ignition switch	Input	Press the push-button ignition switch		0 V	
				Release the push-button ignition switch		Battery voltage	
30 (BR)	Ground	Starter relay control	Input	CVT selector lever in any position other than P or N (ignition switch ON)		0 V	
				CVT selector lever P or N (ignition switch ON)		Battery voltage	
32 ¹ (P)	Ground	Electronic steering column lock unit condition-1	Input	Electronic steering column lock is activated		0 V	
				Electronic steering column lock is deactivated		Battery voltage	

IPDM E/R (INTELLIGENT POWER DISTRIBUTION MODULE ENGINE ROOM)

< ECU DIAGNOSIS >

[HALOGEN TYPE]

Terminal No. (Wire color)		Description		Condition		Value (Approx.)
+	-	Signal name	Input/ Output			
33 ¹ (G)	Ground	Electronic steering column lock condition-2	Input	Electronic steering column lock is activated		Battery voltage
				Electronic steering column lock is deactivated		0 V
34 (O)	Ground	Cooling fan relay-3 control	Input	Ignition switch OFF or ACC		0 V
				Ignition switch ON		0.7 V
35 (P)	Ground	Cooling fan motor control	Output	Ignition switch OFF or ACC		0 V
				Ignition switch ON		0.7 V
36 (G)	Ground	Battery power supply	Input	Ignition switch OFF		Battery voltage
38 (GR)	Ground	Cooling fan motor control	Output	Ignition switch OFF or ACC		0 V
				Ignition switch ON		0.7 V
39 (P)	—	CAN - L	Input/ Output	—		—
40 (L)	—	CAN - H	Input/ Output	—		—
41 (B)	Ground	Ground	—	Ignition switch ON		0 V
42 (SB)	Ground	Cooling fan relay-2 control	Input	Ignition switch OFF or ACC		0 V
				Ignition switch ON		0.7 V
43 (Y)	Ground	CVT shift selector (Detention switch)	Input	Ignition switch ON	Press the CVT selector button (CVT selector lever P)	Battery voltage
					<ul style="list-style-type: none"> • CVT selector lever in any position other than P • Release the CVT selector button (CVT selector lever P) 	0 V
44 (W)	Ground	Horn relay control	Input	The horn is deactivated		Battery voltage
				The horn is activated		0 V
45 (GR)	Ground	Anti theft horn relay control	Input	The horn is deactivated		Battery voltage
				The horn is activated		0 V
46 (BR)	Ground	Starter relay control	Input	CVT selector lever in any position other than P or N (ignition switch ON)		0 V
				CVT selector lever P or N (ignition switch ON)		Battery voltage
48 (W)	Ground	A/C relay power supply	Output	Engine running	A/C switch OFF	0 V
					A/C switch ON (A/C compressor is operating)	Battery voltage
49 (R/G)	Ground	ECM relay power supply	Output	Ignition switch OFF (For a few seconds after turning ignition switch OFF)		0 V
				<ul style="list-style-type: none"> • Ignition switch ON • Ignition switch OFF (More than a few seconds after turning ignition switch OFF) 		Battery voltage
51 (LG)	Ground	Ignition relay power supply	Output	Ignition switch OFF		0 V
				Ignition switch ON		Battery voltage

IPDM E/R (INTELLIGENT POWER DISTRIBUTION MODULE ENGINE ROOM)

< ECU DIAGNOSIS >

[HALOGEN TYPE]

Terminal No. (Wire color)		Description		Condition		Value (Approx.)	
52 (Y/G)	Ground	Ignition relay power supply	Output	Ignition switch OFF		0 V	A
				Ignition switch ON		Battery voltage	B
53 (R/W)	Ground	ECM relay power supply	Output	Ignition switch OFF (For a few seconds after turning ignition switch OFF)		0 V	C
				<ul style="list-style-type: none"> • Ignition switch ON • Ignition switch OFF (More than a few seconds after turning ignition switch OFF) 		Battery voltage	D
54 (G/W)	Ground	Throttle control motor relay power supply	Output	Ignition switch OFF (For a few seconds after turning ignition switch OFF)		0 V	E
				<ul style="list-style-type: none"> • Ignition switch ON • Ignition switch OFF (More than a few seconds after turning ignition switch OFF) 		Battery voltage	F
55 (W/L)	Ground	ECM power supply	Output	Ignition switch OFF		Battery voltage	G
56 (R/Y)	Ground	Ignition relay power supply	Output	Ignition switch OFF		0 V	H
				Ignition switch ON		Battery voltage	
57 (O)	Ground	Ignition relay power supply	Output	Ignition switch OFF		0 V	I
				Ignition switch ON		Battery voltage	
58 (Y)	Ground	Ignition relay power supply	Output	Ignition switch OFF		0 V	J
				Ignition switch ON		Battery voltage	
69 (W/B)	Ground	ECM relay control	Output	Ignition switch OFF (For a few seconds after turning ignition switch OFF)		Battery voltage	K
				<ul style="list-style-type: none"> • Ignition switch ON • Ignition switch OFF (More than a few seconds after turning ignition switch OFF) 		0 - 1.5 V	
70 (O)	Ground	Throttle control motor relay control	Output	Ignition switch ON → OFF		0 - 1.0 V ↓ Battery voltage ↓ 0 V	M
				Ignition switch ON		0 - 1.0 V	
72 (R/B)	Ground	Transmission range switch signal	Input	Ignition switch ON	CVT selector lever in P or N position	Battery voltage	N
					CVT selector lever in any position other than P or N position	0 V	
75 (LG)	Ground	Oil pressure switch	Input	Ignition switch ON	Engine stopped	0 V	O
					Engine running	Battery voltage	

EXL

IPDM E/R (INTELLIGENT POWER DISTRIBUTION MODULE ENGINE ROOM)

< ECU DIAGNOSIS >

[HALOGEN TYPE]

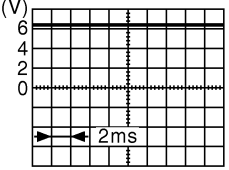
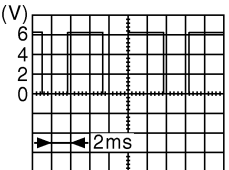
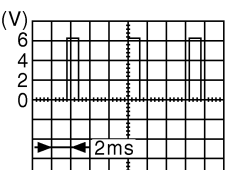
Terminal No. (Wire color)		Description		Condition		Value (Approx.)
+	-					
76 (SB)	Ground	Power generation command signal	Output	Ignition switch ON		 <small>JPMIA0001GB</small> 6.3 V
				40% is set on "Active test", "ALTERNATOR DUTY" of "ENGINE"		 <small>JPMIA0002GB</small> 3.8 V
				80% is set on "Active test", "ALTERNATOR DUTY" of "ENGINE"		 <small>JPMIA0003GB</small> 1.4 V
77 (GR)	Ground	Fuel pump relay control	Output	<ul style="list-style-type: none"> • Approximately 1 second after turning the ignition switch ON • Engine running 		0 - 1.0 V
				Approximately 1 second or more after turning the ignition switch ON		Battery voltage
80 (B/W)	Ground	Starter motor	Output	At engine cranking		Battery voltage
83 (R/Y)	Ground	Headlamp LO (RH)	Output	Ignition switch ON	Lighting switch OFF	0 V
					Lighting switch 2ND	Battery voltage
84 (L)	Ground	Headlamp LO (LH)	Output	Ignition switch ON	Lighting switch OFF	0 V
					Lighting switch 2ND	Battery voltage
86 (W/R)	Ground	Front fog lamp (RH)	Output	Lighting switch 2ND	<ul style="list-style-type: none"> • Front fog lamp switch ON • Daytime running light activated (Only for Canada models) 	Battery voltage
					Front fog lamp switch OFF	0 V
87 (L/Y)	Ground	Front fog lamp (LH)	Output	Lighting switch 2ND	<ul style="list-style-type: none"> • Front fog lamp switch ON • Daytime running light activated (Only for Canada models) 	Battery voltage
					Front fog lamp switch OFF	0 V
88 (R/W)	Ground	Washer pump power supply	Output	Ignition switch ON		Battery voltage

IPDM E/R (INTELLIGENT POWER DISTRIBUTION MODULE ENGINE ROOM)

< ECU DIAGNOSIS >

[HALOGEN TYPE]

Terminal No. (Wire color)		Description		Condition		Value (Approx.)
+	-	Signal name	Input/ Output			
89 (L/W)	Ground	Headlamp HI (RH)	Output	Ignition switch ON	• Lighting switch HI • Lighting switch PASS	Battery voltage
					Lighting switch OFF	0 V
90 (G)	Ground	Headlamp HI (LH)	Output	Ignition switch ON	• Lighting switch HI • Lighting switch PASS	Battery voltage
					Lighting switch OFF	0 V
91 (LG/ R)	Ground	Parking lamp (RH)	Output	Ignition switch ON	Lighting switch 1ST	Battery voltage
					Lighting switch OFF	0 V
92 (LG/ B)	Ground	Parking lamp (LH)	Output	Ignition switch ON	Lighting switch 1ST	Battery voltage
					Lighting switch OFF	0 V
99 (BR/ W)	Ground	Ambient sensor ground	—	Ignition switch ON		0V
100 (SB)	Ground	Ambient sensor	—	Ignition switch ON		5V
101 (W)	Ground	Refrigerant pressure sensor ground	—	Ignition switch ON		0V
102 (R)	Ground	Refrigerant pressure sensor	—	• Ignition switch ON (READY) • Both A/C switch and blower motor switch ON (electric compressor operates)		1.0 - 4.0V
103 (P)	Ground	Refrigerant pressure sensor power supply	—	Ignition switch ON		5V
105 (V)	Ground	Daytime light relay control (Only for Canada models)	Output	Ignition switch ON	Daytime light system active	Battery voltage
				Ignition switch ON	Daytime light system inactive	0 V

1: Early production

A
B
C
D
E
F
G
H
I
J
K
L
M
N
O
P

EXL

IPDM E/R (INTELLIGENT POWER DISTRIBUTION MODULE ENGINE ROOM)

< ECU DIAGNOSIS >

[HALOGEN TYPE]

Wiring Diagram

INFOID:000000005530271

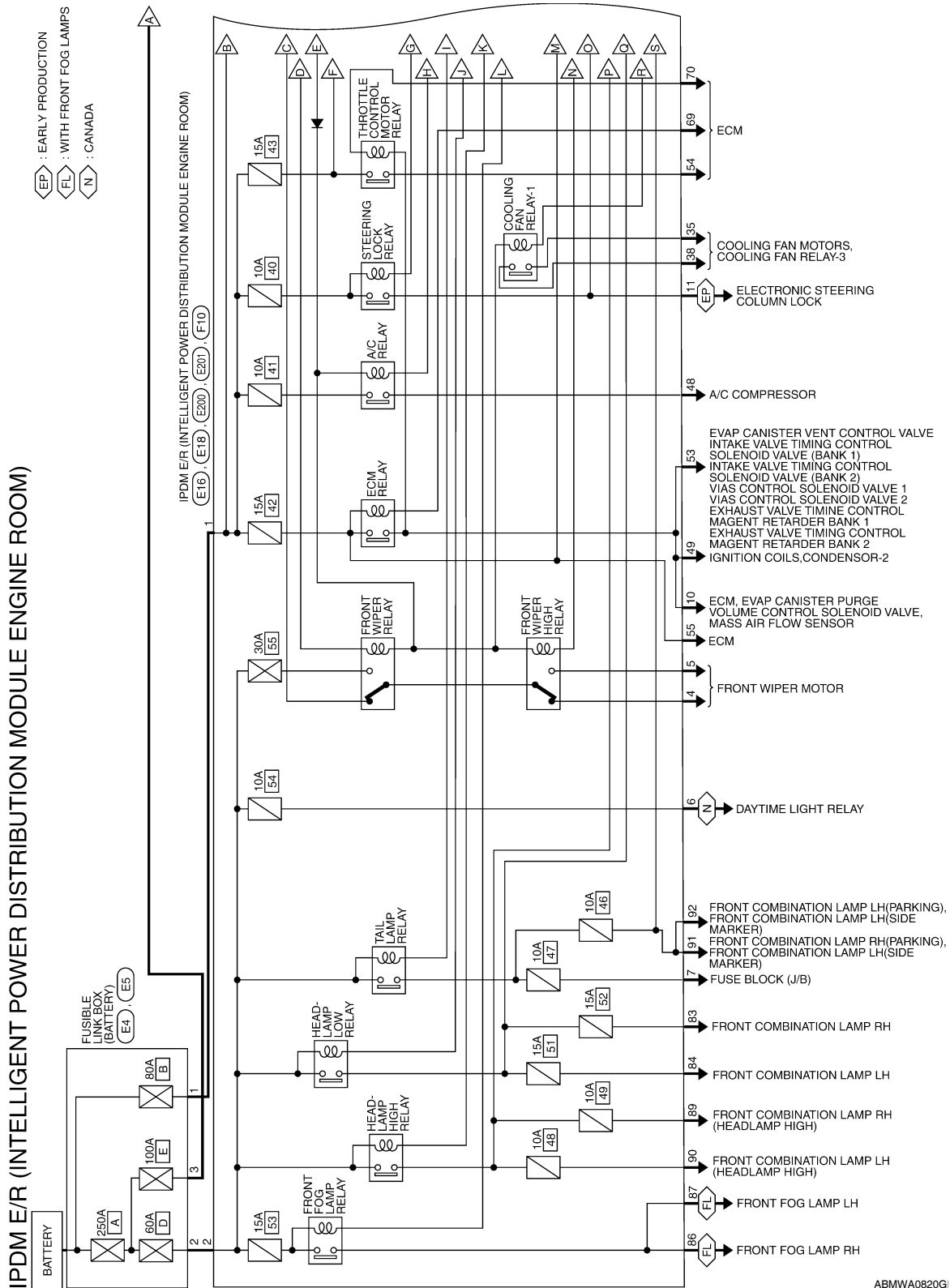

ABMWA0820G

IPDM E/R (INTELLIGENT POWER DISTRIBUTION MODULE ENGINE ROOM)

< ECU DIAGNOSIS >

[HALOGEN TYPE]

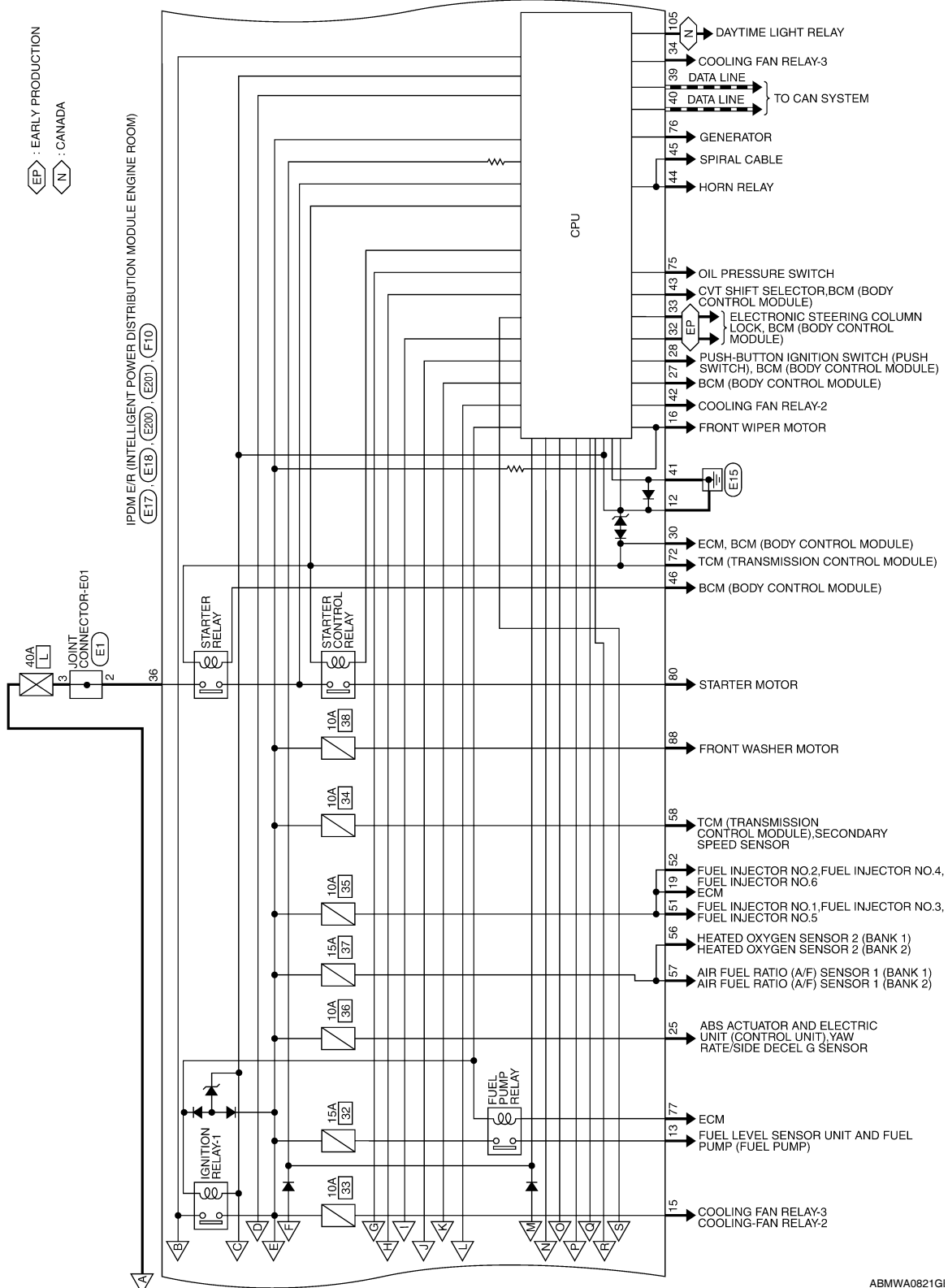

A
B
C
D
E
F
G
H
I
J
K
L
M
N
O
P

EXL

ABMWA0821GI

IPDM E/R (INTELLIGENT POWER DISTRIBUTION MODULE ENGINE ROOM)

< ECU DIAGNOSIS >

[HALOGEN TYPE]

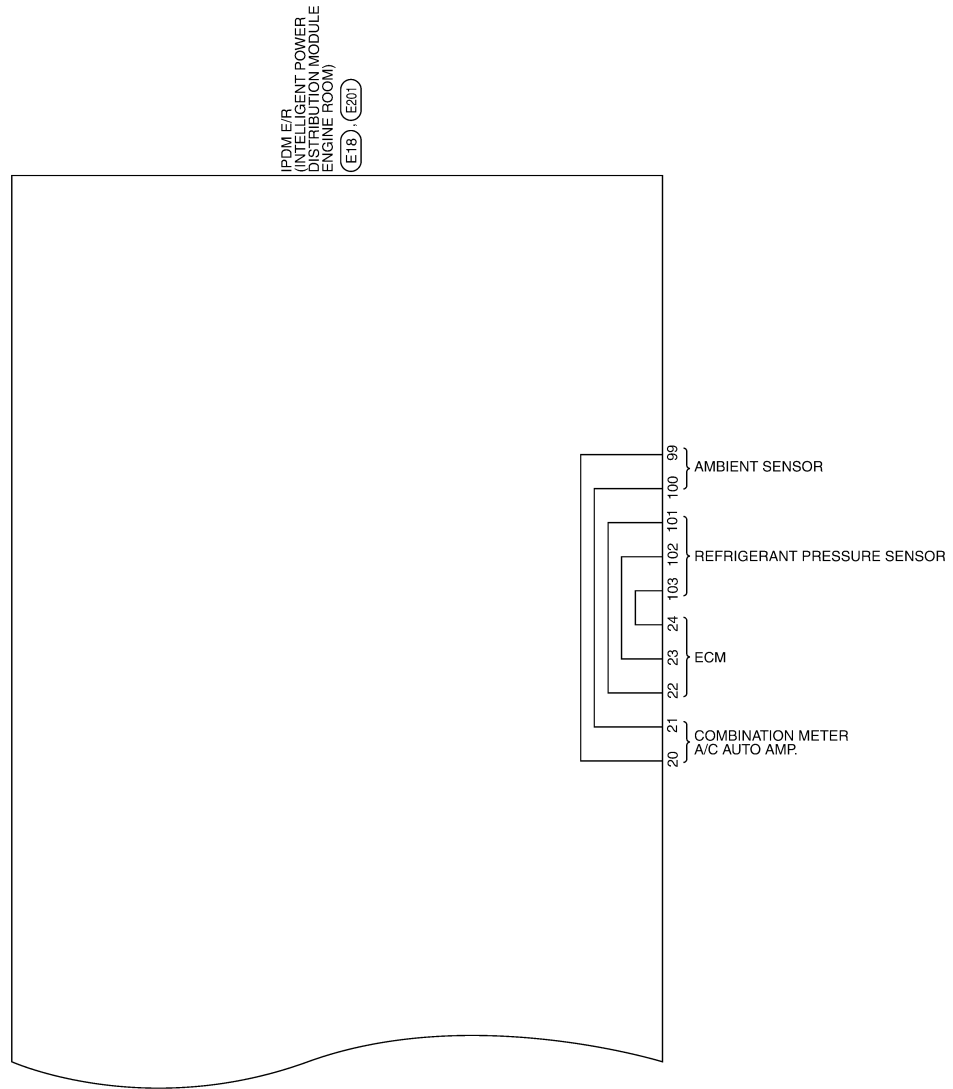

ABMWA0085GI

IPDM E/R (INTELLIGENT POWER DISTRIBUTION MODULE ENGINE ROOM) CONNECTORS

Connector No.	E1
Connector Name	JOINT CONNECTOR-E01
Connector Color	WHITE



Terminal No.	Color of Wire	Signal Name
2	G	-
3	G	-

Connector No.	E4
Connector Name	FUSIBLE LINK BOX (BATTERY)
Connector Color	BROWN



Terminal No.	Color of Wire	Signal Name
1	B/W	-
2	L	-

Connector No.	E5
Connector Name	FUSIBLE LINK BOX (BATTERY)
Connector Color	GRAY



Terminal No.	Color of Wire	Signal Name
3	R	-

Connector No.	E16
Connector Name	IPDM E/R (INTELLIGENT POWER DISTRIBUTION MODULE ENGINE ROOM)
Connector Color	BLACK



Terminal No.	Color of Wire	Signal Name
1	R	F/L MAIN
2	L	F/L USM

Connector No.	E17
Connector Name	IPDM E/R (INTELLIGENT POWER DISTRIBUTION MODULE ENGINE ROOM)
Connector Color	WHITE

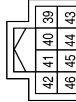

Terminal No.	Color of Wire	Signal Name
39	P	CAN-L
40	L	CAN-H
41	B	GND (SIGNAL)
42	SB	MOTOR FAN RLY MID
43	Y	DETENT SW
44	W	HORN RLY
45	GR	HORN SW
46	BR	START CONT

A
B
C
D
E
F
G
H
I
J
K
L
M
N
O
P

EXL

IPDM E/R (INTELLIGENT POWER DISTRIBUTION MODULE ENGINE ROOM)

< ECU DIAGNOSIS >

[HALOGEN TYPE]

Connector No.	E18
Connector Name	IPDM E/R (INTELLIGENT POWER DISTRIBUTION MODULE ENGINE ROOM)
Connector Color	WHITE

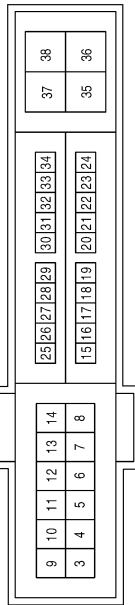

Terminal No.	Color of Wire	Signal Name
3	-	-
4	LG	FR WIPER LO
5	Y	FR WIPER HI
6	L	DTRL/DEICER

Connector No.	E200
Connector Name	IPDM E/R (INTELLIGENT POWER DISTRIBUTION MODULE ENGINE ROOM)
Connector Color	WHITE

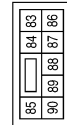

Terminal No.	Color of Wire	Signal Name
83	R/Y	HEADLAMP LO RH
84	L	HEADLAMP LO LH
85	-	-
86	W/R	FR FOG LAMP RH
87	L/Y	FR FOG LAMP LH
88	R/W	WASHER MTR
89	L/W	HEADLAMP HI RH
90	G	HEADLAMP HI LH

Terminal No.	Color of Wire	Signal Name
7	GR	TAIL/ILLUMI
8	-	-
9	-	-
10	BR	ECM VB
11	O	ESCL (EARLY PRODUCTION)
12	B	GND (POWER)
13	SB	FUEL PUMP
14	-	-
15	W	START IG E/R
16	R	WIPER AUTOSTOP
17	-	-
18	-	-
19	Y	BCM IGNSW
20	L	AMB SENS GND-E/R
21	LG	AMB SENS SIG-E/R
22	SB	PD SENS GND-E/R
23	GR	PD SENS SIG-E/R

Terminal No.	Color of Wire	Signal Name
24	G	PD SENS PWR-E/R
25	GR	ABS ECU
26	-	-
27	W	IGN SIGNAL
28	SB	PUSH START SW
29	-	-
30	BR	CLUTCH I/L SW
31	-	-
32	P	SL CONDITION 1 (EARLY PRODUCTION)
33	G	SL CONDITION 2 (EARLY PRODUCTION)
34	O	MOTOR FAN RLY HI
35	P	MOTOR FAN LO
36	G	F/L IGNSW
37	-	-
38	GR	F/L MOTOR FAN

Connector No.	E201
Connector Name	IPDM E/R (INTELLIGENT POWER DISTRIBUTION MODULE ENGINE ROOM)
Connector Color	WHITE

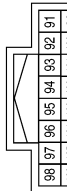

Terminal No.	Color of Wire	Signal Name
91	LG/R	CLEARANCE RH
92	LG/B	CLEARANCE LH
93	-	-
94	-	-
95	-	-
96	-	-
97	-	-

Terminal No.	Color of Wire	Signal Name
98	-	-
99	BR/W	AMB SENS GND-FEM
100	SB	AMB SENS SIG-FEM
101	W	PD SENS GND FEM
102	R	PD SENS SIG FEM
103	P	PD SENS PWR FEM
104	-	-
105	V	DTRL RLY
106	-	-

IPDM E/R (INTELLIGENT POWER DISTRIBUTION MODULE ENGINE ROOM)

< ECU DIAGNOSIS >

[HALOGEN TYPE]

Terminal No.	Color of Wire	Signal Name
70	O	MOTRLY
71	-	-
72	R/B	NP SW
73	-	-
74	-	-
75	LG	OIL PRESSURE SW
76	SB	ALT C
77	GR	FPR
78	-	-
79	-	-
80	B/W	STARTER MOTOR

Terminal No.	Color of Wire	Signal Name
47	-	-
48	W	A/C COMP
49	R/G	ING COIL
50	-	-
51	LG	INJECTOR #1
52	Y/G	INJECTOR #2
53	R/W	ENG SOL
54	G/W	ETC
55	W/L	ECM BAT
56	R/Y	O2 SENS #1
57	O	O2 SENS #2
58	Y	AT ECU
59	-	-
60	-	-
61	-	-
62	-	-
63	-	-
64	-	-
65	-	-
66	-	-
67	-	-
68	-	-
69	W/B	SSOFF

Connector No.	F10
Connector Name	IPDM E/R (INTELLIGENT POWER DISTRIBUTION MODULE ENGINE ROOM)
Connector Color	WHITE

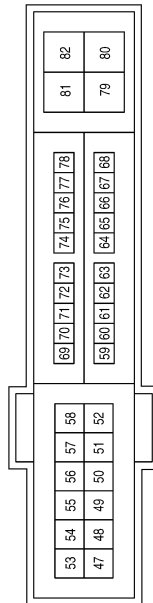

A
B
C
D
E
F
G
H
I
J
K
L
M
N
O
P

EXL

ABMIA1348GB

INFOID:000000005530272

Fail Safe

CAN COMMUNICATION CONTROL

When CAN communication with ECM and BCM is impossible, IPDM E/R performs fail-safe control. After CAN communication recovers normally, it also returns to normal control.

If No CAN Communication Is Available With ECM

IPDM E/R (INTELLIGENT POWER DISTRIBUTION MODULE ENGINE ROOM)

< ECU DIAGNOSIS >

[HALOGEN TYPE]

Control part	Fail-safe in operation
Cooling fan	<ul style="list-style-type: none"> • Signals cooling fans ON when the ignition switch is turned ON • Signals cooling fans OFF when the ignition switch is turned OFF
A/C compressor	A/C relay OFF
Generator	Outputs the power generation command signal (PWM signal) 0%

If No CAN Communication Is Available With BCM

Control part	Fail-safe in operation
Headlamp	<ul style="list-style-type: none"> • Turns ON the headlamp low relay when the ignition switch is turned ON • Turns OFF the headlamp low relay when the ignition switch is turned OFF • Headlamp high relay OFF
<ul style="list-style-type: none"> • Parking lamps • License plate lamps • Illumination • Tail lamps 	<ul style="list-style-type: none"> • Turns ON the tail lamp relay when the ignition switch is turned ON • Turns OFF the tail lamp relay when the ignition switch is turned OFF
Front wiper	<ul style="list-style-type: none"> • The status just before activation of fail-safe control is maintained until the ignition switch is turned OFF while the front wiper is operating at LO or HI speed. • The wiper is operated at LO speed until the ignition switch is turned OFF if the fail-safe control is activated while the front wiper is set in the INT mode and the front wiper motor is operating.
Front fog lamps (if equipped)	Front fog lamp relay OFF
Horn	Horn OFF
Ignition relay	The status just before activation of fail-safe is maintained.
Starter motor	Starter control relay OFF
Electronic steering column lock ¹	Steering lock relay OFF

1: Early production

IGNITION RELAY MALFUNCTION DETECTION FUNCTION

- IPDM E/R monitors the voltage at the contact circuit and excitation coil circuit of the ignition relay inside it.
- IPDM E/R judges the ignition relay error if the voltage differs between the contact circuit and the excitation coil circuit.
- If the ignition relay cannot turn OFF due to contact seizure, it activates the tail lamp relay for 10 minutes to alert the user to the ignition relay malfunction when the ignition switch is turned OFF.

DTC	Ignition switch	Ignition relay	Tail lamp relay
—	ON	ON	—
—	OFF	OFF	—
B2098: IGN RELAY ON	OFF	ON	ON (10 minutes)
B2099: IGN RELAY OFF	ON	OFF	—

NOTE:

The tail lamp turns OFF when the ignition switch is turned ON.

FRONT WIPER CONTROL

IPDM E/R detects front wiper stop position by a front wiper auto stop signal.

When a front wiper auto stop signal is in the conditions listed below, IPDM E/R stops power supply to wiper after repeating a front wiper 10 second activation and 20 second stop five times.

Ignition switch	Front wiper switch	Auto stop signal
ON	OFF	Front wiper stop position signal cannot be input 10 seconds.
	ON	The signal does not change for 10 seconds.

NOTE:

IPDM E/R (INTELLIGENT POWER DISTRIBUTION MODULE ENGINE ROOM)

< ECU DIAGNOSIS >

[HALOGEN TYPE]

This operation status can be confirmed on the IPDM E/R “Data Monitor” that displays “BLOCK” for the item “WIP PROT” while the wiper is stopped.

STARTER MOTOR PROTECTION FUNCTION

IPDM E/R turns OFF the starter control relay to protect the starter motor when the starter control relay remains active for 90 seconds.

DTC Index

INFOID:000000005530273

CONSULT-III display	Fail-safe	TIME ^{NOTE}		Refer to
No DTC is detected. further testing may be required.	—	—	—	—
U1000: CAN COMM CIRCUIT	×	CRNT	1 – 39	PCS-19
B2098: IGN RELAY ON	×	CRNT	1 – 39	PCS-20
B2099: IGN RELAY OFF	—	CRNT	1 – 39	PCS-21
B2108: STRG LCK RELAY ON	—	CRNT	1 – 39	SEC-92
B2109: STRG LCK RELAY OFF	—	CRNT	1 – 39	SEC-93
B210A: STRG LCK STATE SW	—	CRNT	1 – 39	SEC-94
B210B: START CONT RLY ON	—	CRNT	1 – 39	SEC-98
B210C: START CONT RLY OFF	—	CRNT	1 – 39	SEC-99
B210D: STARTER RELAY ON	—	CRNT	1 – 39	SEC-100
B210E: STARTER RELAY OFF	—	CRNT	1 – 39	SEC-101
B210F: INTRLCK/PNP SW ON	—	CRNT	1 – 39	SEC-103
B2110: INTRLCK/PNP SW OFF	—	CRNT	1 – 39	SEC-105

NOTE:

The details of TIME display are as follows.

- CRNT: The malfunctions that are detected now
- 1 - 39: The number is indicated when it is normal at present and a malfunction was detected in the past. It increases like 0 → 1 → 2 ... 38 → 39 after returning to the normal condition whenever IGN OFF → ON. It is fixed to 39 until the self-diagnosis results are erased if it is over 39. It returns to 0 when a malfunction is detected again in the process.

EXL

EXTERIOR LIGHTING SYSTEM SYMPTOMS

< SYMPTOM DIAGNOSIS >

[HALOGEN TYPE]

SYMPTOM DIAGNOSIS

EXTERIOR LIGHTING SYSTEM SYMPTOMS

Symptom Table

INFOID:000000005461001

CAUTION:

Perform the self-diagnosis with CONSULT-III before the symptom diagnosis. Perform the trouble diagnosis if any DTC is detected.

Symptom		Possible cause	Inspection item
Headlamp does not switch to the high beam.	One side	<ul style="list-style-type: none"> • Fuse • Harness between IPDM E/R and the front combination lamp • Front combination lamp (High beam relay) • IPDM E/R 	Headlamp (HI) circuit. Refer to EXL-211 .
	Both sides	Symptom diagnosis "BOTH SIDE HEADLAMPS DO NOT SWITCH TO HIGH BEAM" Refer to EXL-329 .	
High beam indicator lamp is not turned ON. (Headlamp switches to the high beam.)		<ul style="list-style-type: none"> • Combination meter • BCM 	<ul style="list-style-type: none"> • Combination meter. Data monitor "HI-BEAM IND". • BCM (HEAD LAMP). Active test "HEADLAMP".
Headlamp does not switch to the low beam.	One side	Front combination lamp (Low beam relay)	—
	Both sides	<ul style="list-style-type: none"> • Combination switch • Harness between the combination switch and BCM • BCM 	Combination switch. Refer to BCS-10 .
		<ul style="list-style-type: none"> • High beam request signal • BCM • IPDM E/R 	IPDM E/R. Data monitor "HL HI REQ".
		IPDM E/R	—
Headlamp does not turn ON.	One side	<ul style="list-style-type: none"> • Fuse • Bulb • Harness between IPDM E/R and the front combination lamp • Front combination lamp • IPDM E/R 	Headlamp (LO) circuit. Refer to EXL-213 .
	Both sides	Symptom diagnosis "BOTH SIDE HEADLAMPS (LO) ARE NOT TURNED ON" Refer to EXL-330 .	
Headlamp does not turn OFF.	When the ignition switch is turned ON	<ul style="list-style-type: none"> • BCM • Combination switch 	Combination switch. Refer to BCS-10 .
	The ignition switch is turned OFF (After activating the battery saver).	IPDM E/R	—
Headlamp is not turned ON/OFF with the lighting switch AUTO.	<ul style="list-style-type: none"> • Combination switch • Harness between the combination switch and BCM • BCM 		Combination switch. Refer to BCS-10 .
	<ul style="list-style-type: none"> • Optical sensor • Harness between the optical sensor and BCM • BCM 		Optical sensor. Refer to EXL-224 .

EXTERIOR LIGHTING SYSTEM SYMPTOMS

< SYMPTOM DIAGNOSIS >

[HALOGEN TYPE]

Symptom	Possible cause	Inspection item	
Daytime light system does not activate.	<ul style="list-style-type: none"> • Either high beam bulb • Parking brake switch • Combination switch • BCM • IPDM E/R • Daytime light relay • Harness between IPDM E/R and daytime light relay. 	Daytime light system description. Refer to EXL-11 , " System Description ".	
Front fog lamp is not turned ON.	One side	<ul style="list-style-type: none"> • Front fog lamp bulb • Harness between IPDM E/R and the front combination lamp • Front combination lamp • IPDM E/R Front fog lamp circuit. Refer to EXL-215 .	
	Both side	Symptom diagnosis "BOTH SIDE FRONT FOG LAMPS ARE NOT TURNED ON" Refer to EXL-332 .	
Parking lamp is not turned ON.	One side	<ul style="list-style-type: none"> • Fuse • Parking lamp bulb • Harness between IPDM E/R and the front/rear combination lamp • Front/rear combination lamp • IPDM E/R Parking lamp circuit. Refer to EXL-217 .	
	Both sides	Symptom diagnosis "PARKING, LICENSE PLATE AND TAIL LAMPS ARE NOT TURNED ON". Refer to EXL-331 .	
Turn signal lamp does not blink.	Indicator lamp is normal. (The applicable side performs the high flasher activation).	<ul style="list-style-type: none"> • Harness between BCM and each turn signal lamp • Turn signal lamp bulb • Door mirror (if equipped with turn signals in the door mirrors) Turn signal lamp circuit. Refer to EXL-221 .	
Turn signal indicator lamp does not blink.	One side	Combination meter	
	Both sides (Always)	<ul style="list-style-type: none"> • Turn signal indicator lamp signal • Combination meter • BCM 	<ul style="list-style-type: none"> • Combination meter. Data monitor "TURN IND". • BCM (FLASHER). Active test "FLASHER".
	Both sides (Does blink when activating the hazard warning lamp with the ignition switch OFF)	<ul style="list-style-type: none"> • The combination meter power supply and the ground circuit • Combination meter 	Combination meter. Power supply and the ground circuit. Refer to MWI-37 .

A
B
C
D
E
F
G
H
I
J
K
M
N
O
P

EXL

NORMAL OPERATING CONDITION

< SYMPTOM DIAGNOSIS >

[HALOGEN TYPE]

NORMAL OPERATING CONDITION

Description

INFOID:000000005461002

AUTO LIGHT SYSTEM

The auto light system may not turn the headlamp ON/OFF immediately after passing a dark area or a bright area (short tunnel, sky bridge, shadowed area etc.). This is normal.

BOTH SIDE HEADLAMPS DO NOT SWITCH TO HIGH BEAM

< SYMPTOM DIAGNOSIS >

[HALOGEN TYPE]

BOTH SIDE HEADLAMPS DO NOT SWITCH TO HIGH BEAM

Description

INFOID:000000005530285

The headlamps (both sides) do not switch to high beam when the lighting switch is in the HI or PASS setting.

Diagnosis Procedure

INFOID:000000005530286

1.COMBINATION SWITCH INSPECTION

Check the combination switch. Refer to [EXL-195, "System Description"](#).

Is the combination switch normal?

YES >> GO TO 2.

NO >> Repair or replace the malfunctioning part.

2.CHECK HEADLAMP (HI) REQUEST SIGNAL INPUT

 CONSULT-III DATA MONITOR

1. Select "HL HI REQ" of IPDM E/R DATA MONITOR item.
2. While operating the lighting switch, check the monitor status.

Monitor item	Condition		Monitor status
HL HI REQ	Lighting switch (2ND)	HI or PASS	ON
		Except for HI or PASS	OFF

Is the item status normal?

YES >> GO TO 3.

NO >> Replace BCM. Refer to [BCS-87, "Removal and Installation"](#).

3.HEADLAMP (HI) CIRCUIT INSPECTION

Check the headlamp (HI) circuit. Refer to [EXL-211, "Diagnosis Procedure"](#).

Is the headlamp (HI) circuit normal?

YES >> Replace IPDM E/R. Refer to [PCS-41, "Removal and Installation"](#).

NO >> Repair or replace the malfunctioning part.

A
B
C
D
E
F
G
H
I
J
K

EXL

BOTH SIDE HEADLAMPS (LO) ARE NOT TURNED ON

< SYMPTOM DIAGNOSIS >

[HALOGEN TYPE]

BOTH SIDE HEADLAMPS (LO) ARE NOT TURNED ON

Description

INFOID:000000005530287

The headlamps (both sides) do not turn ON in any lighting switch setting.

Diagnosis Procedure

INFOID:000000005530288

1. CHECK COMBINATION SWITCH

Check the combination switch. Refer to [EXL-195, "System Description"](#).

Is the combination switch normal?

YES >> GO TO 2.

NO >> Repair or replace the malfunctioning part.

2. CHECK HEADLAMP (LO) REQUEST SIGNAL INPUT

Ⓟ CONSULT-III DATA MONITOR

1. Select "HL LO REQ" of IPDM E/R DATA MONITOR item.
2. While operating the lighting switch, check the monitor status.

Monitor item	Condition	Monitor status	
HL LO REQ	Lighting switch	2ND	ON
		OFF	OFF

Is the item status normal?

YES >> GO TO 3.

NO >> Replace BCM. Refer to [BCS-87, "Removal and Installation"](#).

3. HEADLAMP (LO) CIRCUIT INSPECTION

Check the headlamp (LO) circuit. Refer to [EXL-213, "Diagnosis Procedure"](#).

Is the headlamp (LO) circuit normal?

YES >> Replace IPDM E/R. Refer to [PCS-41, "Removal and Installation"](#).

NO >> Repair or replace the malfunctioning part.

PARKING, LICENSE PLATE AND TAIL LAMPS ARE NOT TURNED ON

< SYMPTOM DIAGNOSIS >

[HALOGEN TYPE]

PARKING, LICENSE PLATE AND TAIL LAMPS ARE NOT TURNED ON

Description

INFOID:000000005530289

The parking, license plate and tail lamps do not turn ON in with any lighting switch setting.

Diagnosis Procedure

INFOID:000000005530290

1.COMBINATION SWITCH INSPECTION

Check the combination switch. Refer to [EXL-195, "System Description"](#).

Is the combination switch normal?

YES >> GO TO 2.

NO >> Repair or replace the malfunctioning part.

2.CHECK TAIL LAMP RELAY REQUEST SIGNAL INPUT

 CONSULT-III DATA MONITOR

1. Select "TAIL & CLR REQ" of IPDM E/R DATA MONITOR item.
2. While operating the lighting switch, check the monitor status.

Monitor item	Condition	Monitor status	
TAIL & CLR REQ	Lighting switch	1ST	ON
		OFF	OFF

Is the item status normal?

YES >> GO TO 3.

NO >> Replace BCM. Refer to [BCS-87, "Removal and Installation"](#).

3.PARK LAMP CIRCUIT INSPECTION

Check the parking lamp circuit. Refer to [EXL-217, "Diagnosis Procedure"](#).

Is the tail lamp circuit normal?

YES >> Replace IPDM E/R. Refer to [PCS-41, "Removal and Installation"](#).

NO >> Repair or replace the malfunctioning part.

A
B
C
D
E
F
G
H
I
J
K
M
N
O
P

EXL

BOTH SIDE FRONT FOG LAMPS ARE NOT TURNED ON

< SYMPTOM DIAGNOSIS >

[HALOGEN TYPE]

BOTH SIDE FRONT FOG LAMPS ARE NOT TURNED ON

Description

INFOID:000000005530291

The front fog lamps do not turn ON in any setting.

Diagnosis Procedure

INFOID:000000005530292

1.COMBINATION SWITCH INSPECTION

Check the combination switch. Refer to [EXL-195, "System Description"](#).

Is the combination switch normal?

YES >> GO TO 2.

NO >> Repair or replace the malfunctioning part.

2.CHECK FRONT FOG LAMP REQUEST SIGNAL INPUT

ⓅCONSULT-III DATA MONITOR

1. Select "FR FOG REQ" of IPDM E/R DATA MONITOR item.
2. While operating the front fog lamp switch, check the monitor status.

Monitor item	Condition	Monitor status	
FR FOG REQ	Front fog lamp switch (Lighting switch 2ND)	ON	ON
		OFF	OFF

Is the item status normal?

YES >> GO TO 3.

NO >> Replace BCM. Refer to [BCS-87, "Removal and Installation"](#).

3.FRONT FOG LAMP CIRCUIT INSPECTION

Check the front fog lamp circuit. Refer to [EXL-215, "Diagnosis Procedure"](#).

Is the front fog lamp circuit normal?

YES >> Replace IPDM E/R. Refer to [PCS-41, "Removal and Installation"](#).

NO >> Repair or replace the malfunctioning part.

PRECAUTION

PRECAUTIONS

Precaution for Supplemental Restraint System (SRS) "AIR BAG" and "SEAT BELT PRE-TENSIONER"

INFOID:000000005461011

The Supplemental Restraint System such as "AIR BAG" and "SEAT BELT PRE-TENSIONER", used along with a front seat belt, helps to reduce the risk or severity of injury to the driver and front passenger for certain types of collision. This system includes seat belt switch inputs and dual stage front air bag modules. The SRS system uses the seat belt switches to determine the front air bag deployment, and may only deploy one front air bag, depending on the severity of a collision and whether the front occupants are belted or unbelted. Information necessary to service the system safely is included in the SR and SB section of this Service Manual.

WARNING:

- To avoid rendering the SRS inoperative, which could increase the risk of personal injury or death in the event of a collision which would result in air bag inflation, all maintenance must be performed by an authorized NISSAN/INFINITI dealer.
- Improper maintenance, including incorrect removal and installation of the SRS, can lead to personal injury caused by unintentional activation of the system. For removal of Spiral Cable and Air Bag Module, see the SR section.
- Do not use electrical test equipment on any circuit related to the SRS unless instructed to in this Service Manual. SRS wiring harnesses can be identified by yellow and/or orange harnesses or harness connectors.

PRECAUTIONS WHEN USING POWER TOOLS (AIR OR ELECTRIC) AND HAMMERS

WARNING:

- When working near the Airbag Diagnosis Sensor Unit or other Airbag System sensors with the Ignition ON or engine running, DO NOT use air or electric power tools or strike near the sensor(s) with a hammer. Heavy vibration could activate the sensor(s) and deploy the air bag(s), possibly causing serious injury.
- When using air or electric power tools or hammers, always switch the Ignition OFF, disconnect the battery, and wait at least 3 minutes before performing any service.

Precautions Necessary for Steering Wheel Rotation after Battery Disconnect (Early Production, With Electronic Steering Column Lock)

INFOID:000000005885955

NOTE:

- Before removing and installing any control units, first turn the push-button ignition switch to the LOCK position, then disconnect both battery cables.
- After finishing work, confirm that all control unit connectors are connected properly, then re-connect both battery cables.
- Always use CONSULT-III to perform self-diagnosis as a part of each function inspection after finishing work. If a DTC is detected, perform trouble diagnosis according to self-diagnosis results.

This vehicle is equipped with a push-button ignition switch and a steering lock unit.

If the battery is disconnected or discharged, the steering wheel will lock and cannot be turned.

If turning the steering wheel is required with the battery disconnected or discharged, follow the procedure below before starting the repair operation.

OPERATION PROCEDURE

1. Connect both battery cables.

NOTE:

Supply power using jumper cables if battery is discharged.

2. Carry the Intelligent Key or insert it to the key slot and turn the push-button ignition switch to ACC position. (At this time, the steering lock will be released.)
3. Disconnect both battery cables. The steering lock will remain released with both battery cables disconnected and the steering wheel can be turned.
4. Perform the necessary repair operation.

A
B
C
D
E
F
G
H
I
J
K

EXL

M
N
O
P

PRECAUTIONS

< PRECAUTION >

[HALOGEN TYPE]

5. When the repair work is completed, re-connect both battery cables. With the brake pedal released, turn the push-button ignition switch from ACC position to ON position, then to LOCK position. (The steering wheel will lock when the push-button ignition switch is turned to LOCK position.)
6. Perform self-diagnosis check of all control units using CONSULT-III.

General precautions for service operations

INFOID:000000005461013

- Turn the lighting switch OFF before disconnecting and connecting the connector.
- When checking the headlamp on/off operation, check it on vehicle and with the power connected to the vehicle-side connector.
- Leaving the bulb removed from the headlamp housing for a long period of time can deteriorate the performance of the lens and reflector (dirt, clouding). Always prepare a new bulb and have it on hand when replacing the bulb.
- When adjusting the headlamp aiming, turn the aiming adjustment screw only in the tightening direction. (If it is necessary to loosen the screw, first fully loosen the screw, and then turn it in the tightening direction.)

HEADLAMP AIMING ADJUSTMENT

< ON-VEHICLE MAINTENANCE >

[HALOGEN TYPE]

ON-VEHICLE MAINTENANCE

HEADLAMP AIMING ADJUSTMENT

Description

INFOID:000000005461014

PREPARATION BEFORE ADJUSTING

NOTE:

- For details, refer to the regulations in your area.
- Perform aiming adjustment if the vehicle front body has been repaired and/or the front combination lamp assembly has been replaced.

Before performing aiming adjustment, check the following.

- Adjust the tire pressure to specification.
- Position vehicle and screen on level surface.
- Ensure there is no load in vehicle other than the driver (or equivalent weight placed in driver's position).
- Ensure engine coolant and engine oil are filled to correct level and fuel tank is full.
- Confirm spare tire, jack and tools are properly stowed.
- Wipe off dirt on the headlamp.

CAUTION:

Never use organic solvent (thinner, gasoline etc.)

AIMING ADJUSTMENT SCREW

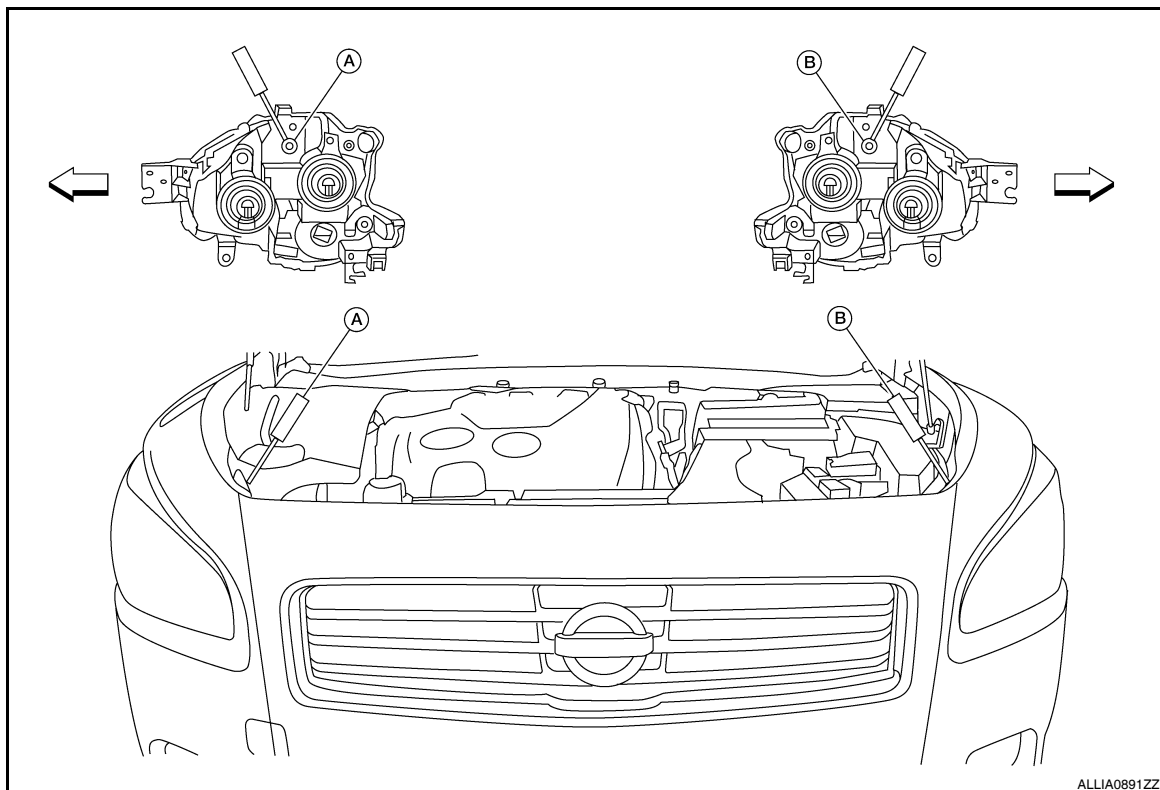

- A. Headlamp RH (UP/DOWN) adjustment screw B. Headlamp LH (UP/DOWN) adjustment screw ⇐ Vehicle center

Adjustment screw		Screw driver rotation	Facing direction
A	Headlamp RH (UP/DOWN)	Clockwise	DOWN
		Counterclockwise	UP
B	Headlamp LH (UP/DOWN)	Clockwise	DOWN
		Counterclockwise	UP

HEADLAMP AIMING ADJUSTMENT

[HALOGEN TYPE]

< ON-VEHICLE MAINTENANCE >

INFOID:000000005461015

Aiming Adjustment Procedure

1. Position the screen.

NOTE:

- Stop the vehicle facing the screen.
- Place the screen on a plain road vertically.

2. Face the screen with the vehicle. Maintain 7.62 m (25 ft) between the headlamp bulb center and the screen.

3. Start the engine. Turn the headlamp (LO) ON.

CAUTION:

Never cover the lens surface with tape, etc. The lens is made of resin.

NOTE:

- Aim each headlamp individually and ensure other headlamp beam pattern is blocked from screen.
- For horizontal aiming, adjust headlamp until beam pattern is at horizontal center point.

Adjustment Using An Adjustment Screen (Light/Dark Borderline)

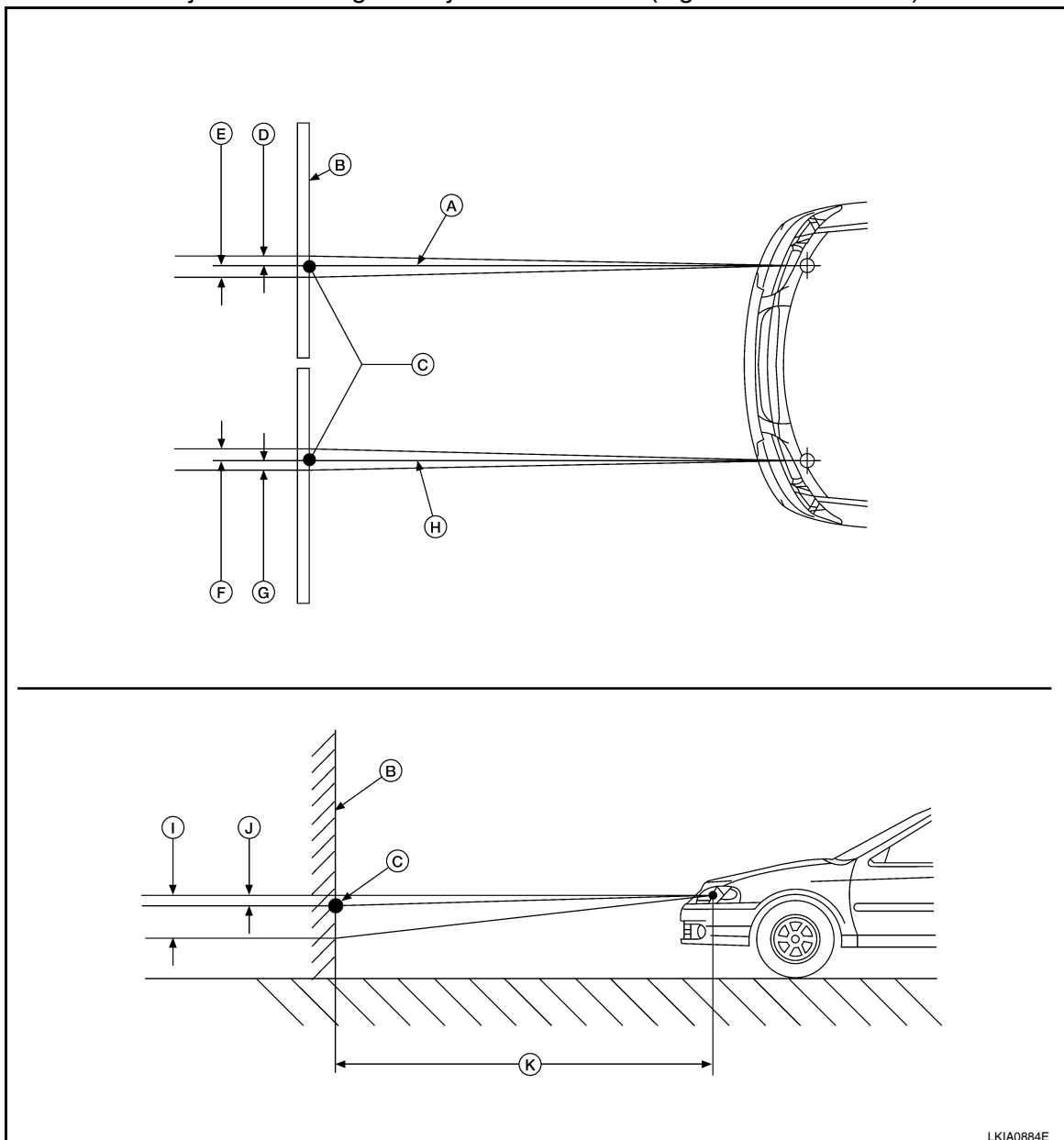

LKIA0884E

A. Headlamp beam (RH)

B. Screen

C. Horizontal/Vertical center point of headlamp

D. 66.5 mm (2.6 in)

E. 66.5 mm (2.6 in)

F. 66.5 mm (2.6 in)

HEADLAMP AIMING ADJUSTMENT

< ON-VEHICLE MAINTENANCE >

[HALOGEN TYPE]

G. 66.5 mm (2.6 in)

H. Headlamp beam (LH)

I. 53.2 mm (2.1 in)

J. 13.3 mm (0.5 in)

K. 7.62 m (25 ft)

A

B

C

D

E

F

G

H

I

J

K

EXL

M

N

O

P

FRONT FOG LAMP AIMING ADJUSTMENT

< ON-VEHICLE MAINTENANCE >

[HALOGEN TYPE]

FRONT FOG LAMP AIMING ADJUSTMENT

Description

INFOID:000000005461016

PREPARATION BEFORE ADJUSTING

NOTE:

For details, refer to the regulations in your area.

Before performing aiming adjustment, check the following.

- Adjust the tire pressure to specification.
- Position vehicle and screen on level surface.
- Ensure there is no load in vehicle other than the driver (or equivalent weight placed in driver's position).
- Ensure engine coolant and engine oil are filled to correct levels and fuel tank is full.
- Confirm spare tire, jack and tools are properly stowed.
- Wipe off dirt on the headlamp.

CAUTION:

Never use organic solvent (thinner, gasoline etc.).

AIMING ADJUSTMENT SCREW

- Turn the aiming adjusting screw for adjustment as shown.

NOTE:

A screwdriver or hexagonal wrench [6 mm (0.24 in)] can be used for adjustment.

- A: Up
- B: Down

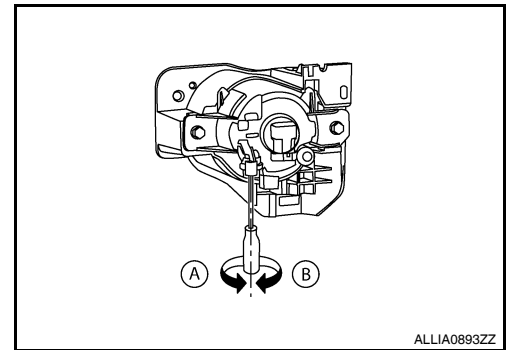

Aiming Adjustment Procedure

INFOID:000000005461017

1. Position the screen.

NOTE:

- Stop the vehicle facing the screen.
- Place the screen on a plain road vertically.

2. Face the screen with the vehicle. Maintain 7.62 m (25.0 ft) between the front fog lamp center and the screen.

3. Start the engine. Turn the front fog lamp ON.

CAUTION:

Never cover the lens surface with tape, etc. The lens is made of resin.

NOTE:

- Aim each fog lamp individually and ensure other fog lamp beam pattern is blocked from screen.

4. Adjust the cutoff line height (A) with the aiming adjustment screw so that the distance (X) between the horizontal center line of front fog lamp (H) and (A) becomes 100 mm (4.0 in).

- Front fog lamp light distribution on the screen is as shown.

- A: Cutoff line
- B: High illuminance area
- H: Horizontal center line of front fog lamp
- V: Vertical center line of front fog lamp
- X: Cutoff line height

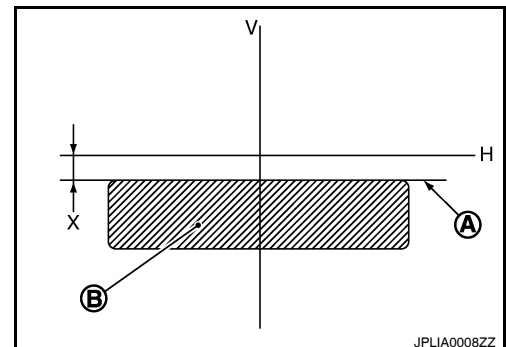

FRONT COMBINATION LAMP

< ON-VEHICLE REPAIR >

[HALOGEN TYPE]

ON-VEHICLE REPAIR

FRONT COMBINATION LAMP

Exploded View

INFOID:000000005461018

REMOVAL

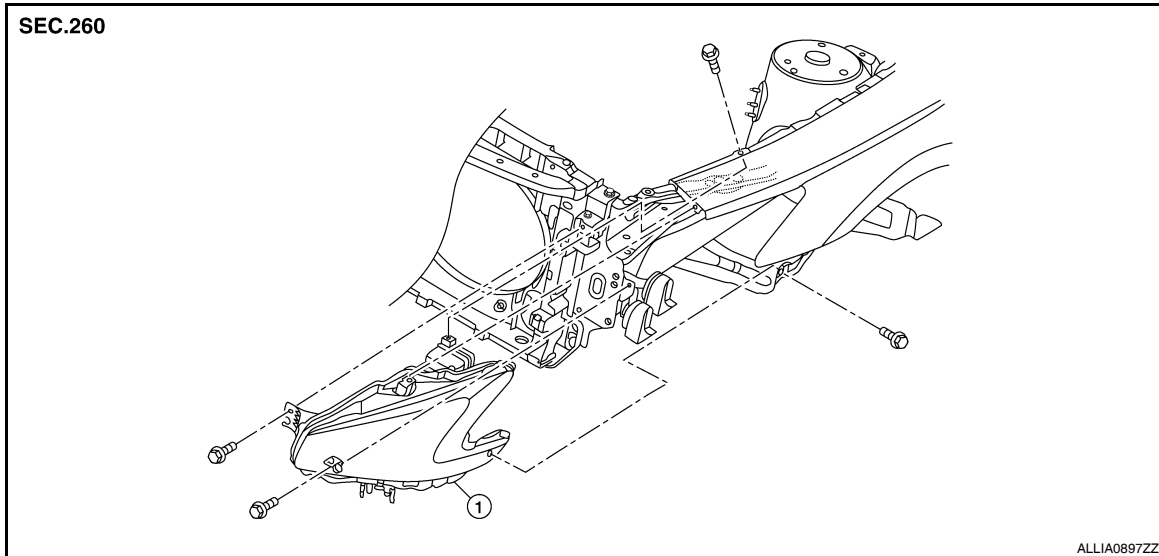

1. Front combination lamp

DISASSEMBLY

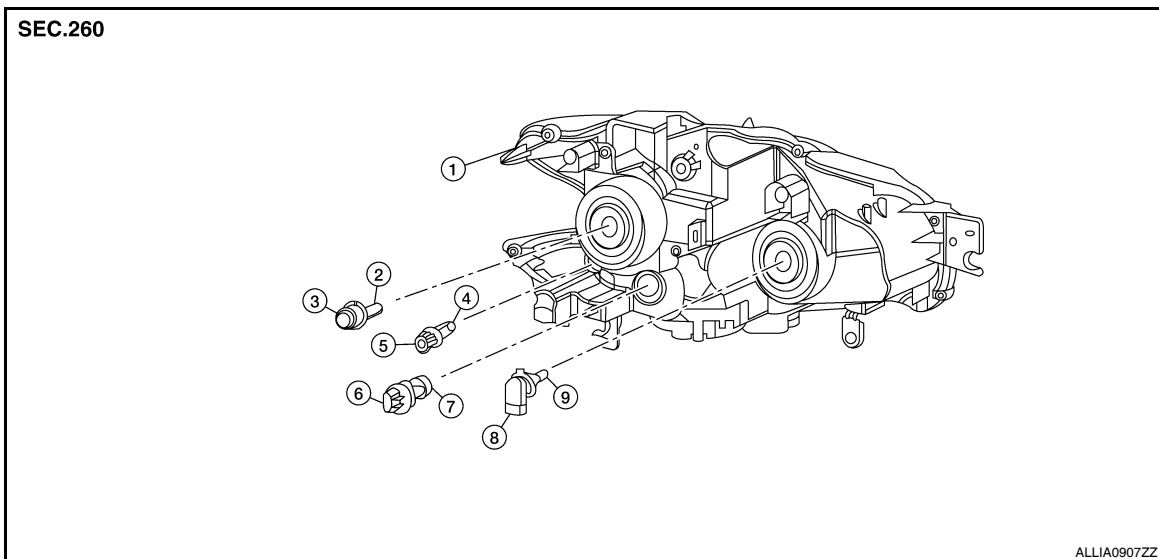

- | | | |
|--------------------------------|------------------------------------|-----------------------------------|
| 1. Front combination lamp | 2. Halogen bulb (low beam) | 3. Halogen bulb socket (low beam) |
| 4. Side marker lamp bulb | 5. Side marker lamp socket | 6. Front turn signal lamp socket |
| 7. Front turn signal lamp bulb | 8. Halogen bulb socket (high beam) | 9. Halogen bulb (high beam) |

Removal and Installation

INFOID:000000005461019

REMOVAL

1. Remove the front bumper fascia. Refer to [EXT-14, "Removal and Installation"](#).
2. Remove the front combination lamp bolts.

A
B
C
D
E
F
G
H
I
J
K
L
M
N
O
P

EXL

FRONT COMBINATION LAMP

[HALOGEN TYPE]

< ON-VEHICLE REPAIR >

3. Remove the harness clips from the front combination lamp assembly.
4. Pull out the front combination lamp toward the front of vehicle.
5. Disconnect the harness connectors before removing the front combination lamp.

INSTALLATION

Installation is in the reverse order of removal.

NOTE:

After installation, perform headlamp aiming adjustment. Refer to [EXL-335. "Description"](#).

Replacement

INFOID:000000005461020

WARNING:

- Never touch bulb by hand while it is lit or right after being turned off.

CAUTION:

- Never touch the glass of bulb directly by hand. Keep grease and other oily matters away from it.
- Never leave bulb out of lamp reflector for a long time because dust, moisture, smoke, etc., may affect the performance of lamp. When replacing bulb, be sure to replace it with new one.

HALOGEN BULB (LOW BEAM)

1. Remove the front combination lamp. Refer to [EXL-339. "Removal and Installation"](#).
2. Rotate the bulb socket counterclockwise and unlock it.
3. Remove the bulb from the bulb socket

HALOGEN BULB (HIGH BEAM)

1. Remove the front combination lamp. Refer to [EXL-339. "Removal and Installation"](#).
2. Rotate the bulb socket counterclockwise and unlock it.
3. Remove the bulb from the bulb socket.

FRONT TURN SIGNAL LAMP BULB

1. Remove the front combination lamp. Refer to [EXL-339. "Removal and Installation"](#).
2. Rotate the bulb socket counterclockwise and unlock it.
3. Remove the bulb from the bulb socket.

FRONT SIDE MARKER LAMP BULB

1. Remove the front combination lamp. Refer to [EXL-339. "Removal and Installation"](#).
2. Rotate the bulb socket counterclockwise and unlock it.
3. Remove the bulb from the bulb socket.

Disassembly and Assembly

INFOID:000000005461021

DISASSEMBLY

1. Rotate the halogen bulb socket (low beam) counterclockwise and unlock it.
2. Remove the bulb from halogen bulb socket (low beam).
3. Rotate the halogen bulb socket (high beam) counterclockwise and unlock it.
4. Remove the bulb from halogen bulb socket (high beam).
5. Rotate the front turn signal lamp socket counterclockwise and unlock it.
6. Remove the bulb from front turn signal lamp socket.
7. Rotate the front side marker lamp socket counterclockwise and unlock it.
8. Remove the bulb from front side marker lamp socket.

ASSEMBLY

Assembly is in the reverse order of disassembly.

FRONT FOG LAMP

< ON-VEHICLE REPAIR >

[HALOGEN TYPE]

FRONT FOG LAMP

Exploded View

INFOID:000000005461022

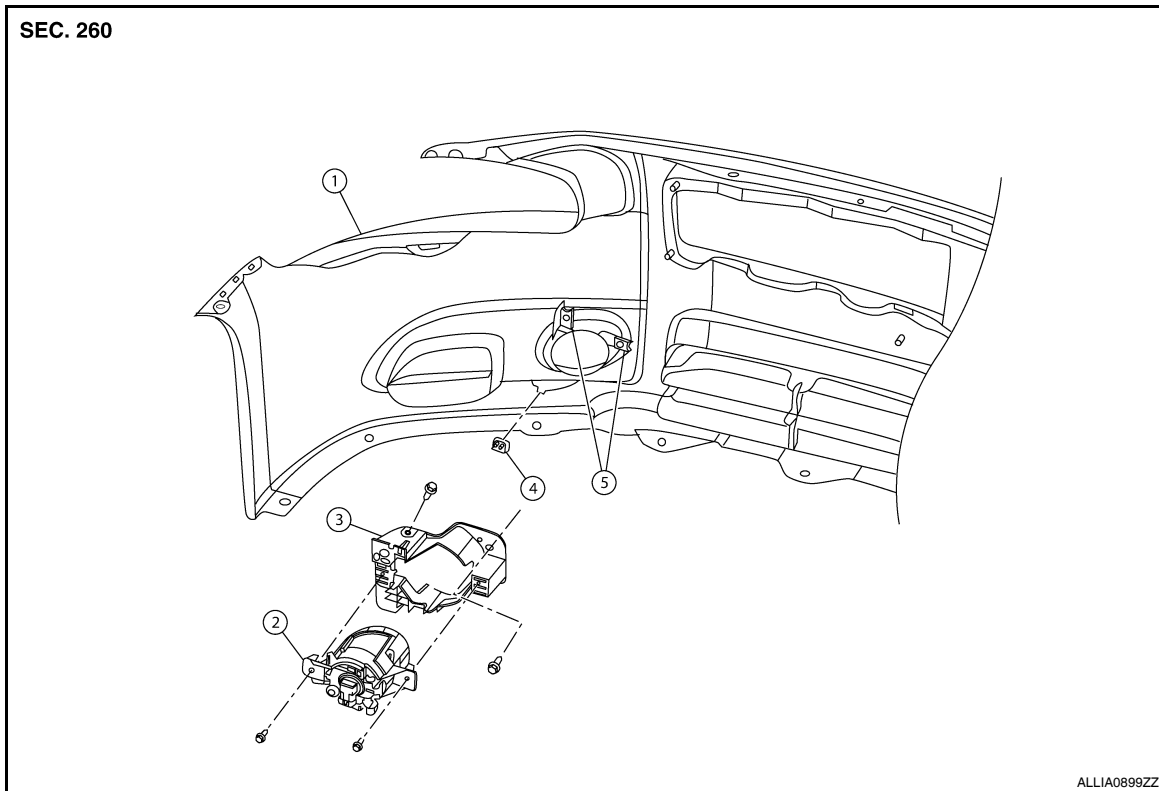

- | | | |
|------------------------|-------------------|---------------------------|
| 1. Front bumper fascia | 2. Front fog lamp | 3. Front fog lamp bracket |
| 4. Clip | 5. Spring nuts | |

Removal and Installation

INFOID:000000005461023

REMOVAL

1. Remove the front bumper fascia. Refer to [EXT-14. "Removal and Installation"](#).
2. Disconnect the front fog lamp harness connector.
3. Remove the front fog lamp bolts.
4. Remove the front fog lamp.

INSTALLATION

Installation is in the reverse order of removal.

NOTE:

After installation, perform front fog lamp aiming adjustment. Refer to [EXL-338. "Description"](#)

Replacement

INFOID:000000005461024

WARNING:

- Never touch bulb by hand while it is lit or right after being turned off.

CAUTION:

- Never touch the glass of bulb directly by hand. Keep grease and other oily matters away from it.
- Never leave bulb out of lamp reflector for a long time because dust, moisture smoke, etc., may affect the performance of lamp. When replacing bulb, be sure to replace it with new one.

FRONT FOG LAMP BULB

1. Remove the front fender protector. Refer to [EXT-20. "Removal and Installation"](#).

FRONT FOG LAMP

[HALOGEN TYPE]

< ON-VEHICLE REPAIR >

2. Disconnect the front fog lamp harness connector (1).
3. Rotate the bulb (2) counterclockwise and unlock it.

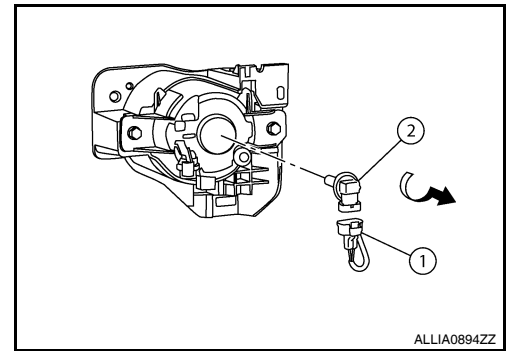

OPTICAL SENSOR

< ON-VEHICLE REPAIR >

[HALOGEN TYPE]

OPTICAL SENSOR

Exploded View

INFOID:000000005461025

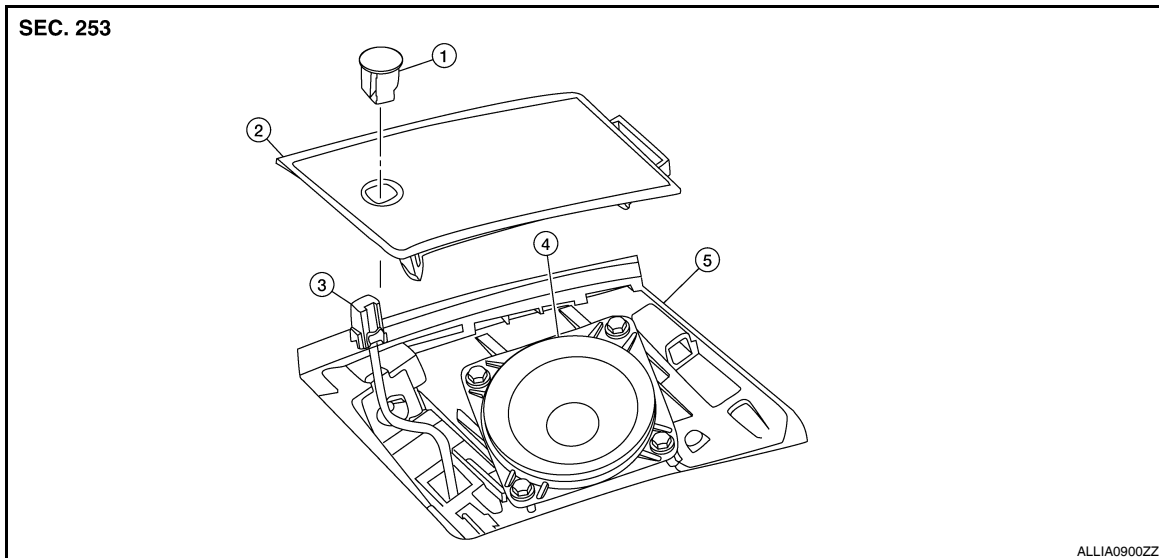

- | | | |
|---------------------|----------------------------|-------------------------------------|
| 1. Optical sensor | 2. LH front speaker grille | 3. Optical sensor harness connector |
| 4. LH front speaker | 5. Instrument panel | |

Removal and Installation

INFOID:000000005461026

REMOVAL

1. Remove the LH front speaker grille.
2. Insert an appropriate tool between the optical sensor and the LH front speaker grille. Pull out the optical sensor upward.
3. Disconnect the optical sensor harness connector and remove the optical sensor.

INSTALLATION

Installation is in the reverse order of removal.

A
B
C
D
E
F
G
H
I
J
K
EXL
M
N
O
P

LIGHTING & TURN SIGNAL SWITCH

< ON-VEHICLE REPAIR >

[HALOGEN TYPE]

LIGHTING & TURN SIGNAL SWITCH

Removal and Installation

INFOID:000000005461027

NOTE:

The lighting and turn signal switch is integral with the combination switch assembly.

REMOVAL

1. Unlock steering wheel (early production, with electronic steering column lock).
2. Disconnect battery.
 - CAUTION:**
 - Before servicing, disconnect both battery terminals and wait at least three minutes.
 - Do not use air tools or electric tools for servicing.
 - After the work is completed, make sure no system malfunction is detected by air bag warning lamp.
 - In case a malfunction is detected by the air bag warning lamp, reset with the self-diagnosis function and delete the memory with CONSULT-III.
 - If a malfunction is still detected after the above operation, perform self-diagnosis to repair malfunctions. Refer to [SRC-12, "SRS Operation Check"](#).
3. Remove steering column covers. Refer to [IP-11, "Exploded View"](#).
4. Rotate steering wheel clockwise to access first combination switch bolt. Remove bolt.
5. Rotate steering wheel counter-clockwise to access second combination switch bolt. Remove bolt, disconnect electrical connectors and combination switch.

INSTALLATION

Installation is in the reverse order of removal.

HAZARD SWITCH

< ON-VEHICLE REPAIR >

[HALOGEN TYPE]

HAZARD SWITCH

Exploded View

INFOID:000000005461028

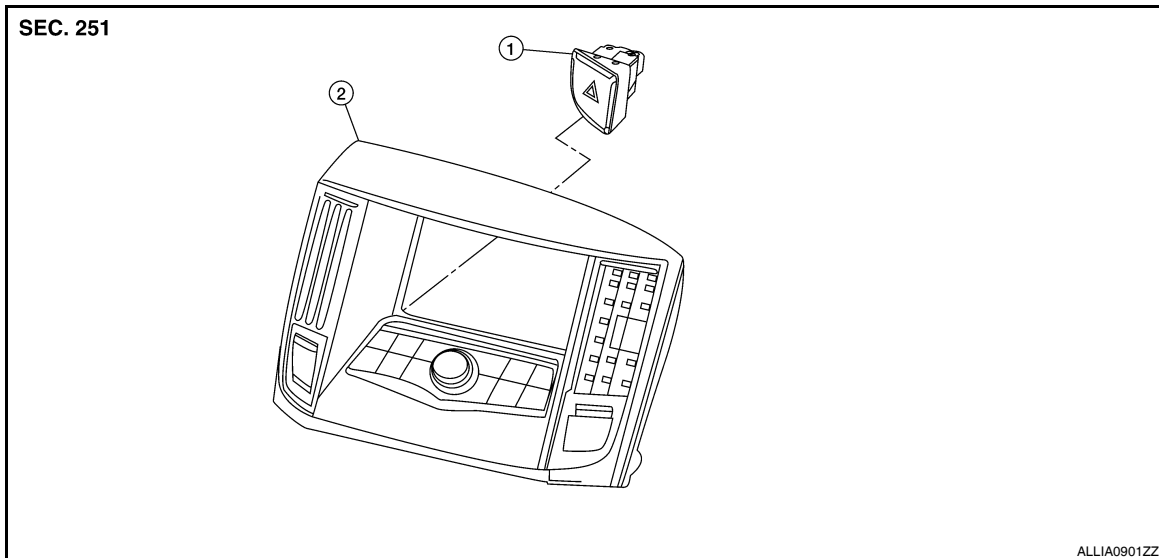

1. Hazard switch

2. Cluster lid D

Removal and Installation

INFOID:000000005461029

REMOVAL

1. Remove cluster lid D. Refer to [IP-11, "Exploded View"](#).
2. Disconnect the hazard switch harness connector.
3. Remove the hazard switch.

INSTALLATION

Installation is in the reverse order of removal.

A
B
C
D
E
F
G
H
I
J
K

EXL

M
N
O
P

REAR COMBINATION LAMP

< ON-VEHICLE REPAIR >

[HALOGEN TYPE]

REAR COMBINATION LAMP

Exploded View

INFOID:000000005461030

REMOVAL

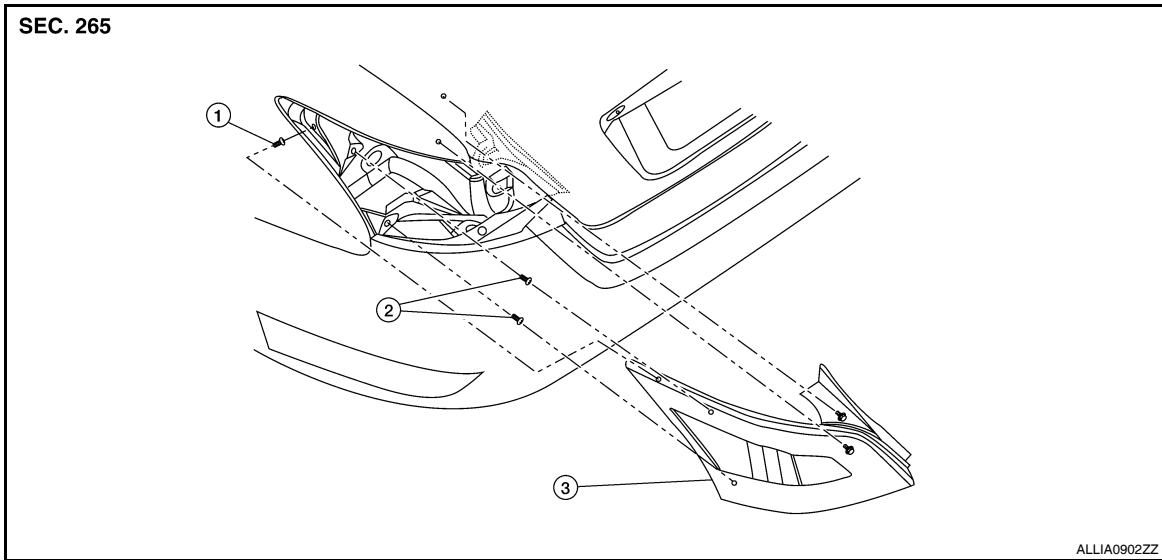

1. Slide clip 2. Grommets 3. Rear combination lamp

DISASSEMBLY

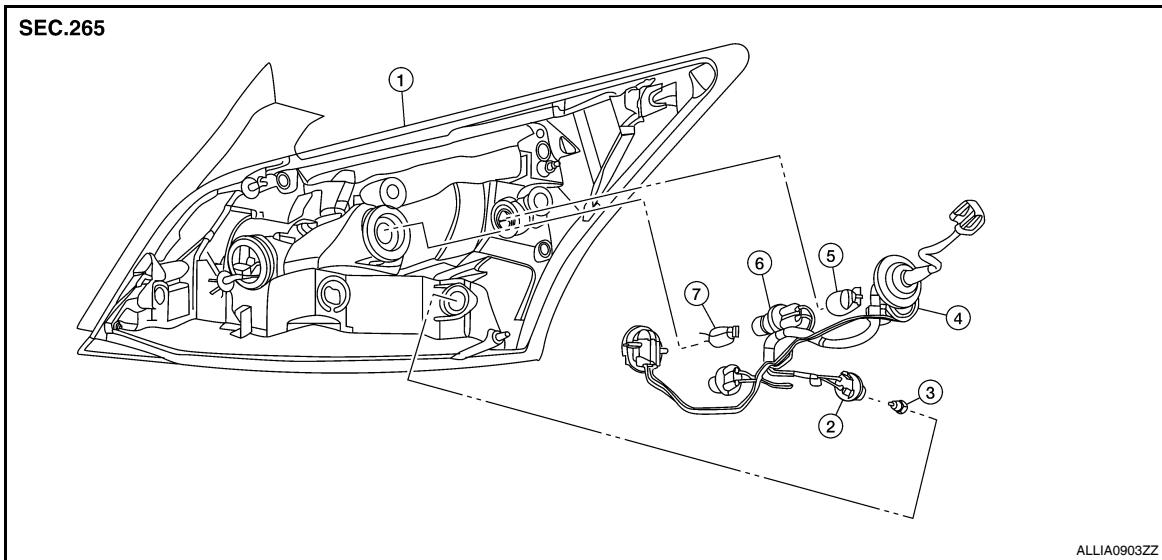

1. Rear combination lamp 2. Rear side marker lamp socket 3. Rear side marker lamp bulb
4. Rear turn signal lamp socket 5. Rear turn signal lamp bulb 6. Back-up lamp socket
7. Back-up lamp bulb

Removal and Installation

INFOID:000000005461031

REMOVAL

1. Remove the trunk side finisher. Refer to [INT-35, "Exploded View"](#).
2. Remove the rear combination lamp nuts.
3. Pull the rear combination lamp toward the rear of the vehicle to remove it.
4. Disconnect the rear combination lamp harness connector.

REAR COMBINATION LAMP

[HALOGEN TYPE]

< ON-VEHICLE REPAIR >

INSTALLATION

Installation is in the reverse order of removal.

Replacement

INFOID:000000005461032

WARNING:

- Never touch bulb by hand while it is lit or right after being turned off.

CAUTION:

- Never touch the glass of bulb directly by hand. Keep grease and other oily matters away from it.
- Never leave bulb out of lamp reflector for a long time because dust, moisture smoke, etc., may affect the performance of lamp. When replacing bulb, be sure to replace it with new one.

STOP/TAIL LAMP

Replacement is integral with rear combination lamp. Refer to [EXL-346, "Exploded View"](#).

REAR SIDE MARKER LAMP BULB

1. Remove the rear combination lamp. Refer to [EXL-346, "Exploded View"](#).
2. Rotate the rear side marker lamp socket counterclockwise and unlock it.
3. Remove the bulb from the rear side marker lamp socket.

REAR TURN SIGNAL LAMP BULB

1. Remove the rear combination lamp. Refer to [EXL-346, "Exploded View"](#).
2. Rotate the rear turn signal lamp socket counterclockwise and unlock it.
3. Remove the bulb from the rear turn signal lamp socket.

BACK-UP LAMP BULB

1. Remove the rear combination lamp. Refer to [EXL-346, "Exploded View"](#).
2. Rotate the back-up lamp socket counterclockwise and unlock it.
3. Remove the bulb from the back-up lamp socket.

A
B
C
D
E
F
G
H
I
J
K
EXL
M
N
O
P

HIGH-MOUNTED STOP LAMP

< ON-VEHICLE REPAIR >

[HALOGEN TYPE]

HIGH-MOUNTED STOP LAMP

Exploded View

INFOID:000000005461033

Models Without Rear Spoiler

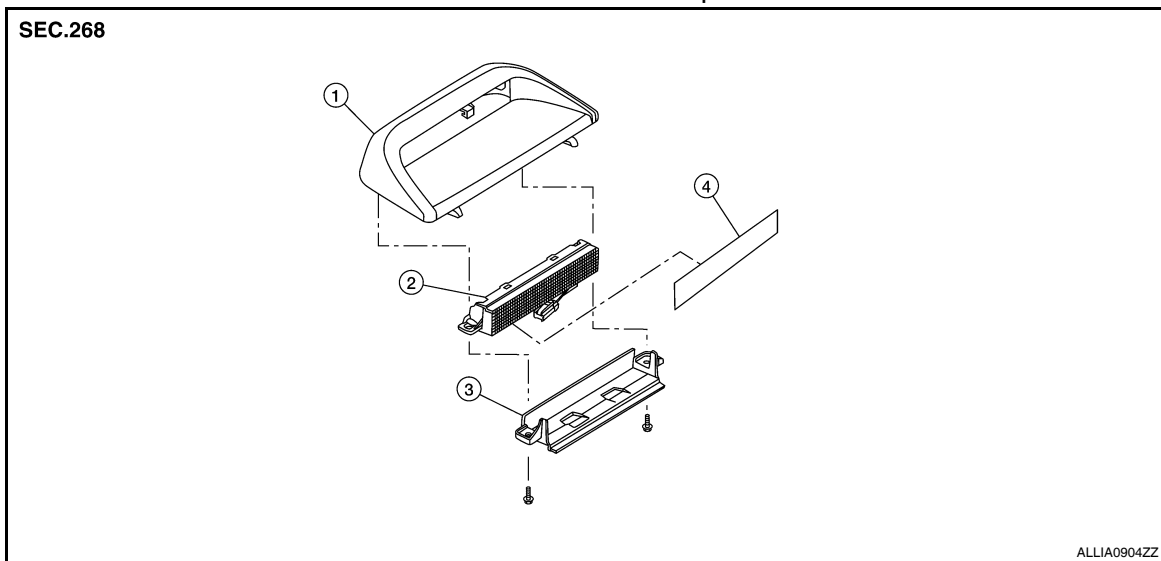

1. High-mounted stop lamp cover
2. High-mounted stop lamp bulb
3. High-mounted stop lamp bracket
4. Lens

Models With Rear Spoiler

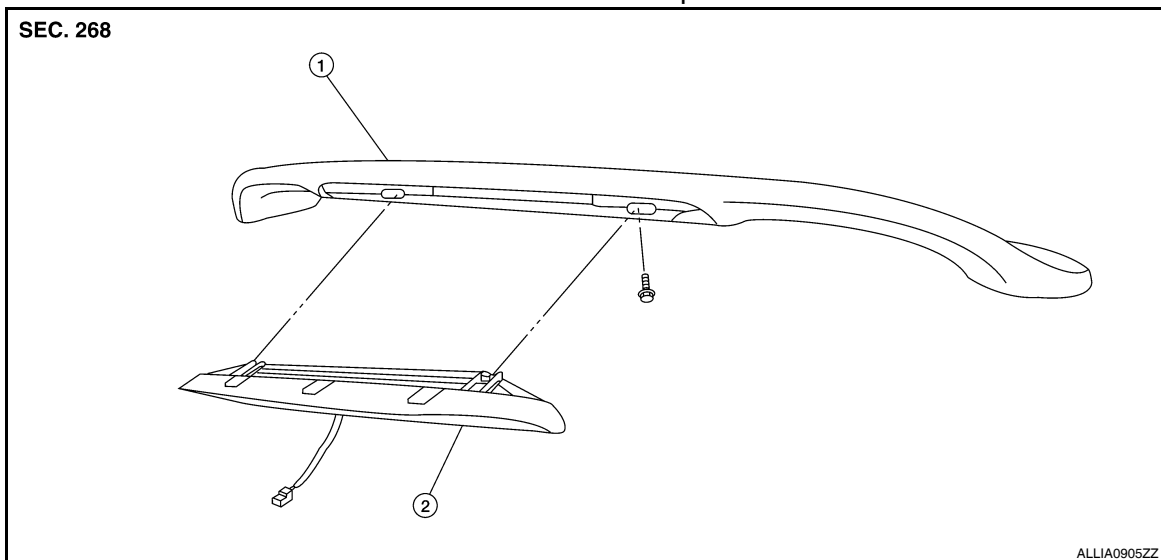

1. Rear spoiler
2. High-mounted stop lamp assembly

Removal and Installation

INFOID:000000005461034

WITHOUT REAR SPOILER

Removal

HIGH-MOUNTED STOP LAMP

< ON-VEHICLE REPAIR >

[HALOGEN TYPE]

1. Slide the high-mounted stop lamp assembly rearward on the parcel shelf to give clearance to the front locking tabs.
2. Lift the front of the high-mounted stop lamp assembly up and slide it forward to give clearance to the rear locking tabs.
3. Disconnect the high-mounted stop lamp connector and remove.

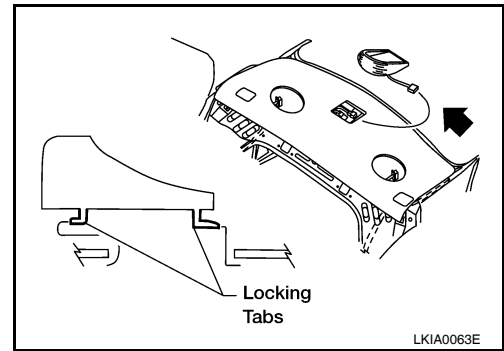

Installation

Installation is in the reverse order of removal.

WITH REAR SPOILER

Removal

1. Remove the high-mounted stop lamp assembly screws.
2. Remove the high-mounted stop lamp assembly from the rear spoiler.

Installation

Installation is in the reverse order of removal.

A
B
C
D
E
F
G
H
I
J
K
EXL
M
N
O
P

LICENSE PLATE LAMP

< ON-VEHICLE REPAIR >

[HALOGEN TYPE]

LICENSE PLATE LAMP

Exploded View

INFOID:000000005461035

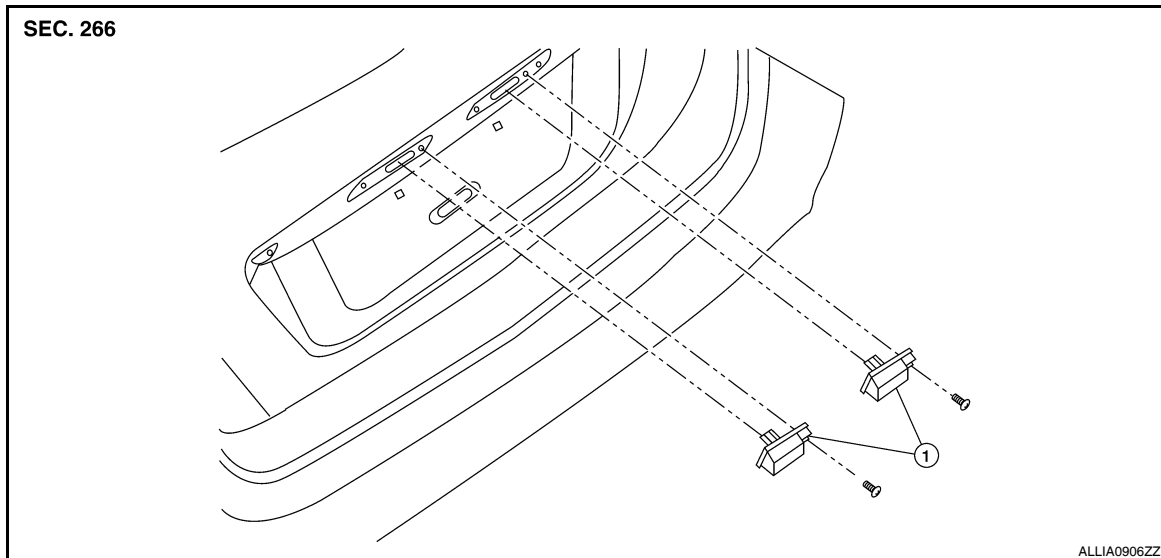

1. License plate lamp

Removal and Installation

INFOID:000000005461036

REMOVAL

1. Remove the license lamp finisher. Refer to [EXT-27, "Removal and Installation"](#).
2. Position trunk lid finisher aside. Refer to [INT-35, "Exploded View"](#).
3. Remove the license plate lamp screw and remove the license plate lamp.

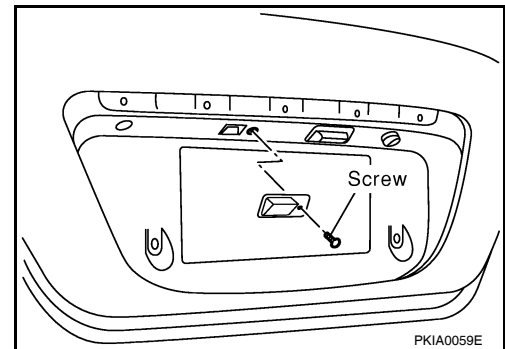

INSTALLATION

Installation is in the reverse order of removal.

Replacement

INFOID:000000005461037

WARNING:

- Never touch bulb by hand while it is lit or right after being turned off.

CAUTION:

- Never touch the glass of bulb directly by hand. Keep grease and other oily matters away from it.
- Never leave bulb out of lamp reflector for a long time because dust, moisture smoke, etc., may affect the performance of lamp. When replacing bulb, be sure to replace it with new one.

LICENSE PLATE LAMP BULB

1. Position trunk lid finisher aside. Refer to [INT-35, "Exploded View"](#).

LICENSE PLATE LAMP

< ON-VEHICLE REPAIR >

[HALOGEN TYPE]

2. Turn the license plate lamp bulb socket counterclockwise and unlock it.
3. Remove the bulb from the license plate lamp bulb socket.

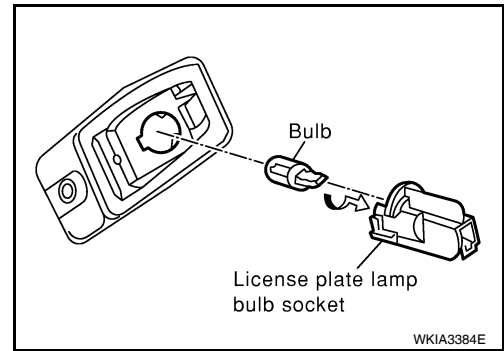

A
B
C
D
E
F
G
H
I
J
K
EXL
M
N
O
P

SERVICE DATA AND SPECIFICATIONS (SDS)

< SERVICE DATA AND SPECIFICATIONS (SDS)

[HALOGEN TYPE]

SERVICE DATA AND SPECIFICATIONS (SDS)

SERVICE DATA AND SPECIFICATIONS (SDS)

Bulb Specifications

INFOID:000000005461038

Item	Type*	Wattage (W)
Front combination lamp	Headlamp (low beam)	H11 (Halogen) 55
	Headlamp (high beam)	9005/HB3 (Halogen) 65
	Park/Turn lamp	3457NAK 8/27
	Front side marker lamp	WY5W 5
Front fog lamp	H11 55	
Rear combination lamp	Stop lamp	LED —
	Tail lamp	LED —
	Rear turn signal lamp	WY21W 21
	Rear side marker lamp	W5W 5
	Back-up lamp	921 18
License plate lamp	168 5	
High-mounted stop lamp	Without rear spoiler	LED —
	With rear spoiler	LED —

*: Always check with the Parts Department for the latest parts information.